

B_04138

Piston Pump

EvoMotion 5-60

Translation of the original operating manual

CE  II 2 G Ex h IIB T3/T4 Gb X

For professional use.

Always observe the information in this manual, particularly the safety instructions and the warning instructions. Store the manual in a safe place.

Edition: 10/2020

TABLE OF CONTENTS

1	About these instructions	5
1.1	Preface	5
1.2	Warnings, Notices and Symbols in these Instructions	5
1.3	General Characters and Symbols	5
1.4	Languages	6
1.5	Abbreviations	6
1.6	Terminology for the Purpose of this Manual	6
2	Correct Use	8
2.1	Device type	8
2.2	Type of Use	8
2.3	For Use in Potentially Explosive Areas	8
2.4	Processible Working Materials	8
2.5	Misuse	9
3	Identification	10
3.1	Explosion Protection Identification	10
3.2	Identification "X"	10
3.3	Type Plate	11
4	Basic Safety Instructions	12
4.1	Safety Instructions for the Operator	12
4.2	Safety Instructions for the Personnel	13
5	Description	18
5.1	Components	18
5.2	Mode of Operation	18
5.3	Protective and Monitoring Equipment	19
5.4	Scope of Delivery	19
5.5	Data	20
5.6	Operating elements	25
6	Assembly and Commissioning	27
6.1	Training of Assembly/Commissioning Personnel	27
6.2	Storage Conditions	27
6.3	Installation Conditions	27
6.4	Transportation	27
6.5	Assembly and Installation	27
6.6	Grounding	29
6.7	Commissioning	31
7	Operation	33
7.1	Training the Operating Personnel	33
7.2	Emergency Stop	33
7.3	Tasks	33
7.4	Pressure Relief / Work Interruption	34
7.5	Basic Flushing	36
7.6	Filling with Working Product	37
8	Cleaning and Maintenance	38
8.1	Cleaning	38
8.2	Maintenance	38

9	Troubleshooting and Rectification	44
10	Repairs	46
10.1	Repair Personnel	46
10.2	Repair Notes	46
10.3	Tools	47
10.4	Cleaning the Parts after Disassembly	47
10.5	Assembly of the Device	47
11	Function Test after Repair Work	48
12	Disposal	49
12.1	Device	49
12.2	Consumable products	49
13	Accessories	50
13.1	Wall Mount and Trolley	51
14	Spare Parts	53
14.1	How Can Spare Parts Be Ordered?	53
14.2	Notes on Using Spare Parts	53
14.3	Overview of the Components	54
14.4	M50 Air Motor with EM Fixing Sensor	55
14.5	M50 Air Motor Without EM Fixing Sensor	58
14.6	Reversing Valve	60
14.7	Fluid section 60	61
15	Declaration of Conformity	63
15.1	EU Declaration of Conformity	63

1 ABOUT THESE INSTRUCTIONS

1.1 PREFACE

The operating manual contains information about safely operating, maintaining, cleaning and repairing the device. The operating manual is part of the device and must be available to the operating and service personnel.





The device may only be operated by trained personnel and in compliance with this operating manual. Operating and service personnel should be instructed according to the safety instructions.

This equipment can be dangerous if it is not operated according to the instructions in this operating manual.

1.2 WARNINGS, NOTICES AND SYMBOLS IN THESE INSTRUCTIONS

Warning instructions in this manual highlight particular dangers to users and to the device and state measures for avoiding the hazard.

These warning instructions fall into the following categories:

	DANGER	Immediate risk of danger. Non-observance will result in death or serious injury.
	WARNING	Potential danger. Non-observance may result in death or serious injury.
	CAUTION	Potentially dangerous situation. Non-observance may result in minor injury.
	NOTICE	Potentially dangerous situation. Non-observance may result in damage to property.
	Info	Provides information about particular characteristics and how to proceed.

Explanation of warning notice:

WARNING

This notice warns you of a danger!

Possible consequences of not observing the warning notice.

- ▶ The measures for preventing the hazard and its consequences.



1.3 GENERAL CHARACTERS AND SYMBOLS

The characters and symbols in this operating manual indicate the following:

✓ Requirement that must be fulfilled before an action can be performed.

1. Step 1 of an action to be performed with several action steps.

- ▶ Second level action step

2. Step 2

⇒ Intermediate result of an action

⇒ Result of a complete action

- ▶ Action to be performed with an action step

1. Numbered list, first level

- Numbered list, second level

- Non-numbered list, first level
 - Non-numbered list, second level

[▶▶ 8] = cross-reference on page

◆ = wearing parts

* = included in service set

● = not part of the standard equipment but available as a special accessory

1.4 LANGUAGES

The operating manual is available in the following languages:

Original operating manual

Language	Order no.
German	2333562

Translation of the original operating manual

Language	Order no.	Language	Order no.
English	2333563	Spanish	2333566
French	2333564	Danish	2383713
Italian	2333565		

Additional languages upon request or at: www.wagner-group.com

1.5 ABBREVIATIONS

Order no.	Order number
ET	Spare part
K	Marking in the spare parts lists
Pos	Position
Stk	Number of pieces
2K	Two components
DH	Double stroke
DN	Nominal diameter
Nr.	Number
PE	polyethylene
PTFE	Polytetrafluorethylene
SSt	Stainless steel
T	PTFE

1.6 TERMINOLOGY FOR THE PURPOSE OF THIS MANUAL

Cleaning

Cleaning	Manual cleaning of devices and device parts with cleaning agent.
Flushing	Internal flushing of paint-wetted parts with flushing agent.
Product pressure generator	Pump or pressure tank.

Personnel qualifications

Trained person	Is instructed in the tasks assigned to him/her, the potential risks associated with improper behavior as well as the necessary protective devices and measures.
Electrically trained person	Is instructed by an electrician about the tasks assigned to him/her, the potential risks associated with improper behavior as well as the necessary protective devices and measures.
Electrician	Can assess the work assigned to him/her and detect possible hazards based on his/her technical training, knowledge and experience in relevant provisions.
Skilled person in accordance with TRBS 1203 (2010/Revision 2012)	A person, who, based on his/her technical training, experience and recent vocational experience, has sufficient technical knowledge in the areas of explosion protection, protection from pressure hazards and electric hazards (if applicable) and is familiar with the relevant and generally accepted rules of technology so that he/she can inspect and assess the status of devices and coating systems based on workplace safety.

2 CORRECT USE

2.1 DEVICE TYPE

Pneumatic piston pump and spray packs:

EvoMotion 5-60

2.2 TYPE OF USE

The device is suitable for processing liquid products like paints and lacquers:

- Non-ignitable products.
- Products in accordance with their classification in explosion class IIB.

WAGNER explicitly prohibits any other use!

The device may only be operated under the following conditions:

- ▶ Use the device only to work with the materials recommended by WAGNER.
- ▶ Do not deactivate safety fixtures.
- ▶ Use only WAGNER original spare parts and accessories.
- ▶ The operating personnel must be trained on the basis of this operating manual.
- ▶ Follow the instructions in the operating manual.

2.3 FOR USE IN POTENTIALLY EXPLOSIVE AREAS

The device can be employed in explosion hazard zones (Zone 1) (see Chapter Identification [▶▶ 10]).



2.4 PROCESSIBLE WORKING MATERIALS

Fluid materials like paints and lacquers.

Application	EvoMotion 20-30
Water-based products	↗
Solvent-based products	↗
Low viscosity (< 40 sec. DIN no. 4)	↗
Medium viscosity (40–60 sec. DIN no. 4)	↘
High viscosity (> 60 sec. DIN no. 4)	↘
UV-sensitive products	→
Shear-sensitive products	↘
Humidity-sensitive products	↘

Signs and definitions: ↗ recommended
 → limited suitability
 ↘ not suitable

⚠ NOTICE

Abrasive working materials and pigments!

Greater wear of product-wetted parts.

- ▶ Use the application-oriented model (flow rate/cycle, product, valves, etc.) as indicated in the Chapter Technical Data.
- ▶ Check if the fluids and solvents being used are compatible with the pump construction materials as indicated in the Chapter Materials of Paint-wetted Parts.
- ▶ Use suitable device combinations (packings, valves etc.)

Wear caused by abrasive working materials is not covered by the warranty.

Typical applications

Application	EvoMotion 20-30
Furniture industry	↗
Kitchen manufacturers	↗
Joinery	↗
Window factories	→
Steel-processing industry	→
Construction of vehicles	↗
Shipbuilding	↘

Signs and definitions: ↗ recommended
 → limited suitability
 ↘ not suitable

2.5 MISUSE

Misuse can lead to physical injury and/or property damage! Special attention must be paid that:

- ▶ No dry coating products, e.g., powder are processed.
- ▶ No food, medicine or cosmetics are processed. It is important to note that the device's materials are not food-safe.

3 IDENTIFICATION

3.1 EXPLOSION PROTECTION IDENTIFICATION

As defined in Directive 2014/34/EU (ATEX), the device is suitable for use in potentially explosive areas.

Device type **EvoMotion 5-60** Piston Pump
Manufacturer Wagner International AG
9450 Altstätten
Switzerland



  II 2 G Ex h IIB T3/T4 Gb X

CE	European Communities
Ex	Symbol for explosion protection
II	Device class II
2	Category 2 (zone 1)
G	Ex-atmosphere gas
Ex	Ignition protection
h	Ignition protection for non-electrical devices
IIB	Explosion group
T3	Maximum surface temperature < 200 °C; 392 °F (without drying protection active)
T4	Maximum surface temperature < 135 °C; 275 °F (with drying protection active)
Gb	Zone 1 high safety level
X	Special notes (see Chapter Identification "X")



3.2 IDENTIFICATION "X"

The maximum surface temperature corresponds to the permissible product temperature. This and the permissible ambient temperature can be found in Chapter Technical data.

Safe Handling of WAGNER Spray Devices

Mechanical sparks can form if the device comes into contact with metal.

In an explosive atmosphere:

- ▶ Knocking or pushing metal against metal is to be avoided.
- ▶ Do not drop the device.

Maximum surface temperature

The maximum surface temperature of the piston pump can be reached if it runs dry.

- Ensure that the piston pump is filled with sufficient working or flushing agent.
- Ensure that the separating agent tank is filled with sufficient separating agent.

Ignition temperature of the coating product

- ▶ Ensure that the ignition temperature of the surrounding gases (pumping product, cleaning agents) is higher than the maximum permitted surface temperature of the device.

Ambient temperature

The permissible ambient temperature range is: 5 °C to 50 °C; 41 °F to 122 °F.

Electrostatic surface spraying

- ▶ Do not spray device parts using electrostatic equipment.



Cleaning

If there are deposits on the surfaces, the device may form electrostatic charges. Flames or sparks can form during discharge.

- ▶ Remove deposits from the surfaces to maintain conductivity.
- ▶ Use only a damp cloth to clean the device.



Air in the pump fluid

Ignitable gas mixtures can form if air enters the pump fluid.

- ▶ Prevent the pump from taking in air and running dry.
- ▶ If air has been taken in, fix the leak. Then, fill slowly and in a controlled manner until the air has escaped.

Air in the pumped fluid can be caused by damaged packings.

- ▶ Avoid operating the pump with damaged packing.
- ▶ Ensure that the separating agent tank is filled with sufficient separating agent.
- ▶ Periodically check that the pump is working smoothly, paying special attention to the presence of air in the pumped fluid.

Filling and emptying

Ignitable gas mixtures can form in the fluid section or product hoses if the pump must be emptied for maintenance and/or repair purposes.

- ▶ Empty and fill the device slowly and in a controlled manner.
- ▶ Avoid potentially explosive atmosphere in the surroundings.

3.3 TYPE PLATE



Example type plate

1	Manufacturer and CE identification	6	Maximum air inlet pressure
2	Pump type	7	Maximum product temperature
3	Maximum product pressure	8	Model year - serial number
4	Pump ratio	9	Read operating manual before use!
5	Flow rate per double stroke		

4 BASIC SAFETY INSTRUCTIONS

4.1 SAFETY INSTRUCTIONS FOR THE OPERATOR

- ▶ Keep this operating manual at hand near the device at all times.
- ▶ Always follow existing regulations concerning occupational safety and accident prevention regulations.



4.1.1 Electrical Devices and Equipment

Danger of electric shock!

Danger to life from electric shock:

- ▶ Place and operate device in accordance with the existing safety requirements with regard to the operating mode and ambient influences.
- ▶ May only be maintained by skilled electricians or under their supervision. With open housings, the mains voltage poses a danger.
- ▶ Operate device in accordance with the safety regulations and electrotechnical regulations.
- ▶ Do not disconnect any plug connections during operation.
- ▶ Label plug connections with the warning "Do not disconnect when energized".
- ▶ Must be repaired immediately in the event of problems.
- ▶ Decommission if device poses a danger or is damaged.
- ▶ Must be de-energized before work is commenced.
 - ▶ Secure the device against being switched back on without authorization.
 - ▶ Inform personnel about planned work.
 - ▶ Observe electrical safety regulations.
- ▶ Ground all devices to a common grounding point.
- ▶ Only operate the device with a properly installed socket with a protective ground wire connection.
- ▶ Keep liquids away from electrical devices.



4.1.2 A Safe Work Environment

Danger due to dangerous fluids or vapors!

Severe or fatal injuries due to explosion danger or inhalation, swallowing or contact with the skin or eyes.

- ▶ Ensure that the floor in the working area is static dissipative in accordance with EN 61340-4-1 (resistance must not exceed 100 M Ω).
- ▶ Paint mist extraction systems/ventilation systems must be fitted on site according to local regulations.
- ▶ Make sure that the ground connection and potential equalization of all system parts are reliable and continuous and can withstand the expected stress (e.g., mechanical stress, corrosion).
- ▶ Ensure that product hoses/air hoses adapted to the working pressure are used.
- ▶ Ensure that personal protective equipment is available and is used.



- ▶ Ensure that all persons within the working area wear static dissipative shoes. Footwear must comply with EN 20344. The measured insulation resistance must not exceed 100 MΩ.
- ▶ Ensure that during spraying, persons wear static dissipative gloves. The grounding takes place via the spray gun's handle or its trigger.
- ▶ Protective clothing, including gloves, must comply with EN 1149-5. The measured insulation resistance must not exceed 100 MΩ.
- ▶ Ensure that there are no ignition sources such as naked flames, sparks, glowing wires, or hot surfaces in the vicinity. No smoking.
- ▶ Ensure that the pipe joints, hoses, equipment parts and connections are permanently, technically leak-proof:
 - ▶ Periodic preventative maintenance and service (replacing hoses, checking tightness strength of connections, etc.)
 - ▶ Regular monitoring of leaks and defects via visual inspection and odor testing, e.g., daily before commissioning, at the end of work or weekly.
- ▶ Ensure that maintenance and safety checks are performed regularly.
- ▶ In the event of defects, immediately bring the device or system to a stop and arrange to have repairs carried out immediately.

4.1.3 Personnel Qualifications

Danger due to incorrect use of device!

Risk of death due to untrained personnel.

- ▶ Ensure that the operating personnel has been instructed by the operator in accordance with the operating manual and the operating instructions. The device must only be operated, maintained and repaired by trained personnel. Refer to the operating instructions for information about the required personnel qualifications.

4.2 SAFETY INSTRUCTIONS FOR THE PERSONNEL

- ▶ Always observe the information in this manual, particularly the safety instructions and the warning instructions.
- ▶ Always follow existing regulations concerning occupational safety and accident prevention regulations.



Danger due to high-voltage field!

Danger to life from malfunction of active implants.

- ▶ Persons belonging to a risk group according to EMF guideline 2013/35/EU (e.g., carriers of active implants), must not enter the high-voltage area.



4.2.1 Personal Safety Equipment

Danger due to dangerous fluids or vapors!

Serious or fatal injuries due to inhalation, swallowing or contact with the skin or eyes.

- ▶ When preparing or working with lacquer and when cleaning the device, follow the working instructions of the manufacturer of the lacquers, solvents and cleaning agents being used.
- ▶ Implement the prescribed safety measures, in particular the wearing of safety glasses, safety clothing and protective gloves as well as the use of protective hand cream.
- ▶ Use a mask or breathing apparatus if necessary.



- ▶ For sufficient health and environmental safety: Operate the device in a spray booth or on a spraying wall with the ventilation (extraction) switched on.
- ▶ Wear suitable protective clothing when working with hot products.

4.2.2 Safe Handling of WAGNER Spray Devices

Danger due to injection of lacquer or flushing agent into the skin!

The spray jet is under pressure and can cause dangerous injuries.

Avoid injection of lacquer or flushing agents:

- ▶ Never point the spray gun at people.
- ▶ Never reach into the spray jet.
- ▶ Perform the following measures before any work on the device, in the event of work interruptions and malfunctions:
 - ▶ Switch off the energy/compressed air supply
 - ▶ Relieve the pressure from the spray gun and device
 - ▶ Securing the Spray Gun Against Actuation
 - ▶ Disconnect the control unit from the mains
 - ▶ In the event of functional faults, remedy the fault as described in the Troubleshooting chapter
- ▶ If needed, the liquid ejection devices must be checked by experts (e.g., WAGNER service technician) at least every 12 months for their work-safe condition in accordance with DGUV regulation 100-500 Chapter 2.29 and Chapter 2.36.
 - ▶ For shut down devices, the examination can be suspended until the next start-up.



In the event of skin injuries caused by lacquer or flushing agents:

- ▶ Note the lacquer or flushing agent that you have been using.
- ▶ Consult a doctor immediately.

Danger due to recoil forces!

Actuating the trigger can cause strong recoil forces. Thereby, the user can lose his balance and injure himself when falling.

Avoid risk of injury from recoil forces:

- ▶ Ensure that you have firm footing when operating the spray gun.



4.2.3 Grounding the Device

Danger due to electrostatic charge!

Risk of injury, explosion hazard and damage to the device.

Friction, flowing liquids and air or electrostatic coating processes create charges. Flames or sparks can form during discharge. Correct grounding of the entire spraying system prevents electrostatic charges.

- ▶ Ensure that all devices and tanks are grounded before each spraying process.
- ▶ Make sure that the ground and potential equalization of all system parts are performed reliably and continuously and can withstand the expected stress (e.g., mechanical stress, corrosion).
- ▶ Ground the work pieces to be coated.
- ▶ Ensure that all persons inside the working area are grounded, e.g., that they are wearing static dissipative shoes.



- ▶ Wear static dissipative gloves when spraying. The grounding takes place via the spray gun's handle or its trigger.

4.2.4 Product Hoses

Danger due to bursting of product hose!

The product hose is under pressure and may cause dangerous injuries.

- ▶ Ensure that the hose material is chemically resistant to the sprayed products and the flushing agents used.
- ▶ Ensure that the product hoses and the fittings are suitable for the pressure generated.
- ▶ Ensure that the following information can be seen on the high-pressure hose:
 - ▶ Manufacturer
 - ▶ permissible operating pressure
 - ▶ Date of manufacture
- ▶ Make sure that the hoses are laid only in suitable places. Hoses should not be laid in the following places under any circumstances:
 - ▶ in high traffic areas
 - ▶ on sharp edges
 - ▶ on moving parts
 - ▶ on hot surfaces
- ▶ Ensure that the hoses are never run over by vehicles (e.g., fork lifts), or that the hoses are never put under pressure from the outside in any other way.
- ▶ Ensure that the hoses are never kinked. Observe maximum bending radii.
- ▶ Ensure that no work is ever performed with a damaged hose.
- ▶ Make sure that the hoses are never used to pull or move the device.
- ▶ The electrical resistance of the product hose, measured at both valves, must be less than 1 MΩ.
- ▶ Suction hoses may not be subjected to pressure.



Several liquids have a high expansion coefficient. In some cases, their volume can rise with consequent damage to pipes, fittings, etc. and cause fluid leakage.

When the pump sucks liquid from a closed tank, ensure that air or a suitable gas can enter the tank. In this way a negative pressure is avoided. The vacuum could implode the tank (squeeze) and can cause it to break. The tank would leak and the liquid would flow out.

The pressure created by the pump can be a multiple of the input air pressure.

4.2.5 Cleaning and Flushing

Danger due to cleaning and flushing!

Explosion hazard and damage to the device.

- ▶ Non-ignitable cleaning agents and flushing agents should preferably be used.
- ▶ When carrying out cleaning work with flammable cleaning agents, make sure that all equipment and resources (e.g., collection tank, funnel, transport cart) are conductive or static dissipative and grounded.
- ▶ Observe the specifications of the lacquer manufacturer.
- ▶ Ensure that the flash point of the cleaning agent is at least 15 K above the ambient temperature or that cleaning is undertaken at a cleaning station with technical ventilation.



- ▶ Never use chloride or halogenated solvents (such as trichloroethane and methylene chloride) with devices containing aluminium or galvanized/zinc-plated parts. They may react chemically thus producing an explosion danger.
- ▶ Take measures for workplace safety.
- ▶ It should be noted that when the device is put into operation or emptied: depending on the coating product used, depending on the rinsing agent (solvent) used, there may briefly be a mixture inside the pipes and equipment which can ignite.
- ▶ Only use electrically conductive tanks for cleaning and flushing agents.
- ▶ The tanks must be grounded.

An explosive gas/air mixture forms in closed tanks.

- ▶ Never spray into a closed tank when using solvents for flushing.

External Cleaning

When cleaning the exterior of the device or its parts, also observe the following:

- ▶ Relieve the pressure from the device.
- ▶ De-energize the device electrically.
- ▶ Disconnect the pneumatic supply line.
- ▶ Use only moistened cloths and brushes. Never use abrasive agents or hard objects and never spray cleaning agents with a gun. Cleaning the device must not damage it in any way.
- ▶ Ensure that no electric component is cleaned with or immersed into solvent.

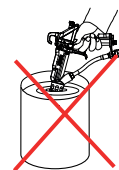

4.2.6 Touching Hot Surfaces

Danger due to hot surfaces because of hot coating products!

Risk of burn injuries

- ▶ Only touch hot surfaces if you are wearing protective gloves.
- ▶ When operating the device with a coating product with a temperature of $> 43\text{ }^{\circ}\text{C}$; $109\text{ }^{\circ}\text{F}$, apply a warning label to the device that says "Warning - Hot Surface."



Instruction label: Order no. 9998910

Protection label: Order no. 9998911

Info

Order the two labels together.



4.2.7 Maintenance and Repair

Danger due to improper maintenance and repair!

Danger to life and equipment damage.

- ▶ Only a WAGNER service center or a suitably trained person may carry out repairs and replace parts.
- ▶ Repair or replacement of devices or parts of devices are only allowed to be performed outside the hazard area by qualified personnel.
- ▶ Use only WAGNER original spare parts and accessories.
- ▶ Do not change or modify the device; if change is necessary, contact WAGNER.
- ▶ Only repair and replace parts that are listed in the accessories and spare parts chapter and that are assigned to the device.

- ▶ Do not use any defective components.
- ▶ Before all work on the device and in the event of work interruptions:
 - ▶ Relieve the pressure from the spray gun, product hoses and all devices.
 - ▶ Secure the spray gun against actuation.
 - ▶ Switch off the energy and compressed air supply.
 - ▶ Disconnect the control unit from the mains.
- ▶ Observe the operating and service manual for all work.

4.2.8 Protective and Monitoring Equipment

Danger due to removal of protective and monitoring equipment!

Danger to life and equipment damage.

- ▶ Protective and monitoring equipment must not be removed, modified or rendered unusable.
- ▶ Regularly check for perfect functioning.
- ▶ If defects are detected on protective and monitoring equipment, the system must not be operated until these defects are remedied.

5 DESCRIPTION

5.1 COMPONENTS

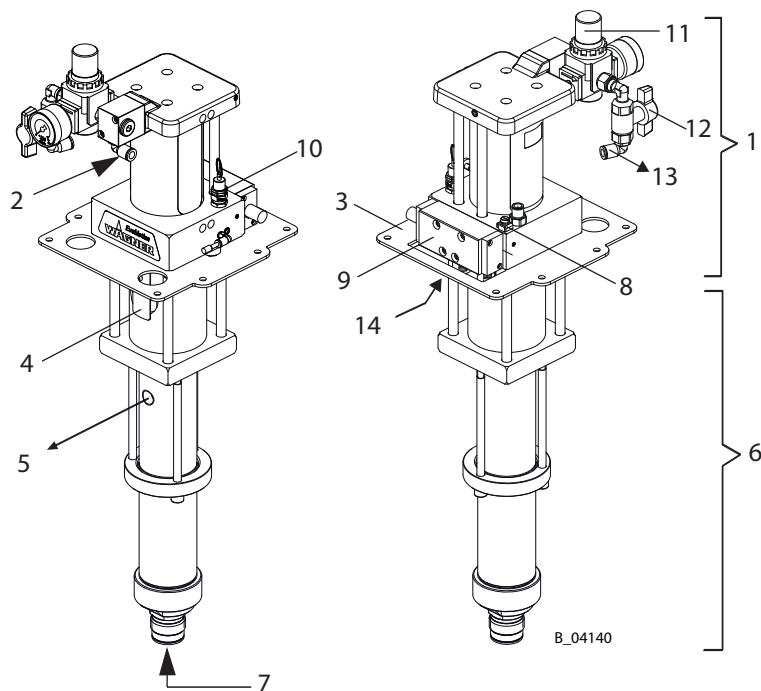

1	Air motor	8	Grounding connection
2	Air input	9	Reversing Valve
3	Mounting flange	10	Safety valve (air motor)
4	Separating agent container	11	Air pressure regulator
5	Product output	12	Ball valve
6	Fluid section	13	Air outlet to the reversing valve
7	Product input	14	Air inlet to the reversing valve

5.2 MODE OF OPERATION

The piston pump is driven with compressed air (2). This compressed air moves the air piston up and down in the air motor (1) and it also moves the the associated pump piston up and down in the fluid section (6). At the end of each stroke, the compressed air flow is redirected by a reversing valve (9). The working product is sucked up during the upwards stroke and, at the same time, is conveyed towards the pressure outlet (5) in both stroke directions.

5.2.1 Air motor

The air motor (1) with its pneumatic reverse (9) does not require pneumatic oil. The compressed air is fed to the motor via the air pressure regulator (11) and the ball valve (12). The air motor is fitted with a safety valve (10) in accordance with Chapter Protective and Monitoring Equipment [>> 19]. The safety valve has been set and sealed at the factory.

5.2.2 Fluid section

The fluid section (6) has been designed as a piston pump with exchangeable ball valves. The pump piston runs in two fixed packings which are self-adjusting by means of a pressure spring, thus resulting in a long service life. Between the air motor and the fluid section there is a separating agent cup (4) for holding the separating agent.

5.3 PROTECTIVE AND MONITORING EQUIPMENT

Safety valve

WARNING

Overpressure!

Danger to life from bursting device components.

- ▶ Never change the safety valve setting.



The air motor is fitted with a safety valve. The safety valve (5) has been factory adjusted so as to ensure that if pressure exceeds the permitted operating pressure, the valve, which is held with a spring, automatically opens and releases the excess pressure. As well as handling pressure limits, the valve is also used as a pressure relief valve for the air motor.

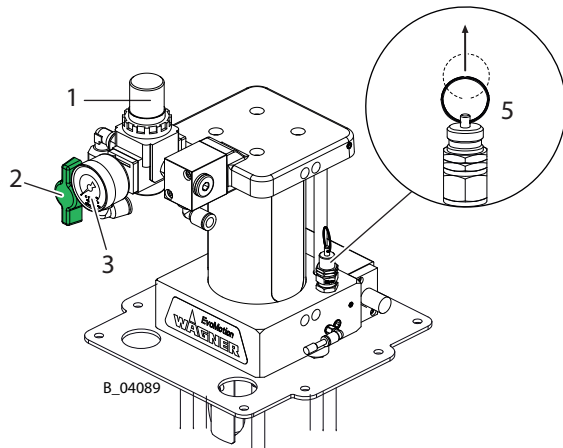

Process for manually relieving pressure

1. Close ball valve (2).
2. Pull the ring on the safety valve (5) and hold it until the pressure in the air motor has been equalized.

5.4 SCOPE OF DELIVERY

Piston pump consisting of:

-	Fluid section
-	Air motor
-	Connection elements
-	Air pressure regulator for air motor

The standard equipment includes:

Stk	Order no.	Designation
1	9992504	Separating agent 250 ml
1	2322562	Operating manual, in German
1	See Chapter EU Declaration of Conformity [▶▶ 63]	Declaration of Conformity
1	See Chapter Languages [▶▶ 6]	Operating manual in the local language

The delivery note shows the exact scope of delivery. Accessories: see Chapter Accessories [▶▶ 50].

5.5 DATA

5.5.1 Materials of Paint-wetted Parts

Paint-wetted part	Product
Pump housing	Stainless steel
Piston	Stainless steel
Valve balls	Stainless steel
Valve seats	Stainless steel
Static seals	PTFE
Packings	PE / T

PE = Polyethylene UHMW

T = Polytetrafluorethylene (PTFE)

Positions of the individual parts: See Chapter Spare Parts [▶▶ 53].

5.5.2 Recommended Packings

WAGNER packings for this device:

Code	Product	Color
PE	Ultra high molecular weight polyethylene	transparent
T	PTFE	white

Each product has the following properties, which influence the packings:

Designation	PE	T
Mechanical stability	good	poor
Friction coefficient	good	very good
Sealing force	good	good
Chemical resistance	very good	very good
Temperature resistance	very good	poor

5.5.3 Technical Data

Description	Units	Evo Motion 20-30
Pump ratio		5:1
Volume flow per double stroke (DH)	cm ³ / cc	60
Maximum operating pressure	MPa bar psi	3.5 35 508
Maximum possible strokes in operation	DH/min	60
Maximum recommended strokes per minute in continuous operation	DH/min	40
Minimum/maximum air inlet pressure	MPa bar psi	0.2–0.8 2–8 28–116
Compressed air quality: free from oil and water	Quality standard	7.5.4 according to ISO 8573.1, 2010
		7: Particle concentration 5–10 mg/m ³
		5: Humidity: pressure dew point ≤ 7 °C
		4: Oil content ≤ 5 mg/m ³
Air inlet diameter (internal thread)	mm; inch	8.0; 0.31
Minimum diameter of the compressed air supply line	mm; inch	9.0; 0.35
Air consumption at 0.6 MPa; 6 bar; 87 psi per double stroke	nl; scf	2.4; 0.09
Air motor piston diameter	mm; inch	50; 1.97
Air motor piston stroke	mm; inch	68; 2.68
Sound pressure level at maximum permissible air pressure*	dB(A)	65.1
Sound pressure level at 0.6 MPa; 6 bar; 87 psi air pressure*	dB(A)	62.9
Sound pressure level at 0.4 MPa; 4 bar; 58 psi air pressure*	dB(A)	61.0
Product input (outside thread)	mm	M36×2
Product output (inside thread)	inch	G 3/8"
Weight	kg; lb	13; 28.7
Product pH value	pH	3.5–9
Maximum product pressure at pump inlet	MPa bar psi	2 20 290
Product temperature	°C	5–80
	°F	41–176
Ambient temperature - Assembly and operation	°C	5–50
	°F	41–122

Description	Units	Evo Motion 20-30
Ambient temperature - Storage	°C	-20–60
	°F	-4–140
Relative humidity	%	10–95 (without condensation)
Allowable inclination for operation	∠°	± 10

* Measured A-rated emission sound pressure level at distance of 1 m, LpA1m in accordance with DIN EN 14462: 2015. Reference measurements have been made by Suva (Swiss National Accident Insurance Fund).

 **WARNING**

Exhaust air containing oil!

Risk of poisoning if inhaled.

- ▶ Provide compressed air free from oil and water.



5.5.4 Dimensions and Connections

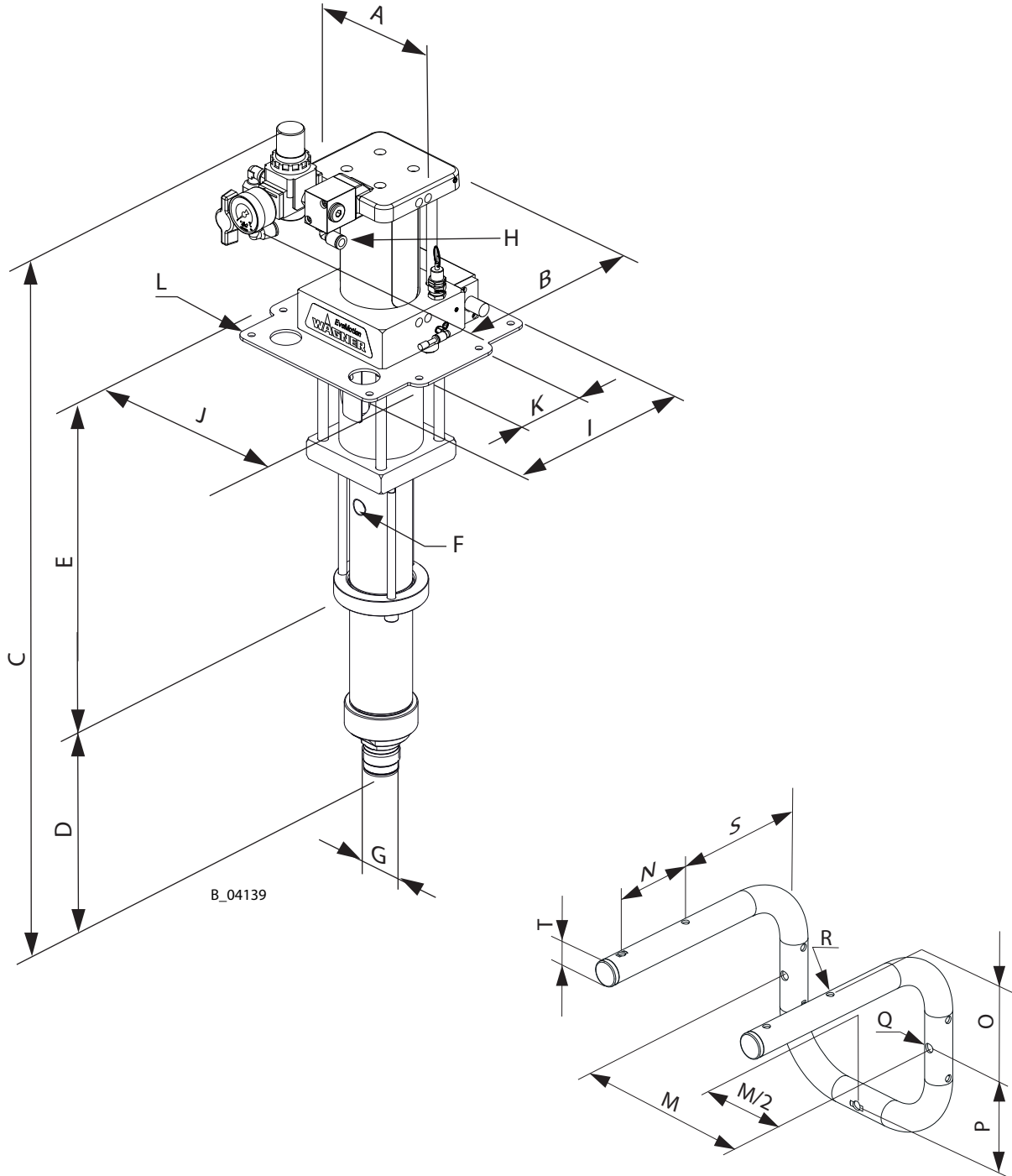

Pos	mm	inch
A	150	5.91
B	183	7.20
C	712	28.0
D	192	7.56
E	285	11.2
F	G 3/8"	

Pos	mm	inch
G	M36×2	
H	∅ 8	∅ 0.31
I	210	8.27
J	207	8.15
K	80	3.15
L	∅ 7	∅ 0.28
M	182	7.17
N	80	3.15
O	106	4.17
P	96.5	3.80
Q	∅ 9	∅ 0.35
R	∅ 7	∅ 0.28
S	149	5.87
T	∅ 25	∅ 0.98

5.5.5 Performance Diagrams

Example

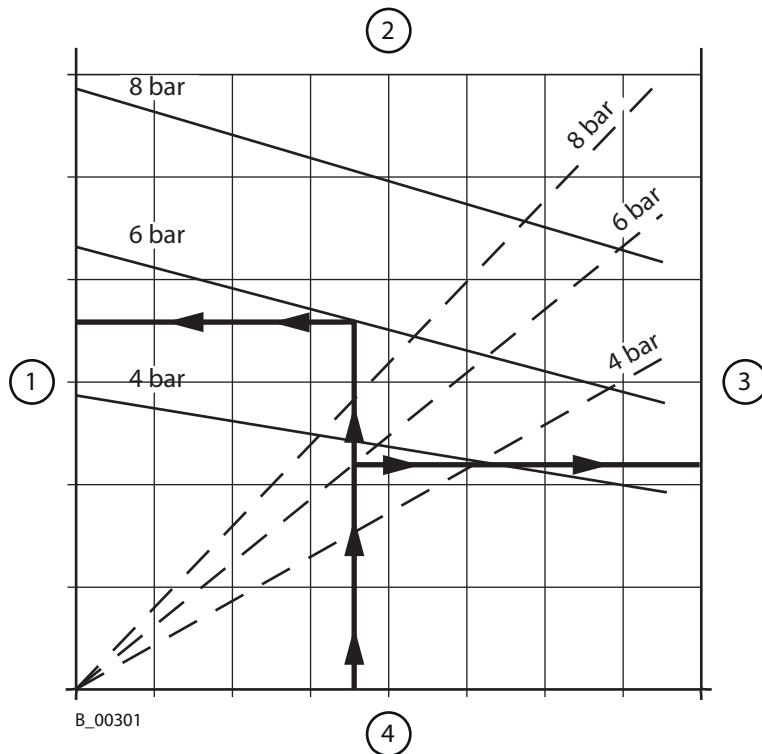

1	Product pressure in bar; (MPa); <psi>	3	Air consumption in nl/min.; <scfm>
2	Stroke frequency in DH/min.	4	Flow rate of water in l/min.; <gpm>

EvoMotion 5-60

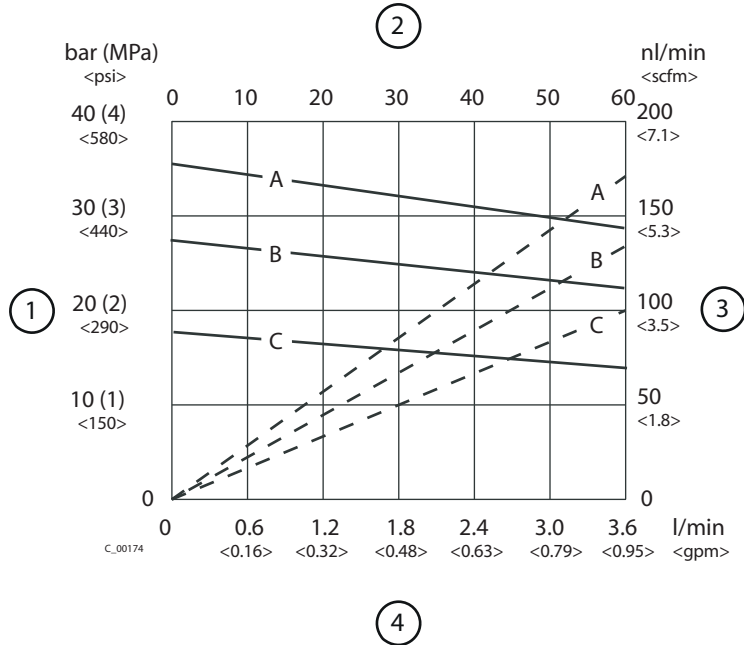

1	Product pressure in bar; (MPa); <psi>	A	Characteristic curve for air pressure 8 bar; 0.8 MPa; 116 psi
2	Stroke frequency in DH/min.	--	--
3	Air consumption in nl/min.; <scfm>	B	Characteristic curve for air pressure 6 bar; 0.6 MPa; 87 psi
4	Flow rate of water in l/min.; <gpm>	C	Characteristic curve for air pressure 4 bar; 0.4 MPa; 58 psi

5.6 OPERATING ELEMENTS

5.6.1 Pressure Regulator Unit

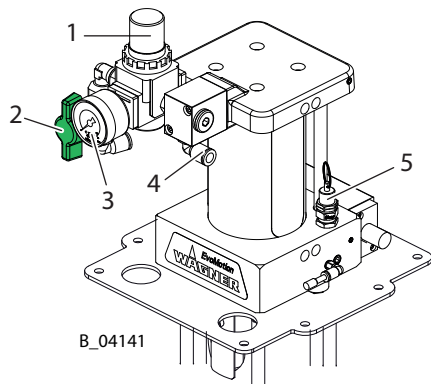

1	Pressure regulator	4	Compressed air input
2	Ball valve	5	Safety valve and pressure relief valve (see chapter Protective and Monitoring Equipment [▶▶ 19])
3	Pressure gauge (air inlet pressure)	--	--

Ball valve positions:

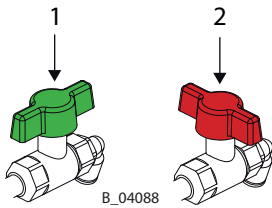

1	Open: working position	2	Closed: the air motor can still be under pressure
---	------------------------	---	---

5.6.2 Return valve

Installing a return valve is absolutely necessary for carrying out a complete depressurization of the pump (see Chapter Pressure Relief / Work Interruption [▶▶ 34]).

The suitable return valves (ball valves), return pipes and hoses for the device can be found in the accessories list.

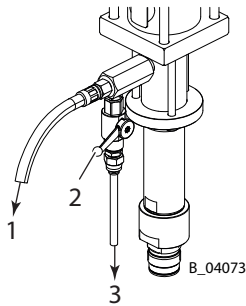

1	Product output	3	Material return line
2	Return valve	--	--

6 ASSEMBLY AND COMMISSIONING

6.1 TRAINING OF ASSEMBLY/COMMISSIONING PERSONNEL

- The assembly and commissioning personnel must have the technical skills to safely commission the device.
- When assembling, commissioning and carrying out all work, read and follow the operating manuals and safety regulations for the additionally required system components.

A skilled person must check to ensure that the device is in a reliable state after it is assembled and commissioned.

6.2 STORAGE CONDITIONS

Until the point of assembly, the device must be stored in a dry location, free from vibrations and with a minimum of dust. The device must be stored in closed rooms.

Die Lufttemperatur am Lagerort muss in einem Temperaturbereich zwischen -20 °C und +60 °C; -4 °F und +140 °F liegen.

The relative air humidity at the storage location must be between 10 and 95% (without condensation).

6.3 INSTALLATION CONDITIONS

The air temperature at the installation site must be in a range between 5 °C and 50 °C; 41 °F and 122 °F.

The relative air humidity at the installation site must be between 10 and 95% (without condensation).

6.4 TRANSPORTATION

The pump can be moved on a trolley or manually without lifting equipment or a crane.

6.5 ASSEMBLY AND INSTALLATION

WARNING

Inclined ground!

Risk of accidents if the device rolls away/falls.

- ▶ Place device on level ground and secure it.
- ▶ If the floor is inclined, position the feet of the trolley towards the gradient.
- ▶ Secure the trolley.



Info

Ensure that the national explosion prevention rules and regulations are observed when setting up the device.



This pump can be used as part of a spraying or feed system. Individual supplement components for this pump can be found in the Wagner accessories catalogue, or can be put together with a spraypack configurator. The nozzles must be selected according to the spray gun operating manual.

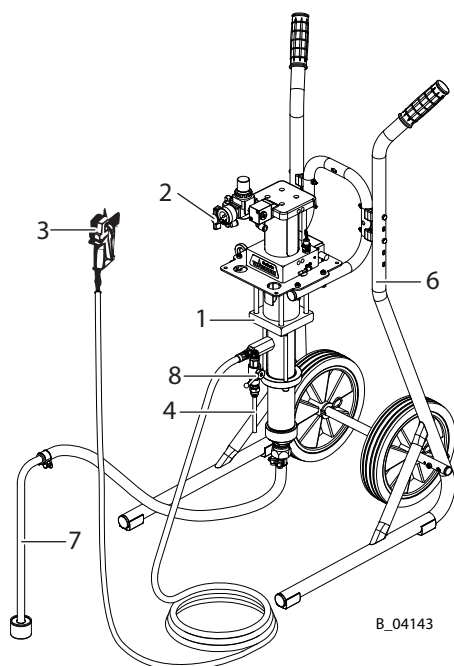

B_04143

1	Pump	5	--
2	Pressure regulator	6	Sliding tables
3	Spray gun	7	Suction system
4	Return tube	8	Return valve

1. Mount pump (1) on wall mount or trolley (6).
2. With an AirSpray system, fit the air hose on the spray gun and on the air line (cleaned compressed air).
3. Fit suction system (7).
4. Mount the return valve (8) for pressure relief or product circulation.
5. Mount return tube (4) or return hose.
6. Connect a suitable product shut-off valve or spray gun (3) in accordance with the spray gun operating manual.

6.5.1 Ventilation of the Spray Booth

- Operate the device in a spray booth approved for the respective working materials.
- or -
- Operate the device on an appropriate spraying wall with the ventilation (extraction) switched on.
- Observe national and local regulations for the exhaust air speed.

6.5.2 Air Supply Lines

WARNING

Hose connections!

Risk of injury and damage to the device.

- ▶ Do not mix up hose connections of product hose and air hose.
- ▶ Ensure that only dry, clean atomizing air is used in the spray gun! Dirt and moisture in the atomizing air worsens the spraying quality and spray pattern.



6.5.3 Product Supply Lines

DANGER

Bursting hose, bursting threaded joints!

Danger to life from injection of product.

- ▶ Ensure that the hose material is chemically resistant to the sprayed products.
- ▶ Ensure that the spray gun, fittings and product hose between the device and the spray gun are suitable for the pressure generated in the device.
- ▶ Ensure that the following information can be seen on the high-pressure hose:
 - ▶ Manufacturer
 - ▶ Permissible operating pressure
 - ▶ Date of manufacture.



6.6 GROUNDING

WARNING

Discharge of electrostatically charged components in atmospheres containing solvents!

Explosion hazard from electrostatic sparks.

- ▶ Clean the pump only with a damp cloth.



WARNING

Heavy paint mist if grounding is insufficient!

Risk of poisoning.

Insufficient paint application quality

- ▶ Ground all device components.
- ▶ Ground the work pieces to be coated.



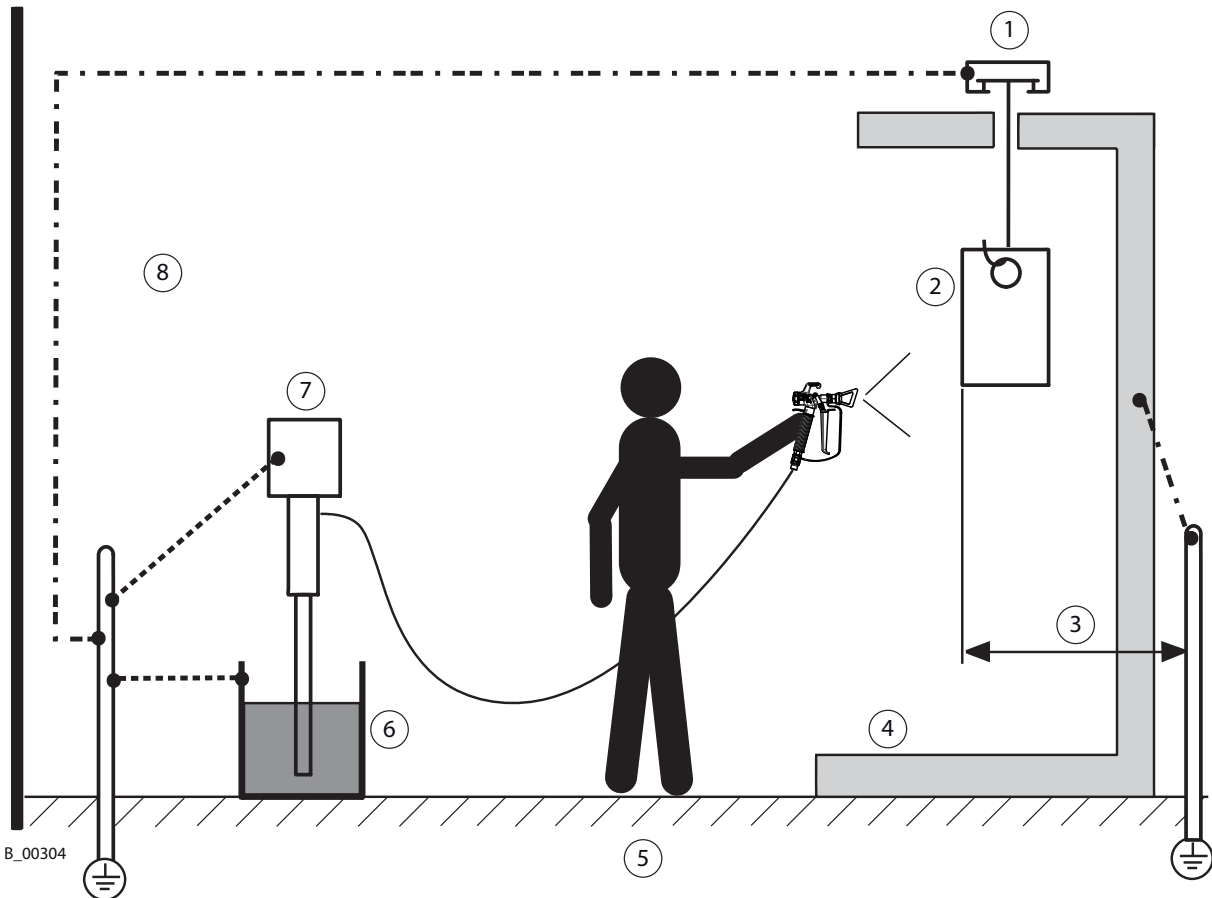

Grounding scheme (example)

Pos	Part / workstation	Cable cross section
1	Conveyor	16 mm ² ; AWG6
2	Work piece	--
3	$R_{\max} < 1 \text{ M}\Omega$	--
4	Spraying stand Alternative: Spray booth	16 mm ² ; AWG6
5	Floor, static dissipative	--
6	Product tank	6 mm ² ; AWG10
7	Pump	4 mm ² ; AWG12
8	Ex zone	--

Info

Safe operation of the pump is only guaranteed with a grounding connection. Connect all grounding cables using a short and direct route.

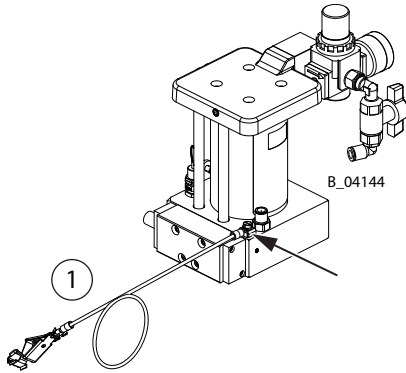

1	Grounding cable
---	-----------------

1. Screw on grounding cable with eyelet.
2. Clamp the grounding cable clip to a grounding connection on site.
3. Ground the product tank to an on-site grounding connection.
4. Ground the other parts of the system to an on-site grounding connection (16 mm²; AWG 6).

Ex zone

All devices and equipment must be suitable for use in potentially explosive areas.

- All paints, flushing agents and waste tanks have to be electrically conductive.
- All tanks must be grounded.

6.7 COMMISSIONING

WARNING

Gas mixtures can explode if there is an incompletely filled pump!

Danger to life from flying parts.

- ▶ Ensure that the pump and suction system are always completely filled with flushing agent or working medium.
- ▶ Do not spray the device empty after cleaning.



NOTICE

Impurities in the spraying system

Spray gun blockage, products harden in the spraying system.

- ▶ Flush the spray gun and paint supply with a suitable flushing agent before commissioning.

Emergency stop, see Chapter Emergency Stop [▶▶ 33].

6.7.1 Preparation

Before every commissioning, the following points should be observed as laid down in the operating manual:

1. Secure spray gun with safety lever.
2. Check the permissible pressures.
3. Check all connections for leaks.
4. Check hoses for damage in accordance with chapter Safety Checks and Maintenance Intervals [▶▶ 39].
5. Fill the separating agent in accordance with Chapter Filling with Separating Agent [▶▶ 40].

6.7.2 Fill the Pump with Flushing Agent

The devices are tested during manufacturing with emulsifying oil, pure oil or solvent. Possible residues must be flushed out of the circuits with a solvent (flushing agent) before commissioning.

- ▶ Fill the empty device with flushing agent in accordance with Chapter Filling the Empty Pump [▶▶ 43].

6.7.3 Pressure Tightness Test

WARNING

Overpressure!

Risk of injury from bursting components.

- ▶ The operating pressure must not exceed the value shown on the type plate.



1. Gradually increase the pressure in pump with the pressure regulator until maximum pressure is reached. Maintain the pressure for 3 minutes and check all connection points for leaks.
2. Carry out pressure relief in accordance with Chapter Pressure Relief / Work Interruption.

6.7.4 Verifying a Safe Operational Condition

A skilled person must check to ensure that the device is in a reliable state after it is assembled and commissioned. This includes:

- ▶ Carry out safety checks in accordance with Chapter Safety Checks and Maintenance Intervals [▶▶ 39].



6.7.5 Filling with Working Product

- ▶ Proceed in accordance with Chapter Filling the Empty Pump [▶▶ 43].

7 OPERATION

7.1 TRAINING THE OPERATING PERSONNEL

- The operating personnel must be qualified to operate the entire system.
- The operating staff must be familiar with the potential risks associated with improper behavior as well as the necessary protective devices and measures.
- Before work commences, the operating personnel must receive appropriate system training.

7.2 EMERGENCY STOP

In the case of unforeseen occurrences immediately:

1. Close ball valve (2).
2. Pull safety valve (5). Relieve the product-conveying parts of pressure via the return valve (8), or via the spray gun or an outlet valve in the product outlet (4).

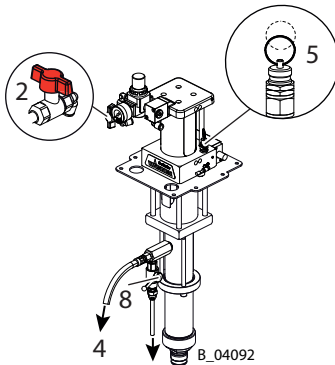

7.3 TASKS

Ensure that:

commissioning is carried out in accordance with Chapter Commissioning [>> 31].

1. Carry out a visual inspection: Personal protective equipment, grounding and all devices ready for use.
2. Secure spray gun (3) and insert nozzle into the spray gun.
3. Close return valve (8).
4. Slowly open the ball valve (2).
5. Set the required operating pressure on the pressure regulator (1).
6. Optimize spray pattern according to specifications in the spray gun operating manual.
7. Start work process.

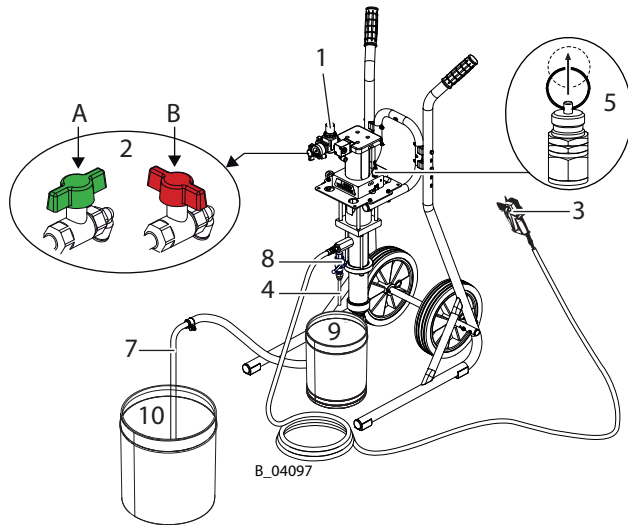

A	open	B	closed
---	------	---	--------

7.3.1 Feed System

After basic flushing, the pump can be filled with working material.

1. Close return valve (8).
2. Slowly open the ball valve (2).
3. Set the required operating pressure on the pressure regulator (1).
4. Open and close the outlet valve and/or the the lock units on the discharge duct in order to start and interrupt the product flow.

7.4 PRESSURE RELIEF / WORK INTERRUPTION

The pressure must always be relieved:

- after the spraying tasks are finished,
- before servicing or repairing the system,
- before carrying out cleaning tasks on the system,
- before moving the system to another location,
- before something needs to be checked on the system,
- before the nozzle or the filter is removed from the spray gun.

The components for pressure relief on a CE-compliant spraying system include:

- Air cock with pressure relief valve mounted between the compressed air source and the pneumatic pump. In this case, the pressure relief valve is the safety valve (5).
- Outlet equipment (return valve) mounted between pump and spray gun.

Process for relieving pressure

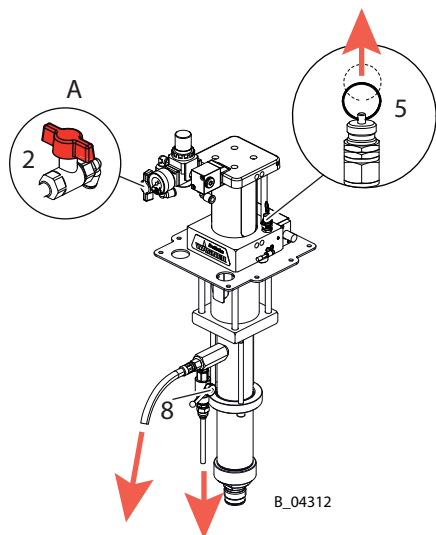

A	Closed
---	--------

1. Close the spray gun.
2. Close ball valve (2).
3. Release the system of pressure by opening the spray gun.
4. Close and secure the spray gun.
5. Open and close the return valve (8) slowly to completely depressurize the system.

Feed system: process for relieving pressure

1. Close the outlet valve and/or the lock units on the discharge duct.
2. Close ball valve (2).
3. Relieve the system pressure, by opening the return valve (8).
4. Close the return valve (8) again.

Note:Control air pressure is still present.

Pressure relief of the air (in case of longer work interruptions)

1. Carry out pressure relief of the product (as mentioned above).
2. Ensure that the ball valve (2) is closed.
3. Pull the ring on the safety valve (10) and hold it until the pressure in the air motor has been equalized.

⚠ NOTICE

Hardened working product in the spraying system when 2K product is processed!

Using 2K materials can destroy the pump and spraying system.

- ▶ Observe the manufacturer's processing rules, particularly in regards to the pot life.
- ▶ Flush thoroughly before the end of the pot life.
- ▶ The pot life is decreased by warmth.

7.5 BASIC FLUSHING

Regular flushing

- Regular flushing, cleaning and maintenance ensures the pump's high conveying and suction capacity.
- The cleaning and flushing agents used must be compatible with the working material.
- Do not flush hardener pumps with water. Only flush them using suitable flushing agents (solvents).

⚠ WARNING

Incompatibility of cleaning/flushing agent and working medium!

Risk of explosion and danger of poisoning by toxic gases.

- ▶ Examine the compatibility of the flushing and cleaning agents and working media on the basis of the safety data sheets.

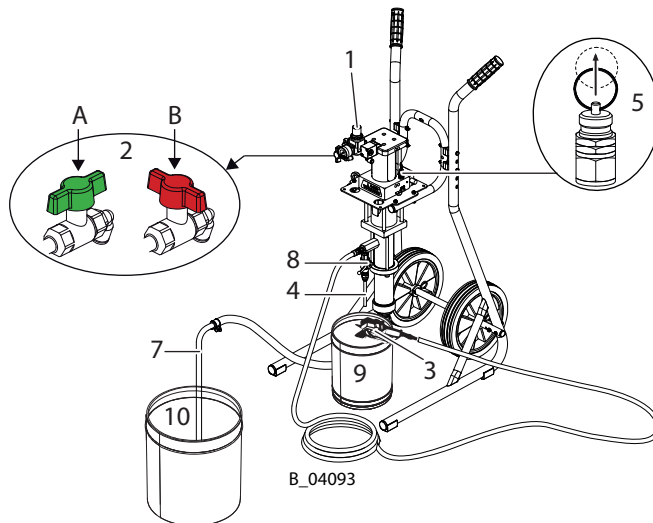

A	Open	B	Closed
---	------	---	--------

Before each basic flushing, the nozzle must be removed from the spray gun. Here, the specifications in the spray gun operating manual must be followed. With AirSpray systems, carry out the basic flushing of the system without atomizing air.

Preparation

1. Visual check: personal safety equipment, grounding and all devices ready to use.
2. Relieve the pump's pressure according to Chapter Pressure Relief / Work Interruption [▶▶ 34].
3. Place an empty, grounded collection tank (9) under the return tube (4).

4. Place the suction hose (7) in the grounded tank with flushing agent (10).
5. Open the ball valve (2) and set the pressure regulator (1) to approx. 0.05 MPa; 0.5 bar; 7.25 psi.

Flushing via the return valve

1. Open return valve (8).
2. Adjust the air pressure on the pressure regulator (1) so that the pump runs smoothly.
3. Flush the system until clean flushing agent flows into the tank (9).
4. Close ball valve (2).
5. As soon as there is no pressure remaining in the system, close the return valve (8).

Flushing via the gun

1. Point the spray gun (3), without nozzle, into the tank (9) and pull the trigger.
2. Slowly open the ball valve (2).
3. Rinse until clean flushing agent flows from the spray gun.
4. Close ball valve (2). Pull the ring on the safety valve (5) and hold it until the pressure in the air motor has been equalized.
5. Depressurize the system by either opening the return valve (8) or via the trigger on the spray gun (3).
6. As soon as there is no pressure remaining in the system, close the spray gun and/or return valve (8). Secure the spray gun.

External Cleaning

1. Clean the outside of the system.
2. Fully assemble the system.
3. Relieve the pump's pressure according to Chapter Pressure Relief / Work Interruption [▶▶ 34].
4. Dispose of the contents of the tank (9) according to the local regulations.

7.6 FILLING WITH WORKING PRODUCT

After basic flushing, the pump can be filled with working material.

- ▶ Proceed according to Chapter Filling the Empty Pump [▶▶ 43], but use working product instead of flushing agent.

8 CLEANING AND MAINTENANCE

8.1 CLEANING

8.1.1 Cleaning Personnel

Cleaning work should be undertaken regularly and carefully by qualified and trained personnel. They should be informed of specific hazards during their training.

The following hazards may arise during cleaning work:

- risk to health from inhaling solvent vapors,
- use of unsuitable cleaning tools and aids.

8.1.2 Decommissioning and Cleaning

The device should be cleaned for maintenance purposes, etc. Ensure that no remaining product dries on and sticks to the device.

1. Interrupt the work sequence in accordance with Chapter Pressure Relief / Work Interruption.
2. Carry out basic flushing in accordance with Chapter Basic Flushing [▶▶ 36].
3. Empty system in a controlled manner according to Chapter Emptying Pump [▶▶ 41].
4. Service spray gun in accordance to its operating manual.
5. Clean and check the suction system and the suction filter.
6. Clean the outside of the system.
7. Fully assemble the system.
8. Check fill level of the separating agent in accordance with Chapter Filling with Separating Agent [▶▶ 40].
9. Fill the system with flushing agent in accordance with Chapter Filling the Empty Pump [▶▶ 43].

8.1.3 Long-term Storage

If storing the system for a prolonged period of time, thorough cleaning and corrosion protection are necessary. Replace the water or solvent in the product pump with a suitable preserving oil and fill the separating agent tank with separating agent.

1. Carry out decommissioning and cleaning (steps 1 to 8) in accordance with Chapter Decommissioning and Cleaning [▶▶ 38].
2. Fill the system with preservation agent in accordance with Chapter Filling the Empty Pump [▶▶ 43].
3. Empty the system in a controlled manner in accordance with Chapter Emptying Pump [▶▶ 41] and seal the openings.

8.2 MAINTENANCE

8.2.1 Maintenance Personnel

Maintenance work should be undertaken regularly and carefully by qualified and trained personnel. They should be informed of specific hazards during their training.

The following hazards may arise during maintenance work:

- risk to health from inhaling solvent vapors,
- use of unsuitable tools and aids.

A skilled person must ensure that the device is checked for being in a reliable state after maintenance work is completed.

8.2.2 Maintenance Instructions

DANGER

Incorrect maintenance/repair!

Danger to life and equipment damage.

- ▶ Only a WAGNER service center or a suitably trained person may carry out repairs and replace parts.
- ▶ Use only WAGNER original spare parts and accessories.
- ▶ Only repair and replace parts that are listed in the spare parts chapter and that are assigned to the device.
- ▶ Before all work on the device and in the event of work interruptions:
 - ▶ Relieve the pressure from the spray gun, product hoses and all devices.
 - ▶ Secure the spray gun against actuation.
 - ▶ Switch off the energy and compressed air supply.
 - ▶ Disconnect the control unit from the mains.
- ▶ Observe the operating and service manual for all work.



Prior to maintenance

It should be ensured that the device is in the following state before carrying out any work on it:

- Flush and clean the system according to Chapter Decommissioning and Cleaning [▶▶ 38].
- Interrupt the air supply.

After maintenance

- Carry out safety checks in accordance with Chapter Safety Checks and Maintenance Intervals [▶▶ 39].
- Put the system into operation and check for leaks as described in Chapter Commissioning [▶▶ 31].
- Have the system checked for safe condition by a skilled person.
- Carry out functional check in accordance with Chapter Function Test after Repair Work [▶▶ 48].

8.2.3 Safety Checks and Maintenance Intervals

Every day

1. Check grounding: see Chapter Grounding [▶▶ 29].
2. Check hoses, tubes and couplings: see Chapter Product Hoses, Pipes and Couplings [▶▶ 40]
3. Check the level of separating agent in the separating agent tank and top up, if necessary, in accordance with chapter Filling with Separating Agent [▶▶ 40].
4. For each decommissioning, the process according to Chapter Decommissioning and Cleaning [▶▶ 38] must be followed.
5. If the pump has to be emptied for maintenance work, proceed according to Chapter Emptying Pump [▶▶ 41].

Weekly

1. Check system for damage.
2. Check that the safety fixtures function properly (see Chapter Protective and Monitoring Equipment [▶▶ 19]).

Yearly or as required

1. In accordance with DGUV regulation 100-500, Chapters 2.29 and 2.36:
 - ▶ Have the liquid ejection devices checked by an expert (e.g. WAGNER service technician) as required, but no later than every 12 months to ensure that they are in safe working order.
 - ▶ For shut down devices, the examination can be suspended until the next start-up.

8.2.4 Filling with Separating Agent

⚠ NOTICE

Piston pump dry run

High wear/damage to the packings.

Paint or solvent can escape if the seals are dry.

- ▶ Ensure that the separating agent tank is filled with sufficient separating agent.

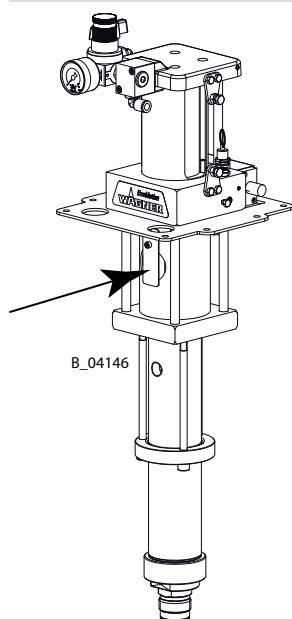

Pour the supplied separating agent into the separating agent container.

Filling level: 2 cm; 0.8 inch under the filling opening.

Separating agent: order no. 9992504

Inclination angle of the pump

Maximum permissible inclination of pump for moving, transportation etc. after filling with separating agent is $\pm 30^\circ$. The pump must be vertical during operation.

8.2.5 Product Hoses, Pipes and Couplings

The service life of the complete hoses between product pressure generator and application device is reduced due to environmental influences even when handled correctly.

1. Check hoses, pipes, and couplings every day and replace if necessary.
2. Before every commissioning, check all connections for leaks.
3. Additionally, the operator must regularly check the complete hoses for wear and tear as well as for damage at intervals that he/she has set. Records of these checks must be kept.
4. Replace the complete hose if one of the following two periods is exceeded:
 - ▶ 6 years from the date of the hose crimping (see fitting embossing).
 - ▶ 10 years from the date of the hose imprinting.

Fitting embossing (if present)	Meaning
xxx bar	Pressure
yymm	Crimping date (year/month)
XX	Internal code
Hose imprinting	Meaning
WAGNER	Name / manufacturer
yymm	Date of manufacture (year/month)
xxx bar (xx MPa) e.g. 270 bar (27MPa)	Pressure
XX	Internal code
DNxx (e.g., DN10)	Nominal diameter

8.2.6 Emptying Pump

WARNING

Gas mixtures can explode if there is an incompletely filled pump!

Danger to life from flying parts.

Ignition of potentially explosive surrounding atmosphere.

- ▶ Empty and fill the device slowly and in a controlled manner.
- ▶ Avoid potentially explosive atmosphere in the surroundings.



Info

If the pumping product becomes heated, switch off all heaters and let the product cool off.



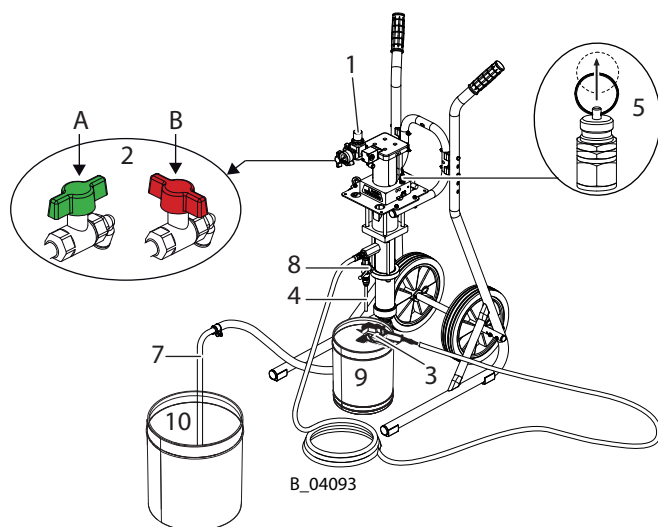

A	Open	B	Closed
---	------	---	--------

1. Visual check: personal safety equipment, grounding and all devices ready to use.
2. Place an empty, grounded collection tank (9) under the return tube (4).
3. Place the suction hose (7) in an empty, grounded tank (10).
4. Close pressure regulator (1) (0 MPa; 0 bar; 0 psi).

Emptying via return line

1. Open return valve (3).
2. Slowly open the ball valve (2).
3. Slowly dial up the air pressure at the pressure regulator (1) until the pump operates smoothly (approx. 0.05 MPa; 0.5 bar; 7.25 psi).
4. Be ready for the switch from working product to air. Turn down pressure regulator (1) far enough that the pump is still running normally (approx. 0–0.05 MPa; 0–0.5 bar; 0–7.25 psi).
5. As soon as working product is no longer flowing from the return tube (4), close the ball valve (2).
6. Close return valve (3).

Emptying via the spray gun

1. Point the spray gun (3), without nozzle, into the tank (9) and pull the trigger.
2. Slowly open the ball valve (2). Be ready for the switch from working product to air.
3. As soon as no more working product is flowing, close the ball valve (2).
4. Close and secure the spray gun.
5. Carry out pressure relief in accordance with Chapter Pressure Relief / Work Interruption [▶▶ 34].
6. Dispose of the contents of the tank (9) according to the local regulations.

8.2.7 Filling the Empty Pump

WARNING

Gas mixtures can explode if there is an incompletely filled pump!

Danger to life from flying parts.

Ignition of potentially explosive surrounding atmosphere.

- ▶ Empty and fill the device slowly and in a controlled manner.
- ▶ Avoid potentially explosive atmosphere in the surroundings.

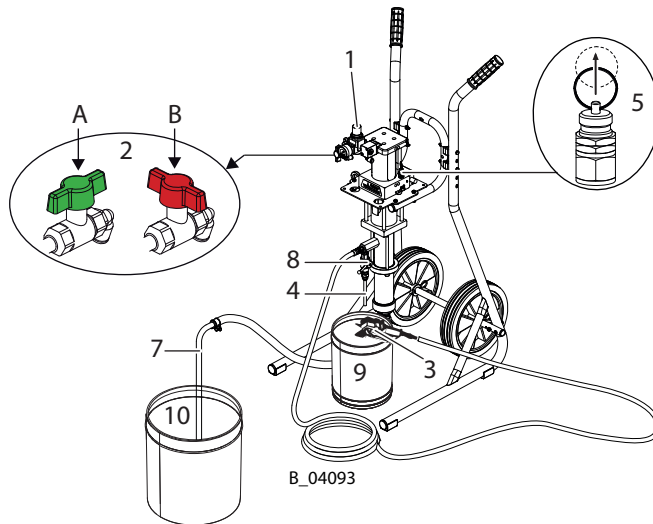

A	Open	B	Closed
---	------	---	--------

1. Carry out a visual inspection: Personal protective equipment, grounding and all devices ready for use.
2. Place an empty, grounded collection tank (9) under the return tube (4).
3. Place suction hose (7) in the tank with working material (10).
4. Close the pressure regulator (1) (0 MPa; 0 bar; 0 psi)
5. Open return valve (8).
6. Slowly open the ball valve (2).
7. Slowly turn up the air pressure on the pressure regulator (1). Only turn up the air pressure until the pump is running normally.
Be prepared to switch from air to working product and prevent back spray.
8. Close ball valve (2) as soon as pure working product starts coming from the return tube (4).
9. Close return valve (8).
10. Open the outlet valve or spray gun (3), and then slowly open the ball valve (2) in order to fill the discharge duct.
11. Close ball valve (2) as soon as pure working product without air bubbles starts coming from the gun.
12. Carry out pressure relief in accordance with Chapter Pressure Relief / Work Interruption [▶▶ 34].
13. Dispose of the contents of the tank (9) according to the local regulations.

9 TROUBLESHOOTING AND RECTIFICATION

Malfunction	Cause	Remedy
The pump does not work.	The pump does not start or stops.	Open and close ball valve on the pressure regulator unit or briefly disconnect compressed air supply.
	No pressure indication on the pressure gauge (air pressure regulator defective).	Disconnect compressed air supply briefly or repair or change pressure regulator.
	Spray nozzle is clogged.	Clean the nozzle according to the instructions.
	Insufficient compressed air supply.	Check compressed air supply.
	Filter insert in spray gun is clogged.	Clean the parts and use a suitable working material.
	Fluid section or high-pressure hose is blocked (e.g., 2K product hardened).	Dismount and clean fluid section, replace high-pressure hose.
	Sometimes, the pump stops at a switching point.	Press the starter on the reverse valve and restart the pump. Replace the reversing valve if necessary.
Poor spray pattern.	The fluid section sucks in air.	Check the level of the working product. Fill the tank.
Irregular operation of product pump: Spray jet collapses (pulsation).	Air in the fluid section.	Vent the system: Suction the product without a spray nozzle.
	Viscosity is too high.	Thin spraying product.
	Spraying pressure is too low.	Increase incoming air pressure. Use a smaller nozzle.
	Valves are clogged.	Clean pump. If necessary, leave it to soak in cleaning agent.
	Foreign body in suction valve.	Dismantle suction valve housing, clean and check valve seat.
	Diameter of compressed air line too small.	Assemble a larger supply line -> chapter Technical Data [▶▶ 21]
	Valves, packings, or pistons are worn out.	Replace the parts.
The pump runs evenly, but does not suck up any product.	On-site air filter is clogged.	Check and clean it if necessary.
	The suction system's union nut is loose; the pump is taking in air.	Tighten union nut.
	Air in the fluid section.	Vent the system: Suction the product without a spray nozzle.
	Suction filter is clogged.	Clean filter.
The pump runs when the discharge duct is closed.	Ball in suction or piston valve is stuck.	Clean balls and valve seats. (If necessary, vent device.)
	Packings, valves, or pistons are worn out.	Replace the parts.
Air motor is iced up.	There is a lot of condensation water in the air supply.	Install a water separator.



If none of the causes of malfunction mentioned are present, the defect can be remedied by a WAGNER service center.

10 REPAIRS

10.1 REPAIR PERSONNEL

Repair work should be undertaken carefully by qualified and trained personnel. They should be informed of specific hazards during their training.

The following hazards may arise during repair work:

- risk to health from inhaling solvent vapors,
- use of unsuitable tools and aids.

A skilled person must check to ensure that the device is in a reliable state after it is repaired. A function test should be performed.

10.2 REPAIR NOTES

DANGER

Incorrect maintenance/repair!

Danger to life and equipment damage.

- ▶ Only a WAGNER service center or a suitably trained person may carry out repairs and replace parts.
- ▶ Use only WAGNER original spare parts and accessories.
- ▶ Only repair and replace parts that are listed in the spare parts chapter and that are assigned to the device.
- ▶ Before all work on the device and in the event of work interruptions:
 - ▶ Relieve the pressure from the spray gun, product hoses and all devices.
 - ▶ Secure the spray gun against actuation.
 - ▶ Switch off the energy and compressed air supply.
 - ▶ Disconnect the control unit from the mains.
- ▶ Observe the operating and service manual for all work.



Before Repair Work

It should be ensured that the device is in the following state before carrying out any work on it:

1. Flush and clean the system according to Chapter Decommissioning and Cleaning [▶▶ 38].
2. Interrupt the air supply.

After Repair Work

1. Carry out safety checks in accordance with Chapter Safety Checks and Maintenance Intervals [▶▶ 39].
2. Put the system into operation in accordance with Chapter Commissioning [▶▶ 31] and check for leaks in accordance with Chapter Function Test after Repair Work [▶▶ 48].
3. Have the system checked for safe condition by a skilled person.
4. Carry out functional check in accordance with Chapter Function Test after Repair Work [▶▶ 48].

10.3 TOOLS

The following tools are required for assembling and disassembling the device (if possible, always bring entire tool sets with you):

- Torque wrench 2.5 Nm; 1.84 lbft / 5; 3.7 / 10; 7.4 / 15; 11.1 / 30; 22.1 / 40; 29.5
- Set of circlip pliers
- Set of slot-head screwdrivers
- Set of Phillips screwdrivers
- Set of Allen wrenches
- Set of wrenches

10.4 CLEANING THE PARTS AFTER DISASSEMBLY

WARNING

Incompatibility of cleaning agent and working medium!

Risk of explosion and danger of poisoning by toxic gases.

- ▶ Examine the compatibility of the cleaning agents and working media on the basis of the safety data sheets.



Please note:

1. Thoroughly clean all reusable parts with a suitable cleaning agent.
2. All dismantled parts have to be clean and dry after cleaning. Care should be taken that these parts remain free of solvents, grease or sweat from the hands (salt water). Perform cleaning and mounting tasks wearing gloves.

10.5 ASSEMBLY OF THE DEVICE

In Chapter Spare Parts [▶▶ 53] the order numbers for device spare parts can be found, as well as for wearing parts such as seals.

1. Defective parts, O-rings and seal sets must always be replaced.
2. Use greases and glues in accordance with Chapter Spare Parts [▶▶ 53].
3. Observe torque specifications in Chapter Spare Parts [▶▶ 53].

Assembly aids:

Order no.	Quantity	Designation	Smaller tanks
9992590	1 pc \triangleq 50 ml	Loctite® 222	
9992511	1 pc \triangleq 50 ml	Loctite® 243	
9992831	1 pc \triangleq 50 ml	Loctite® 542	
9998808	1 pc \triangleq 18 Kg!	Mobilux® EP 2 grease	400 g tube \triangleq order no. 2355418
9992616	1 pc \triangleq 1 kg can	Molykote® DX grease	50 g tube \triangleq order no. 2355419
9992609	1 pc \triangleq 100 g	Anti-seize paste	
9992816	1 pc \triangleq 70 g	Miranit contact adhesive	

Brand notice

The brands specified in this document are property of the respective owners. Loctite®, for example, is a registered brand of Henkel.

11 FUNCTION TEST AFTER REPAIR WORK

After all repairs, the device must be checked for safe condition before recommissioning. The necessary scope of inspection and testing depends on the repair carried out and must be documented by the repair personnel.

Activity	Aid tools
1.1 Filling with separating agent	
▶ See Chapter Filling with Separating Agent [▶▶ 40].	
1.2 EX-relevant inspections	
1. Check the ground connection between the corresponding ground connection of the pump and the frame/trolley, and between the individual parts of the frame/trolley: $<100\text{ k}\Omega$ 2. Check conductivity between the piston and the grounding connection: $<100\text{ k}\Omega$ These tests are  -relevant!	Ohmmeter (Measurement voltage 500...1000 VDC)
1.3 Testing for leaks	
1. Connect the air motor to the air supply (7 bar). 2. To perform a tightness check on the device, the product pressure with the flushing agent is slowly increased in increments until the maximum pressure indicated on the type plate is reached. 3. Close pump outlet. 4. In each position (with upstroke and downstroke), let sit for 0.5-1 minute(s) and listen for audible blowing off. 5. When the air supply is turned off, a drop in pressure must be watched for. 6. Check seal of following modules: - fluid section - mounted valves and regulators	Air motor: Test medium: Com-pressed air Leak spray Fluid section: Test medium: Suitable flushing agent
1.4 General inspections	
1. Check the tightening torques of various screws; see Chapter Spare Parts [▶▶ 53]. 2. Check all fittings. 3. Empty device in a controlled manner (Chapter Emptying Pump [▶▶ 41]) and depressurize (Chapter Pressure Relief / Work Interruption). 4. Check the functionality of the frame or transport trolley.	Torque wrench Visual check

12 DISPOSAL

12.1 DEVICE

When the devices must be scrapped, please differentiate the disposal of the waste materials.

The following materials have been used:

- Stainless steel
- Aluminum
- Elastomers
- Plastics
- Carbide

12.2 CONSUMABLE PRODUCTS

Consumable products (lacquers, adhesives, flushing and cleaning agents) must be disposed of in accordance with all applicable legal requirements.

13 ACCESSORIES

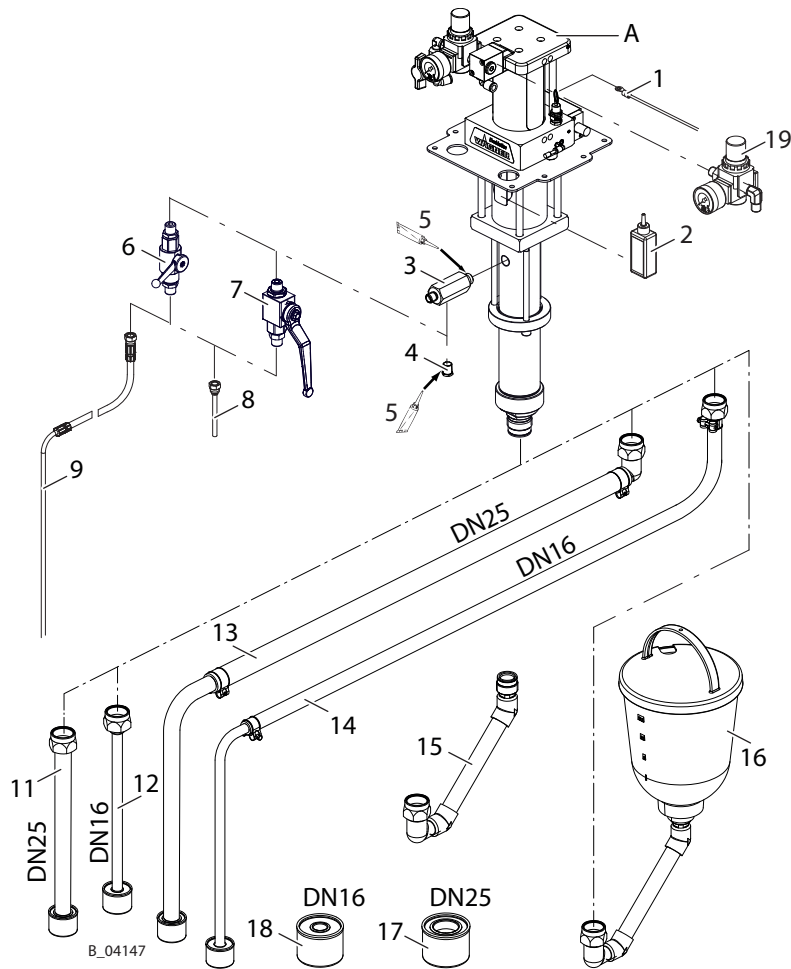

Pos	K	Order no.	Designation
A		2329535	Piston pump
A		2330596	Piston pump for sensor
1		236219	Grounding cable, complete 3 m; 9.8 ft
2		9992504	Separating agent 250 ml; 250 cc
2		9992505	Separating agent 500 ml; 500 cc
3		B0461.03	Fitting DF-MM-R3/8"-1/4"NPS-PN350
4		2323718	Hexagon plug
5		9992528	Loctite® 270
6	◆	2334488	Ball valve, R1/4"-G1/4"-PN350-SSt
7	◆	2334472	Ball valve R1/4"-G1/4"-PN350-CS
8	◆	2331752	Return tube, DN6-G1/4"-100mm-PA
9	◆	2329046	Return hose DN6-PN310-G1/4"-PA
11		2323239	Suction tube DN25-SSt, complete
12		2324158	Suction tube DN16-SSt, complete
13	◆	2324116	Suction hose, DN25-SSt, complete

Pos	K	Order no.	Designation
14	◆	2324110	Suction hose, DN16-SSt, complete
15		2323225	Suction elbow for hopper SSt
16	◆	2332169	Hopper set, 5 l for piston pump
17	◆	2323325	Suction filter, DN25-18mesh-SSt
18	◆	2323396	Suction filter, DN16-18 mesh-SSt
19		2391922	EvoMotion AirCoat regulator set

◆ = wearing parts

13.1 WALL MOUNT AND TROLLEY

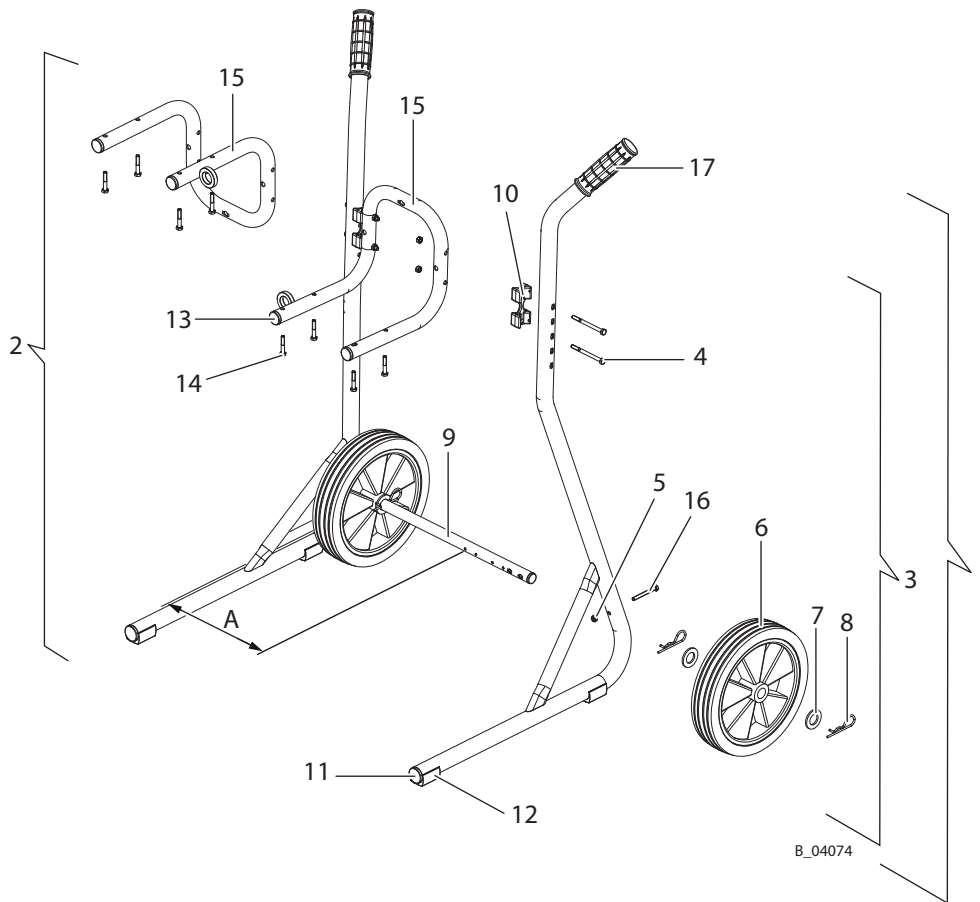

Pos	K	Stk	Order no.	Designation
1		1	2325901	Trolley, complete
2		1	--	Frame left 4" (welded)
3		1	--	Frame right 4" (welded)
4		4	9907140	Hexagon screw DIN931, M6x75
5		6	9910204	Self-locking hexagon nut, M6
6	◆	2	2304440	Wheel, D250
7		4	340372	Washer
8		4	9995302	Cotter pin
9		1	--	Wheel axle 4"

Pos	K	Stk	Order no.	Designation
10	◆	2	367943	Connecting part 4"
11		2	--	Tube plug, ribbed
12		2	--	Saddle feet for round tubes
13		2	--	Plug
14		4	9900218	Hexagon screw
15		1	2332143	Wall mount
16		2	3061695	Hexagon screw without shaft, M6x55
17	◆	2	9998747	Handle

◆ = wearing parts

14 SPARE PARTS

14.1 HOW CAN SPARE PARTS BE ORDERED?

Always supply the following information to ensure delivery of the right spare part:

Order number, designation and quantity

The quantity need not be the same as the number given in the "Stk" column in the lists. This number merely indicates how many of the respective parts are used in each component.

The following information is also required to ensure smooth processing of your order:

- billing address
- delivery address
- name of the person to be contacted in the event of any queries
- type of delivery (normal mail, express delivery, air freight, courier etc.)

Identification in spare parts lists

Explanation of column „K“ (marking) in the following spare parts lists:

◆ Wearing parts. Wearing parts are not included in the warranty.

* = included in service set

● not part of the standard equipment but available as a special accessory

Explanation of order no. column:

-- Item not available as spare part.

/ Position does not exist.

14.2 NOTES ON USING SPARE PARTS

DANGER

Incorrect maintenance/repair!

Danger to life and equipment damage.

- ▶ Only a WAGNER service center or a suitably trained person may carry out repairs and replace parts.
- ▶ Use only WAGNER original spare parts and accessories.
- ▶ Only repair and replace parts that are listed in the spare parts chapter and that are assigned to the device.
- ▶ Before all work on the device and in the event of work interruptions:
 - ▶ Relieve the pressure from the spray gun, product hoses and all devices.
 - ▶ Secure the spray gun against actuation.
 - ▶ Switch off the energy and compressed air supply.
 - ▶ Disconnect the control unit from the mains.
- ▶ Observe the operating and service manual for all work.



14.3 OVERVIEW OF THE COMPONENTS

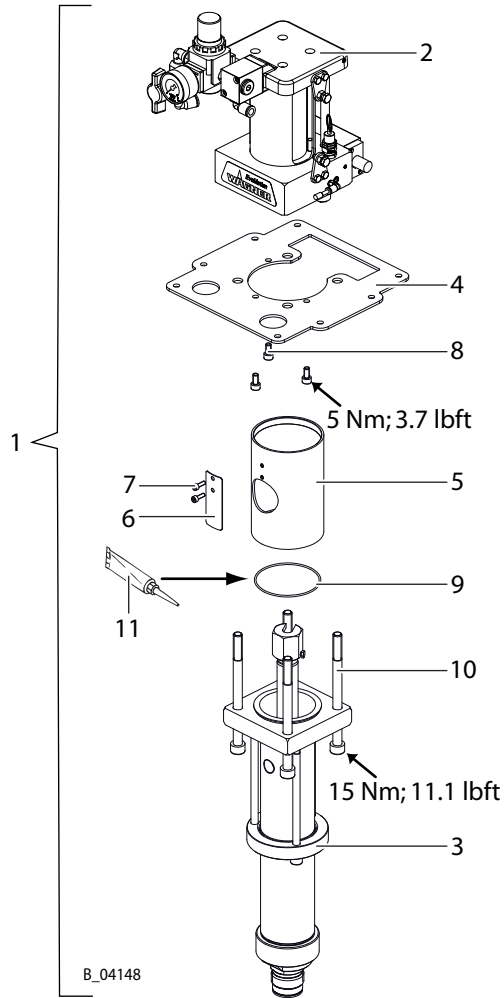

Pos	K	Stk	Without sensor Order no.	With sensor Order no.	Designation
1		1	2329535	2330596	EvoMotion 5-60 PE/T
2		1	U3B05012075	U3B05012075S	Air motor M50 EM
3		1	2329681		Fluid section 60 PE/T EM
4		1	2332394		Pump support plate
5		1	A359.71B		M/P spacer tube
6		1	E516.71A		Safety fixture spacer
7		2	9900353		Hexagon socket head cap screw
8		3	9900346		Hexagon socket head cap screw
9		1	L236.06A		O-ring
10		4	9900385		Hexagon socket head cap screw
11		1	9998808		Mobilux® EP 2 grease

14.4 M50 AIR MOTOR WITH EM FIXING SENSOR

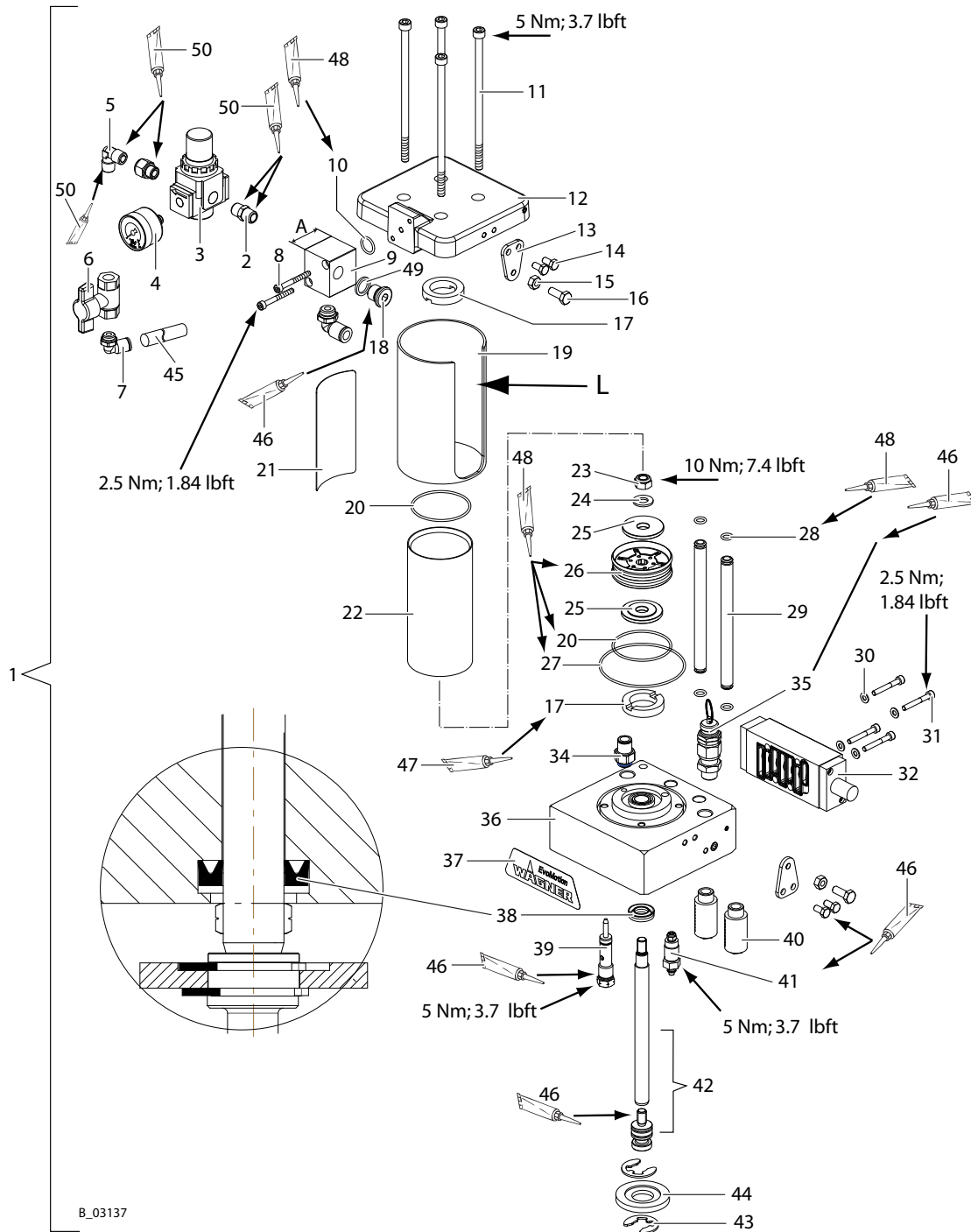

Installation instructions

Insert piston rod (42 upper) from above and then secure the coupling pins (42 lower) with Loctite® 542.

Carefully break out the flap "L".

Pos	K	Stk	Order no.	Designation
1		1	U3B05012075S	M50 Air Motor, EM sensor
2		1	M205.04	Double nipple
3		1	2384362	Air pressure regulator (new, starting from serial no. 1422)
4		1	9998677	Pressure gauge
5		1	9998039	Elbow fitting
6		1	M106.00	Ball valve
7		2	9998253	Male stud elbow
8		2	9906005	Hexagon socket head cap screw (old)
		2	2334205	Hexagon socket head cap screw (new, starting from serial no. 1422)
9		1	T162.71	Housing air ([new, starting from serial no. 1422], Measurement A = 38mm)
10	◆*	1	9971123	O-ring
11		4	K1081.62	Hexagon socket head cap screw
12		1	T6191.00	Upper flange motor, complete M50 EM
13		2	E3366.03	Fixing plate sensor
14		4	9900129	Hexagon screw without shaft
15		2	9910102	Hexagon nut
16		2	9907198	Hexagon screw without shaft
17	◆*	2	G903.06	Damper
18		1	9904307	Locking screws with collar/hexagon socket
19		1	E0109.71	EM M50 guard tube
20	◆*	2	L102.06	O-ring
21		1	--	Type Plate
22		1	D636.71	Cylinder motor
23		1	9910208	Hexagon nut with clamp
24		1	9920102	Washer
25		2	B0445.01	Piston washer
26	◆	1	R0074.00	Piston seal
27		1	L236.06A	O-ring
28		4	L109.06	O-ring
29		2	B0444.71	Air tube, M50 EM
30		4	9920104	Washer
31		4	9900386	Hexagon socket head cap screw
32	◆	1	P498.00	Reversing Valve
34		1	9998254	Straight screw-in fitting
35		1	P484.00C0	Safety valve 1/4", blue ring
36		1	T6003.00EB	Lower flange motor, complete
37		1	Z5032.00	WAGNER EvoMotion label
38	◆*	1	L434.06	Lip seal
39	◆	1	2341115	Pilot valve
40	◆*	2	H505.07	Silencer
41	◆	1	2339340	Sensor Down

Pos	K	Stk	Order no.	Designation
42		1	T6190.00	Piston rod, complete - motor
43		2	K606.02	Lock washer for waves
44		1	A160.01A	Washer
45		1	9982078	Hose, black
46		1	9992831	Loctite® 542
47		1	9998157	Loctite® 480
48		1	9998808	Mobilux® EP 2 grease
49	◆*	1	9970154	Sealing ring
50		1	9992528	Loctite® 270
	●	1	T9096.00	EvoMotion 5-60 air motor service set

◆ = wearing parts

* = Included in service set

● = Not part of the standard equipment but available as an accessory.

14.5 M50 AIR MOTOR WITHOUT EM FIXING SENSOR

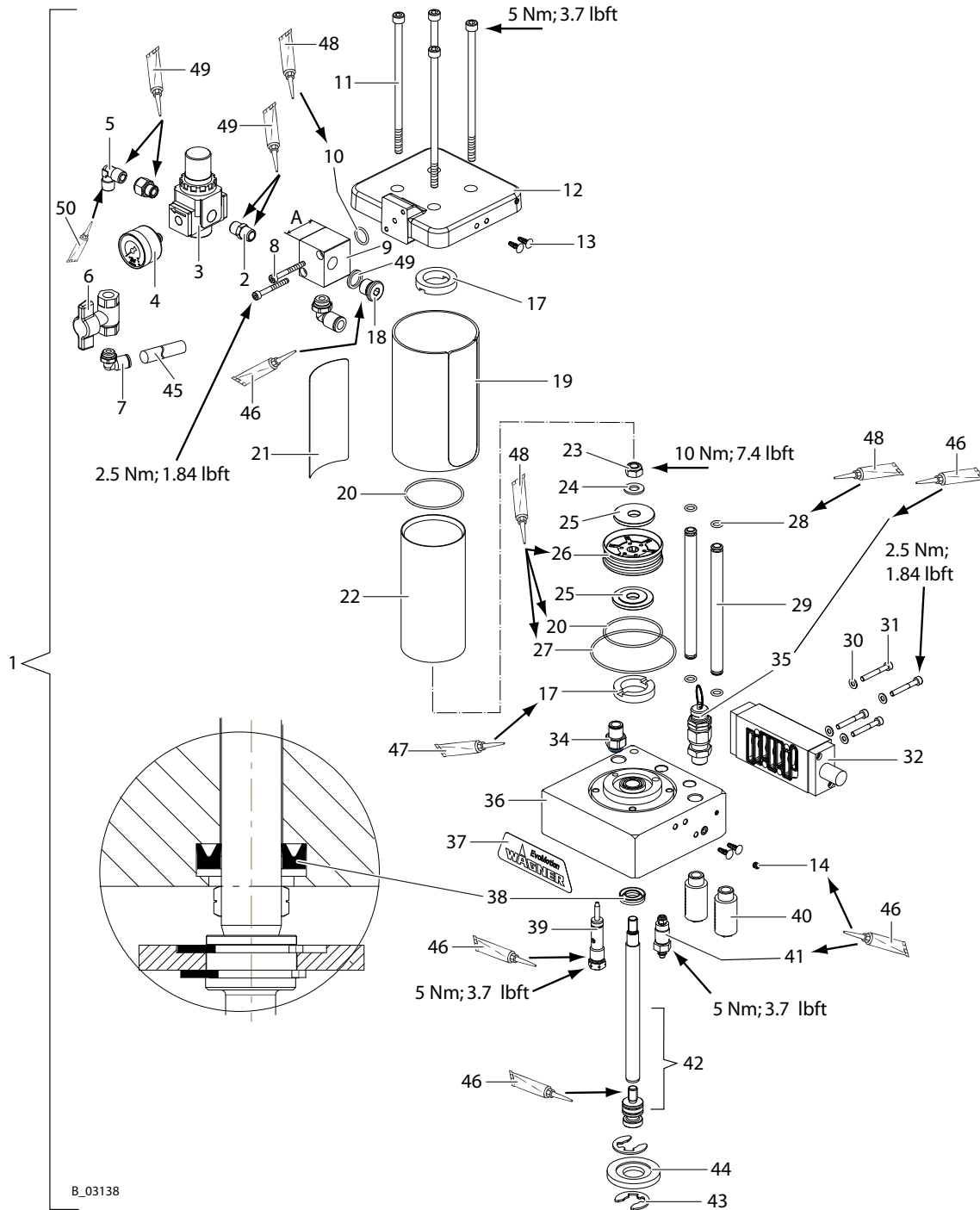

Installation instructions

Insert piston rod (42 upper) from above and then secure the coupling pins (42 lower) with Loctite® 542.

Pos	K	Stk	Order no.	Designation
1		1	U3B05012075	M50 Air Motor, without EM Sensor
2		1	M205.04	Double nipple
3		1	2384362	Air pressure regulator (new, starting from serial no. 1422)

Pos	K	Stk	Order no.	Designation
4		1	9998677	Pressure gauge
5		1	9998039	Elbow fitting
6		1	M106.00	Ball valve
7		2	9998253	Male stud elbow
8		2	9906005	Hexagon socket head cap screw (old)
		2	2334205	Hexagon socket head cap screw (new, starting from serial no. 1422)
9		1	T162.71	Housing air (new, starting from serial no. 1422, measurement A = 38mm)
10	◆*	1	9971123	O-ring
11		4	K1081.62	Hexagon socket head cap screw
12		1	T6191.00	Upper flange motor, complete
13		4	R256.00	Drive fastener
14		1	9907109	Threaded pin with hexagon socket
17	◆*	2	G903.06	Damper
18		1	9904307	Locking screws with collar/hexagon socket
19		1	E0109.71	EM M50 guard tube
20	◆*	2	L102.06	O-ring
21		1	--	Type Plate
22	◆*	1	D636.71	Cylinder motor
23		1	9910208	Hexagon nut with clamp
24		1	9920102	Washer
25		2	B0445.01	Piston washer
26	◆	1	R0074.00	Piston seal
27	◆*	1	L236.06A	O-ring
28	◆*	4	L109.06	O-ring
29		2	B0444.71	Air tube - motor
30		4	9920104	Washer
31		4	9900386	Hexagon socket head cap screw
32	◆	1	P498.00	Reversing Valve
34		1	9998254	Straight screw-in fitting
35		1	P484.00C0	Safety valve
36		1	T6003.00EB	Lower flange motor, complete M50E
37		1	Z5032.00	WAGNER EvoMotion label
38	◆*	1	L434.06	Lip seal
39	◆	1	2341115	Pilot valve
40	◆*	2	H505.07	Silencer
41	◆	1	2339340	Sensor Down
42		1	T6190.00	Piston rod, complete - motor
43		2	K606.02	Lock washer for waves
44		1	A160.01A	Washer

Pos	K	Stk	Order no.	Designation
45		1	9982078	Hose, black
46		1	9992831	Loctite® 542
47		1	9998157	Loctite® 480
48		1	9998808	Mobilux® EP 2 grease
49	◆*	1	9970154	Sealing ring
50		1	9992528	Loctite® 270
	●	1	T9096.00	EvoMotion 5-60 air motor service set

◆ = wearing parts

* = Included in service set

● = Not part of the standard equipment but available as an accessory.

14.6 REVERSING VALVE

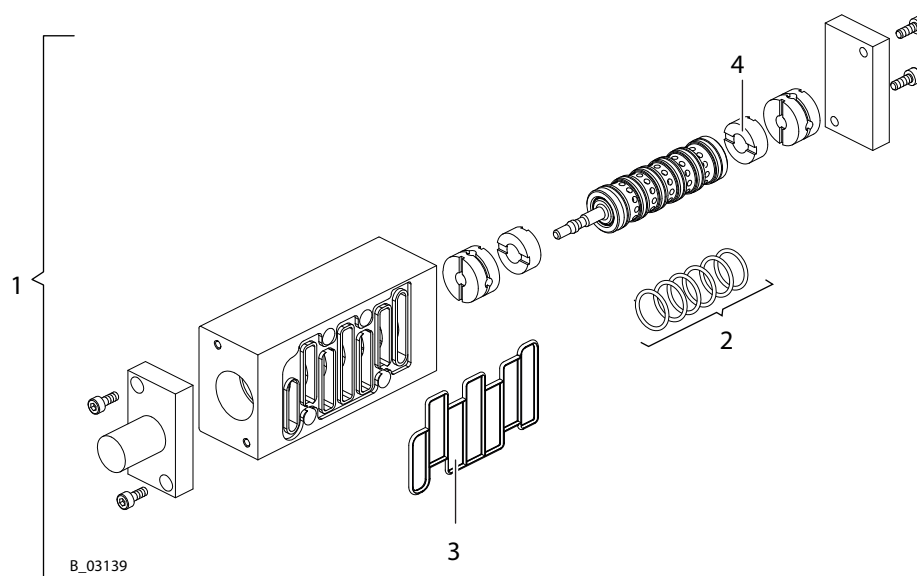

Pos	K	Stk	Order no.	Designation
1		1	P498.00	Reversing Valve
2		6	9971123	O-ring
3		1	P521.00	Reversing valve seal
4		2	P520.00	Damper

14.7 FLUID SECTION 60

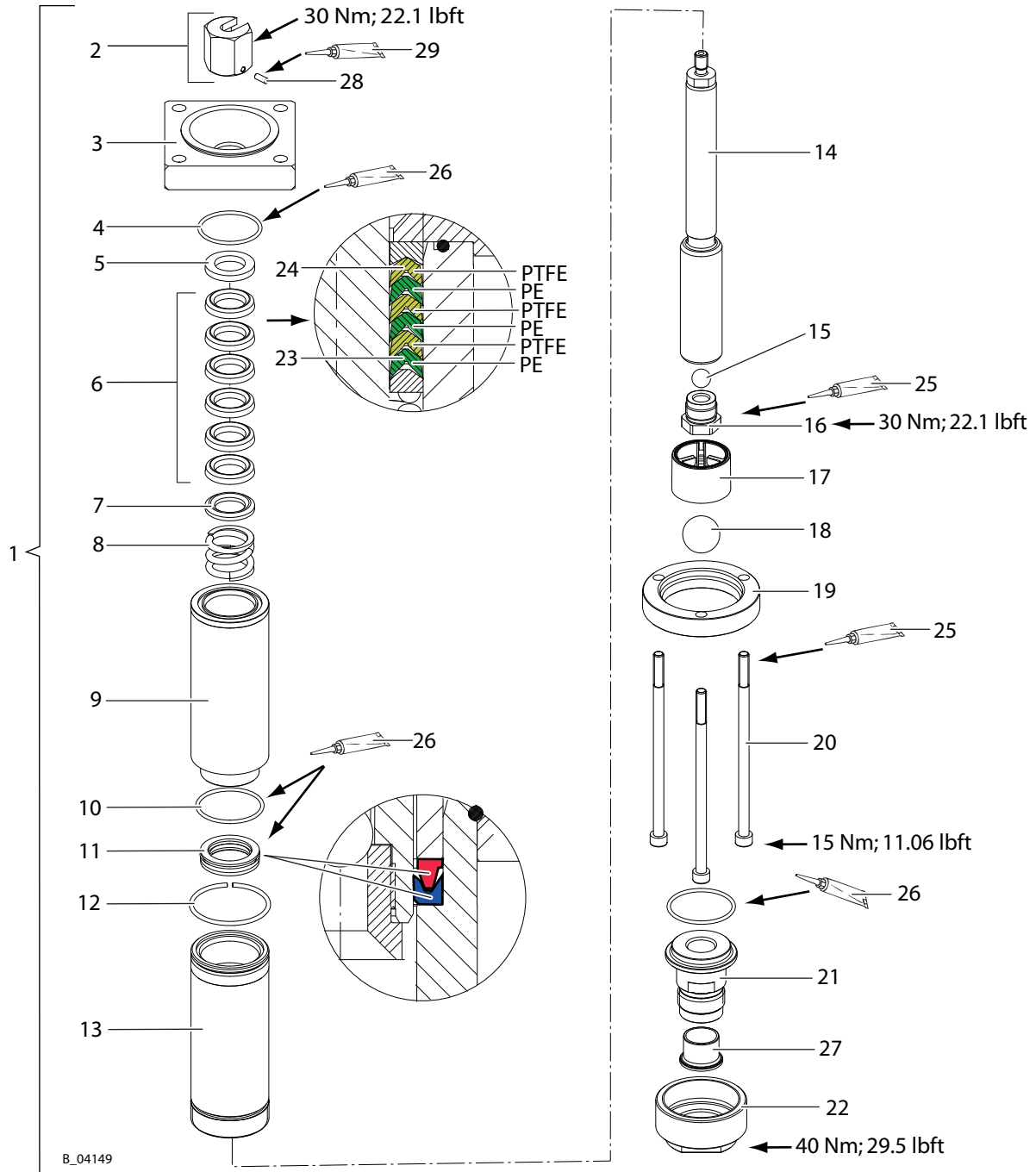

Pos	K	Stk	Order no.	Designation
1		1	2329681	Fluid section 60 PE/T EM
2		1	T6158.00	Connector
3		1	B0448.62	Pump flange, upper
4	◆*	1	L237.05	O-ring
5		1	A150.03A	Support ring
6	◆*	1	T9040.00	Packing, upper

Pos	K	Stk	Order no.	Designation
7		1	A151.03A	Pressure ring
8		1	H210.03	Spring, upper
9		1	B0449.03	Pump housing, upper
10	◆*	2	L228.05	O-ring
11	◆*	1	L484.05	Piston seal
12		1	K643.02	Round wire snap ring for shafts
13		1	B0450.03	Cylinder tube, lower
14	◆	1	D223.53	Piston 60
15	◆	1	K802.03	Ball
16	◆	1	B0451.03	Valve rod housing
17	◆*	1	368507	Ball guide, inlet
18	◆	1	K814.03	Ball
19		1	B0453.62	Pump flange, lower
20		3	K1083.62	Hexagon socket head cap screw
21	◆	1	2324434	Inlet fitting
22		1	B0454.62	Pump housing, lower
23		3	G124.08E	PE seal
24		3	G124.05	PTFE seal
25		1	9992831	Loctite® 542
26		1	9998808	Mobilux® EP 2 grease
27		1	2329072	Sealing sleeve
28		1	2394356	Grub screw with hexalobular socket
29		1	9992590	Loctite® 222
	●	1	T9097.00	EM 60 fluid section service set

◆ = wearing parts

* = Included in service set

● = Not part of the standard equipment but available as an accessory.

15 DECLARATION OF CONFORMITY

15.1 EU DECLARATION OF CONFORMITY

We hereby declare that the supplied version of the pneumatic piston pumps and their spray packs:

EvoMotion 5-60

complies with the following guidelines:

2006/42/EC
2014/34/EU (ATEX Directive)

Applied standards, in particular:

DIN EN ISO 12100:2010	EN 14462:2015
EN 809: 1998+A1:2009+AC:2010	EN 12621:2006+A1:2010
EN ISO 4413:2010	EN 1127-1:2011
EN ISO 4414:2010	EN ISO 80079-36:2016
EN ISO 13732-1:2008	EN ISO 80079-37:2016

Applied national technical standards and specifications, in particular:

DGUV regulation 100-500 Chapter 2.29
DGUV regulation 100-500 Chapter 2.36
TRGS 727

Identification:

  II 2 G Ex h IIB T3/T4 Gb X

EU Declaration of Conformity

The EU Declaration of Conformity is enclosed with this product. If needed, further copies can be ordered through your WAGNER dealer by specifying the product name and serial number.

Order number:

2312813







CET

DISTRIBUTED BY COATING EQUIPMENT TECHNOLOGY, INC
store.cetinc.com • (586) 210-0555

WAGNER



Order number 2333563
Edition 10/2020

Germany

J. Wagner GmbH
Otto-Lilienthal-Strasse 18
Postfach 1120
D-88677 Markdorf
Telephone: +49 (0)7544 5050
Fax: +49 (0)7544 505200
E-mail: ts-liquid@wagner-group.com

Switzerland

Wagner International AG
Industriestrasse 22
CH-9450 Altstätten
Telephone: +41 (0)71 757 2211
Fax: +41 (0)71 757 2222

Document number 11151176
Version D



More contact addresses on the internet at:
www.wagner-group.com

Subject to changes without notice