



Translation of the Original Operating Manual

For professional use.
Always follow the information in this manual,
particularly the safety instructions and the warning
instructions. Store the manual in a safe place.

Version 02/2018

AquaCoat 5010 / 5020

GM 5020EAW

Low Pressure
Manual

Air Spraying System
for Non-ignitable Liquids

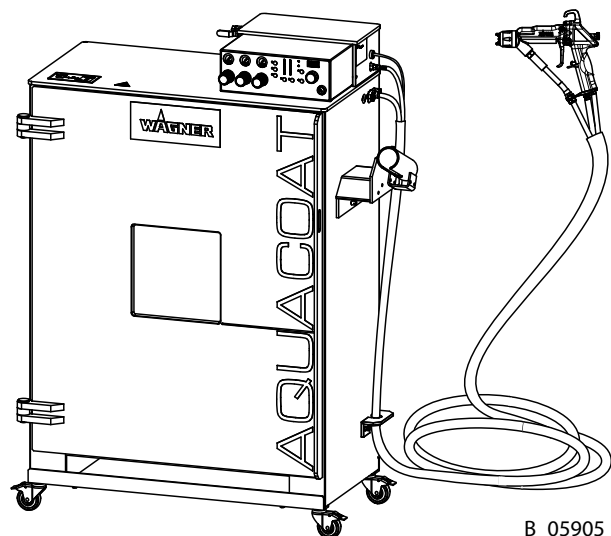

B_05905

CE

Table of Contents

1	ABOUT THESE INSTRUCTIONS	7
1.1	Preface	7
1.2	Warnings, Notices and Symbols in these Instructions	7
1.3	Languages	8
1.3.1	Operating Manuals for the Individual Components	8
1.4	Abbreviations	8
1.5	Terminology for the Purpose of this Manual	9
2	CORRECT USE	10
2.1	Device Type	10
2.2	Type of Use	10
2.3	Field of Application	10
2.4	Processible Working Materials	11
2.5	Misuse	11
3	IDENTIFICATION	12
3.1	CE Identification	12
3.2	Type Plates	12
3.3	Safety Signage	13
4	BASIC SAFETY INSTRUCTIONS	14
4.1	Safety Instructions for the Operator	14
4.1.1	Electrical Devices and Equipment	14
4.1.2	A Safe Work Environment	14
4.1.3	Personnel Qualifications	15
4.2	Safety Instructions for Staff	15
4.2.1	Personal Safety Equipment	15
4.2.2	Safe Handling of WAGNER Spray Devices	16
4.2.3	Ground the Unit	16
4.2.4	Product Hoses	17
4.2.5	Cleaning and Flushing	18
4.2.6	Touching Hot Surfaces	19
4.2.7	Maintenance and Repair	19
4.2.8	Protective and Monitoring Equipment	19
4.2.9	Safety-relevant Information about Discharges	19
5	DESCRIPTION	20
5.1	Components	20
5.2	Mode of Operation	24
5.3	Protective and Monitoring Equipment	24
5.4	Included Items	26
5.4.1	Basic Sets	27
5.5	Technical Data	28
5.5.1	AquaCoat 5010/5020 Entire System	28
5.5.2	Product Pressure Generator	29
5.5.3	VM 5020W Control Unit	30
5.5.4	GM 5020EAW Spray Gun	31
5.5.5	AquaCoat Electric Block Diagram	32

5.6	Operating Elements	33
5.6.1	VM 5020W Control Unit	33
5.6.2	Product Pressure Generator	37
5.7	GM 5020EAW Spray Gun	38
5.7.1	Components	38
5.7.2	Mode of Operation	39
5.7.3	Spraying Procedure for Round Jet Air Atomizing	41
5.7.4	Spraying Procedure for Flat Jet Air Atomizing	42
5.7.5	The Electrostatic Effect	42
6	ASSEMBLY AND COMMISSIONING	43
6.1	Training of Assembly/Commissioning Staff	43
6.2	Storage and Installation Conditions	43
6.3	Transportation	43
6.4	Assembly and Installation	44
6.4.1	Assembling the AquaCoat System	44
6.4.2	Ventilation of the Spray Booth	46
6.4.3	Pneumatic Connections	46
6.4.4	Product Connections	46
6.5	Grounding	47
6.6	Safety Checks	48
6.7	Preparation of Water-based Lacquer	49
6.7.1	Viscosity Conversion Table	49
6.8	Commissioning	50
6.8.1	Preparation	50
6.8.2	Commissioning	50
6.8.3	Verifying a Safe Operational Condition	51
7	OPERATION	52
7.1	Training the Operating Staff	52
7.2	Electrical Discharge	52
7.3	Emergency Deactivation	53
7.4	Working	54
7.4.1	Checking the Spray Pattern (Without Electrostatics)	54
7.4.2	Starting the System	56
7.4.3	Spraying	57
7.4.4	Pressure Relief/Work Interruption	58
7.4.5	Changing the Nozzle, Changing from Round Jet/Flat Jet	58
7.4.6	Cleaning of the Nozzle Parts	59
7.4.7	Starting up the VM 5020W Control Unit	60
7.4.8	Set and Save Recipes	60
7.4.9	Setting the High Voltage	61
7.4.10	Setting the Current Limitation	62
7.4.11	Display during Spraying Mode	63
7.4.12	Standby Mode	63
7.4.13	Operating Hours Counter/Service Display	64
7.5	Device Configuration	66
7.5.1	Overview of Parameters	66
7.5.2	Access to the Device Configuration Mode	67
7.5.3	Setting Example: "Parameter C13"	69
7.6	External Interface	70

8	CLEANING AND MAINTENANCE	72
8.1	Cleaning	72
8.1.1	Cleaning Staff	72
8.1.2	Safety Instructions	72
8.1.3	Flushing and Cleaning the System	73
8.1.4	Decommissioning	74
8.1.5	Long-term Storage	74
8.2	Maintenance	75
8.2.1	Maintenance Staff	75
8.2.2	Safety Instructions	75
8.2.3	Safety Checks and Maintenance Intervals	76
8.2.4	Changing the Spray Gun With Hose Set	77
8.2.5	Replacing the Product Hose and/or Air Hose	78
8.2.6	Product Hoses, Tubes and Couplings	78
9	TROUBLESHOOTING	79
9.1	Fault Displays at the VM 5020W Control Unit	79
9.2	Faults in the System	81
10	REPAIRS	82
10.1	Repair Staff	82
10.2	Safety Instructions	82
10.3	Mounting Materials	83
10.4	Spray Gun	83
10.4.1	Tools	83
10.4.2	Dismantling of the Spray Gun	84
10.4.3	Cleaning the Parts after Disassembly	87
10.4.4	Assembling the Spray Gun	88
10.5	Disassembling VM 5020W Control Unit	93
10.6	Opening the Control Unit	93
11	FUNCTION TEST AFTER THE REPAIR	94
11.1	Function Tests for Spray Gun	95
11.1.1	Air Tests	95
11.1.2	Product Pressure Test	96
11.1.3	Check Spray Pattern	96
12	DISPOSAL	97
13	ACCESSORIES	98
13.1	Valve Seats/Valve Tips	98
13.2	Round Spray Nozzles	98
13.2.1	Adjustable EAWRV 5000 Round Jet Nozzle	98
13.2.2	AWR 5000 Air Caps and Nozzles	98
13.2.3	Discharge Quantity Measurements with Lacquer	99
13.3	Flat Jet Nozzles	100
13.3.1	AF 5000 Air Caps	100
13.3.2	AF 5000 Flat Jet Nozzles	100
13.3.3	Discharge Quantity Measurements with Lacquer	101
13.4	Hoses and Cables	102
13.5	Product Pressure Regulator for DD10	103
13.6	Miscellaneous	104

14	SPARE PARTS	106
14.1	How can Spare Parts be Ordered?	106
14.2	AquaCoat Basic Device	107
14.2.1	VM 5020W Control unit	112
14.3	Pump Sets	118
14.3.1	DD10 Set	118
14.3.2	DD10 Set with Product Pressure Regulator	119
14.3.3	ZIP52 Set	120
14.4	GM 5020EAW Spray Gun	122
14.4.1	GM 5000EA Adapter	124
14.4.2	ES 5000 Air Handle	126
14.5	Accessories Spare Parts Lists	127
14.5.1	AWR 5000 Round Jet Nozzles	127
14.5.2	Adjustable EAWRV 5000 Round Jet Nozzles	128
14.5.3	Underframe with Rolls	129
14.5.4	Hose Holder	130
14.5.5	Gun Holder	130
14.5.6	Level Monitoring with Alarm Horn	131
14.5.7	D350 Drum Cover	132
15	DECLARATION OF WARRANTY AND CONFORMITY	133
15.1	Important Notes on Product Liability	133
15.2	Warranty Claim	133
15.3	EC Declaration of Conformity	134

1 ABOUT THESE INSTRUCTIONS

1.1 PREFACE





The operating manual contains information about safely operating, maintaining, cleaning and repairing the device. The operating manual is part of the device and must be available to the operating and service personnel.

The device may only be operated by trained personnel and in compliance with this operating manual. Operating and service personnel should be instructed according to the safety instructions.

This equipment can be dangerous if it is not operated according to the instructions in this operating manual.

1.2 WARNINGS, NOTICES AND SYMBOLS IN THESE INSTRUCTIONS

Warning instructions in this operating manual highlight particular dangers to users and to the device and state measures for avoiding the hazard. These warning instructions fall into the following categories:

 DANGER	Immediate risk of danger. Non-observance will result in death or serious injury.
 WARNING	Potential risk. Non-observance may result in death or serious injury.
 CAUTION	Potentially hazardous situation. Non-observance may result in minor injury.
 NOTICE	Potentially hazardous situation. Non-observance may result in damage to property.
Notice	Provides information about particular characteristics and how to proceed.

Explanation of warning:

LEVEL OF DANGER

This notice warns you of a hazard!

Possible consequences of not observing the warning instructions.

→ The measures for preventing the hazard and its consequences.



1.3 LANGUAGES

The **AquaCoat GM 5020EAW** operating manual is available in the following languages:

Language	Order No.	Language	Order No.	Language	Order No.
German	2363957	English	2366717	Spanish	2366716
French	2366718	Italian	2366719	--	--

Additional languages on request or at: www.wagner-group.com

1.3.1 OPERATING MANUALS FOR THE INDIVIDUAL COMPONENTS

Double diaphragm pump **TOPFINISH DD10** operating manual

Language	Order No.	Language	Order No.	Language	Order No.
German	2366669	English	2366672	Spanish	2369232
French	2369230	Italian	2369231	--	--

Double diaphragm pump **ZIP52 GHSS7** operating manual

Language	Order No.	Language	Order No.	Language	Order No.
German	2330425	English	2330426	Spanish	2335555
French	2335553	Italian	2332230	--	--

Product pressure regulator **T0170.00BI** operating manual

Language	Order No.	Language	Order No.	Language	Order No.
German	ZZB019GER	English	ZZB019ENG	Spanish	ZZB019SPA
French	ZZB019FRE	Italian	ZZB019ITA	--	--

Additional languages on request or at: www.wagner-group.com

1.4 ABBREVIATIONS

Order No.	Order number
ET	Spare part
Pos	Position
K	Marking in the spare parts lists
Stk	Number of pieces
EAW	Air electrostatic, water-based
GM	Manual gun
HS	High voltage
HD	High pressure

SW	Wrench size
LV	Low viscosity
HV	High viscosity

Materials

SSt	Stainless steel
PEEK	Polyether ether ketone (high temperature-resistant thermoplastic plastic)

1.5 TERMINOLOGY FOR THE PURPOSE OF THIS MANUAL

Cleaning	Manual cleaning of devices and device parts with cleaning agent.
Flushing	Internal flushing of paint-wetted parts with flushing agent.

Staff qualifications

Trained person	Is instructed in the tasks assigned to him/her, the potential risks associated with improper behavior as well as the necessary protective devices and measures.
Electrically trained person	Is instructed by an electrician about the tasks assigned to him/her, the potential risks associated with improper behavior as well as the necessary protective devices and measures.
Electrician	Can assess the work assigned to him/her and detect possible hazards based on his/her technical training, knowledge and experience in relevant provisions.
Skilled person in the context of DGUV 209-052	A person who, based on his/her technical training, experience and recent vocational experience, has sufficient technical knowledge in the area of electrostatic coating and is familiar with the relevant and generally accepted rules of technology so that he/she can inspect and assess the status of devices and coating systems based on workplace safety. → Additional requirements for skilled persons can also be found in TRBS 1203 (2010/amendment 2012): Expert knowledge in the areas of protection against excessive pressure, electrical hazards, and explosion protection (where applicable).

2 CORRECT USE

2.1 DEVICE TYPE

Electrostatic spraying unit for manual coating of grounded work pieces. The system is suitable for air-atomizing applications.

The system is equipped with the AquaCoat 5010/5020 cabinet, the VM 5020W control unit, a GM 5020EAW spray gun and matching hose set, a high-voltage generator, all safety devices and one of the following spray product supplies:

- Double diaphragm pump, TOPFINISH DD10 (in accordance with the spare parts catalog)
- Double diaphragm pump, ZIP52 GHSS7 (in accordance with the spare parts catalog)

2.2 TYPE OF USE

AquaCoat 5010/5020 GM 5020EAW can be used to spray liquid, non-ignitable products, in particular non-ignitable coating products in accordance with Chapter [2.4](#).

WAGNER explicitly prohibits any other use!

The device may only be operated under the following conditions:

- Use the device only to work with the products recommended by WAGNER.
- Do not deactivate safety fixtures.
- Use only WAGNER original spare parts and accessories.
- The operating personnel must be trained on the basis of this operating manual.

- Follow the instructions in the operating manual.

2.3 FIELD OF APPLICATION

The device is **not** suitable for use in potentially explosive areas.
(See Chapter [3.1](#) "CE Identification".)

2.4 PROCESSIBLE WORKING MATERIALS

Water-dilutable lacquers are in principle divided into 3 groups:

→ **Non-ignitable lacquers**

Hard to ignite lacquers
Ignitable lacquers

Only non-ignitable liquid spray products can be processed with the present spray system. The specific resistance of the spray product must be between 0.5 kΩ cm and 1 MΩ cm.

Assign group

Basically, the lacquer manufacturer determines in which group a spray product is to be classified.

1. Request the group classification from the lacquer manufacturer or lacquer supplier.
2. Only if no information can be obtained from the lacquer manufacturer and the lacquer supplier, the following recipe can be used to determine whether the spray product is non-ignitable:

$$\text{Gew. \% H}_2\text{O} > \frac{63}{37} \times \text{Gew. \% LM} + \frac{49}{51} \times \text{Gew. \% ORG}$$

Where:

Gew. % Weight percent

H₂O Water

LM Liquid organic phase; main components: Higher glycol esters in a mixture with max. 1:1 of propanol.

ORG Solid organic phase; main components: Binding agents and pigments.

Such lacquers behave like water in liquid form (liquid phase) and in sprayed form.

Cleaning and flushing agents

→ Cleaning and flushing agents must also align with this category.

Example of non-ignitable liquid:

No more than 35 weight percent, 1:1 butylglycol/n-propanol, rest water.

Please contact your local WAGNER dealer and the paint manufacturer if you encounter application problems.

2.5 MISUSE

Misuse can lead to physical injury and/or property damage!

Special attention must be paid that:

- No dry coating products, e.g., powder are processed.
- No food, medicine or cosmetics are processed.

3 IDENTIFICATION



3.1 CE IDENTIFICATION

The device may **not** be used in potentially explosive areas.



3.2 TYPE PLATES



AquaCoat cabinet

		Wagner International AG		
		Industriestrasse 22 CH-9450 ALTSTÄTTEN MADE IN SWITZERLAND		
1	Gerätetyp / Type:	AquaCoat 5010/5020 Manual		
2	Eingangsspannung / Voltage input	115 - 230VAC, 50Hz / 60Hz		
3	Eingangsleistung / Power input	max. 40 W		
4	Ausgangshochspannung / High voltage output	max. 70 kV DC		
5	Ausgangsstrom / Current output	max. 100 µA DC		
6	Norm / Standard	EN 50059		
7	Luftdruck max. / Air pressure max.	0.8 MPa, 116 psi		
8	Temperatur Material max. / Fluid temp. max.	+50°C, +122°F		
9	Temperatur Umgebung / Temperatur area	+5 / +40°C, +41 / +104°F		
10	Baujahr - Serie Nr. / Year of manufacture - Serial No.	<input type="text"/>		
11	Vor Gebrauch Betriebsanleitung beachten / Check manual before use!			

B_06766

Pos	Designation
1	Device type
2	Input voltage
3	Input power
4	Output high voltage
5	Output current
6	Standard
7	Maximum air pressure
8	Maximum product temperature
9	Ambient temperature
10	Year of manufacture – serial number
11	Read operating manual before use!

VM 5000W control unit

9	Spannung: max. 20Vpp		
	Voltage: max. 20Vpp		
10	Strom: max. 1,0A	Wagner International AG	
	Current: max. 1,0A	Industriestrasse 22 CH - 9450 Altstätten Made in Switzerland	
1	Typ / Type:	VM 5020W	
2	Artikel Nr. / Article No.:	2360060	
3	Baujahr: Year of manufacture:		
4	Serie Nr. / Serial No.:		
5	Spannung: Voltage:	115 - 230VAC 50Hz / 60Hz	
6	Eingangsleistung: Line Power:	max. 40W	
7	Schutzart: IP Code:	IP 40	
8	Norm: Standard:	EN 50059	

B 06755

Pos	Designation
1	Type
2	Article number
3	Year of manufacture
4	Serial number
5	Input voltage
6	Maximum input power
7	Protection class
8	Standard
9	Maximum output voltage
10	Maximum output current

OPERATING MANUAL



GM 5020EAW spray Gun

B_05876

WAGNER
Wagner International AG

1 GM 5020EAW
2 Art. Nr.: 2362847
3 max. high voltage: 70kV / 350mJ
4 max. mat. pressure: 0.8MPa; 8bar; 116psi
5 max. air pressure: 0.8MPa, 8bar; 116psi

Pos	Designation
1	Gun type
2	Article number
3	Maximum high voltage / Energy
4	Maximum product pressure
5	Maximum air pressure
6	In compliance with EN 50059
7	For electrostatic application of water-based lacquers

B_05875

CE

geprüft nach EN 50059 **6**

For Waterborne Electrostatic Finishing Applications **7**

Serial number

The serial number (S) on the underside of the handle.

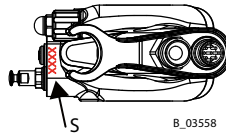

3.3 SAFETY SIGNAGE

AquaCoat cabinet	GM 5020EAW spray gun	GM 5020EAW spray gun VM 5020W control unit
Warning: Hazardous voltage	Warning: Danger of becoming injured by high-pressure jet	Do not dispose of used electrical equipment with household refuse. → see Chapter 12

AquaCoat cabinet

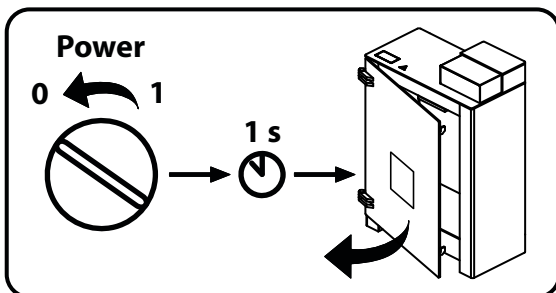

Door lock

One second after the control unit has been switched off, the system is grounded and the door lock opened.

B_05871

4 BASIC SAFETY INSTRUCTIONS

4.1 SAFETY INSTRUCTIONS FOR THE OPERATOR

- Keep this operating manual at hand near the device at all times.
- Always follow local regulations concerning occupational safety and accident prevention.



4.1.1 ELECTRICAL DEVICES AND EQUIPMENT

Electric shock hazard!

Danger to life from electric shock

- Prepare device in accordance with the local safety requirements with regard to the operating mode and ambient influences.
- May only be maintained by skilled electricians or under their supervision. With open housings, there is a danger from line voltage.
- Operate device in accordance with the safety regulations and electrotechnical regulations.
- Must be repaired immediately in the event of problems.
- Decommission if it poses a hazard or is damaged.
- Must be de-energized before work is commenced. Inform staff about planned work. Observe electrical safety regulations.
- Ground all devices to a common grounding point.
- Only operate the device with a properly installed socket with a protective ground wire connection.
- Keep liquids away from electrical devices.



4.1.2 A SAFE WORK ENVIRONMENT

Hazard due to dangerous fluids or steam!

Severe or fatal injuries due to explosion hazard or inhalation, swallowing or contact with the skin or eyes.

- Ensure that the floor in the working area is static dissipative in accordance with EN 61340-4-1 (resistance must not exceed 100 MΩ).
- Paint mist extraction systems/ventilation systems must be fitted on site according to local regulations.
- Make sure that the ground connection and potential equalization of all system parts are reliable and continuous and can withstand the expected stress (e.g. mechanical stress, corrosion).
- Ensure that product / air hoses adapted to the working pressure are used.
- Ensure that personal protective equipment (see Chapter 4.2.1) is available and is used.
- Ensure that all persons within the working area wear static dissipative shoes. Footwear must comply with EN 20344. The measured insulation resistance must not exceed 100 MΩ.
- Ensure that during spraying, persons wear electrically conductive gloves. The grounding takes place via the spray gun handle or the trigger.
- Protective clothing, including gloves, must comply with EN 1149-5. The measured insulation resistance must not exceed 100 MΩ.



- Ensure that there are no ignition sources such as naked flames, sparks, glowing wires, or hot surfaces in the vicinity. No smoking.
- Ensure that the pipe joints, hoses, equipment parts and connections are permanently, technically leak-proof:
 - Periodic preventative maintenance and service (replacing hoses, checking tightness strength and connections, etc.)
 - Regular monitoring of leaks and defects via visual inspection and odor testing, e.g., daily before commissioning, at the end of work or weekly.
- In the event of defects, immediately bring the device or system to a stop and arrange to have repairs carried out immediately.

4.1.3 PERSONNEL QUALIFICATIONS

Hazard due to incorrect use of device!

Risk of death due to untrained personnel.

- Ensure that the operating personnel has been instructed by the operator in accordance with the operating manual and the operating instructions. The device must only be operated, maintained and repaired by trained personnel. Refer to the operating instructions for information about the required personnel qualifications.

4.2 SAFETY INSTRUCTIONS FOR STAFF

- Always follow the information in this manual, particularly the safety instructions and the warning instructions.
- Always follow local regulations concerning occupational safety and accident prevention.



Hazard due to high-voltage field!

Danger to life from malfunction of active implants.

- Persons belonging to a risk group according to EMF guideline 2013/35/EU (e.g., carriers of active implants), must not enter the high-voltage area.



4.2.1 PERSONAL SAFETY EQUIPMENT

Hazard due to dangerous fluids or steam!

Serious or fatal injuries due to inhalation, swallowing or contact with the skin or eyes.

- When preparing or working with paint and when cleaning the device, follow the working instructions of the manufacturer of the lacquers, solvents, and cleaning agents being used.
- Take the specified protective measures. In particular wear safety goggles, protective clothing and gloves, as well as hand protection cream if necessary.
- Use a mask or breathing apparatus if necessary.
- For sufficient health and environmental safety: Operate the device in a spray booth or on a spraying wall with the ventilation (extraction) switched on.
- Wear suitable protective clothing when working with hot products.



4.2.2 SAFE HANDLING OF WAGNER SPRAY DEVICES

Hazard due to injection of lacquer or flushing agent into the skin!

The spray jet is under pressure and can cause dangerous injuries. Avoid injection of paint or flushing agents:

- Never point the spray gun at people.
- Never reach into the spray jet.
- Before any work on the device, in the event of work interruptions and malfunctions:
 - Switch off the energy/compressed air supply.
 - Relieve the pressure from the spray gun and unit.
 - Secure the spray gun against actuation.
 - Disconnect the control unit from the mains.
 - In the event of functional faults: remedy the fault as described in the "Troubleshooting" chapter.
- If needed, the liquid ejection devices must be checked by experts (e.g., WAGNER service technician) at least every 12 months for their work-safe condition in accordance with DGUV regulation 100-500 Chapter 2.29 and Chapter 2.36.
 - For shut down devices, the examination can be suspended until the next start-up.



In the event of skin injuries caused by lacquer or flushing agents:

- Note the lacquer or flushing agent that you have been using.
- Consult a doctor immediately.

Danger due to recoil forces!

Actuating the trigger can cause strong recoil forces. Thereby the user can lose his balance and injure himself during falling.

Avoid risk of injury from recoil forces:

- Ensure that you have firm footing when operating the spray gun.



4.2.3 GROUND THE UNIT

Hazard due to electrostatic charge!

Risk of injury, explosion hazard and damage to the device.

Friction, flowing liquids and air or electrostatic coating processes create charges. Flames or sparks can form during discharge.

Correct grounding of the entire spraying system prevents electrostatic charges.

- Ensure that all devices and tanks are grounded before each spraying process.
- Make sure that the ground and potential equalization of all system parts are performed reliably and continuously and can withstand the expected stress (e.g., mechanical stress, corrosion).
- Ground the work pieces to be coated.
- Ensure that all persons inside the working area are grounded, e.g., that they are wearing static dissipative shoes.
- Wear static dissipative gloves when spraying. The grounding takes place via the spray gun handle or the trigger.

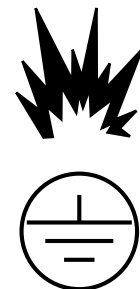

4.2.4 PRODUCT HOSES

Hazard due to bursting of product hose!

The product hose is under pressure and may cause dangerous injuries.

- Ensure that the hose material is chemically resistant to the sprayed products and the flushing agents used.
- Ensure that the product hoses and the fittings are suitable for the pressure generated.
- Ensure that the following information can be seen on the high-pressure hose:
 - Manufacturer
 - Permissible operating pressure
 - Date of manufacture
- Make sure that the hoses are laid only in suitable places. Hoses should not be laid in the following places under any circumstances:
 - in high traffic areas,
 - on sharp edges,
 - on moving parts or
 - on hot surfaces.
- Ensure that the hoses are never run over by vehicles (e.g., fork lifts), or that the hoses are never put under pressure from the outside in any other way.
- Ensure that the hoses are never kinked. Observe maximum bending radii.
- Ensure that no work is ever performed with a damaged hose.
- Make sure that the hoses are never used to pull or move the equipment.
- The electrical resistance of the product hose, measured at both valves, must be less than 1 MΩ.
- Suction hoses may not be subjected to pressure.

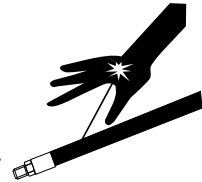

Several liquids have a high expansion coefficient. In some cases their volume can rise with consequent damage to pipes, fittings, etc. and cause fluid leakage.

When the pump sucks liquid from a closed tank, ensure that air or a suitable gas can enter the tank. Thus a negative pressure is avoided. The vacuum could implode the tank (squeeze) and can cause it to break. The tank would leak and the liquid would flow out.

The pressure created by the pump is a multiplication of the inlet air pressure.

4.2.5 CLEANING AND FLUSHING

Hazard due to cleaning and flushing!

Explosion hazard and damage to the device.

- Preference should be given to non-ignitable cleaning and flushing agents.
- When carrying out cleaning work with flammable cleaning agents, make sure that all equipment and resources (e.g., collection tank, funnel, transport cart) are conductive or static dissipative and grounded.
- Observe the specifications of the lacquer manufacturer.
- Ensure that the flash point of the cleaning agent is at least 15 K above the ambient temperature or that cleaning is undertaken at a cleaning station with technical ventilation.
- Never use chloride or halogenated solvents (such as trichloroethane and methylene chloride) with units containing aluminium or galvanized and zinc-plated parts. They may react chemically thus producing an explosion danger.
- Take measures for workplace safety (see Chapter [4.1.2](#)).
- When commissioning or emptying the device, please note that an explosive mixture may temporarily exist inside the lines and components of equipment:
 - Depending upon used coating product,
 - depending on the flushing agent (solvent) used,
 an explosive mixture may temporarily exist inside the lines and items of equipment.
- Only electrically conductive tanks may be used for cleaning and flushing agents.
- The tanks must be grounded.



An explosive gas/air mixture forms in closed tanks.

- Never spray into a closed tank when using solvents for flushing.

External cleaning

When cleaning the exterior of the device or its parts, also observe the following:

- Relieve the pressure from the device.
- De-energize the device electrically.
- Disconnect the pneumatic supply line.
- Use only moistened cloths and brushes. Never use abrasive agents or hard objects and never spray cleaning agents with a gun. Cleaning the device must not damage it in any way.
- Ensure that no electric component is cleaned with or immersed into solvent.
- Which cleaning agent is used to clean the spray gun depends on which parts of the spray gun have to be cleaned and which product has to be removed. When cleaning the spray gun, only use **non-polar cleaning agents** to prevent conductive residues on the surface of the spray gun. Should it however, be necessary to use a polar cleaning agent, all residues of this cleaning agent have to be removed by using a non-conductive and non-polar cleaning agent, once the cleaning is finished.

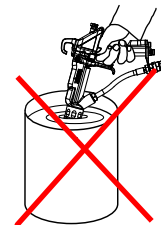

4.2.6 TOUCHING HOT SURFACES

Hazard due to hot surfaces because of hot coating products!

Risk of burn injuries

- Only touch hot surfaces if you are wearing protective gloves.
- When operating the device with a coating product with a temperature of > 43 °C; 109 °F:
 - Identify the device with a warning label, "Warning – Hot surface".

Instruction label: Order no. 9998910

Protection label: Order no. 9998911

Note: Order the two stickers together



4.2.7 MAINTENANCE AND REPAIR

Hazard due to improper maintenance and repair!

Danger to life and equipment damage.

- Only a WAGNER service center or a suitably trained person may carry out repairs and replace parts.
- Do not change or modify the device; if change is necessary, contact WAGNER.
- Only repair and replace parts that are listed in the Chapters [13](#) and [14](#) and that are assigned to the device.
- Do not use any defective components.
- Exclusively use accessories listed in Chapter [13](#) and that are assigned to the unit.
- Before all work on the device and in the event of work interruptions:
 - Switch off the energy and compressed air supply.
 - Relieve the pressure from the spray gun and device.
 - Secure the spray gun against actuation.
- Observe the operating and service manual for all work.

4.2.8 PROTECTIVE AND MONITORING EQUIPMENT

Hazard due to removal of protective and monitoring equipment!

Danger to life and equipment damage.

- Protective and monitoring equipment must not be removed, modified or rendered unusable.
- Regularly check for perfect functioning.
- If defects are detected on protective and monitoring equipment, the system must not be operated until these defects are remedied.

4.2.9 SAFETY-RELEVANT INFORMATION ABOUT DISCHARGES

The plastic parts of the cabinet are charged electrostatically by the high-voltage field. Contact with plastic parts harmless discharges (brush discharges) may occur. They are completely non-hazardous for human health.

5 DESCRIPTION

5.1 COMPONENTS

AquaCoat with TOPFINISH DD10 double diaphragm pump

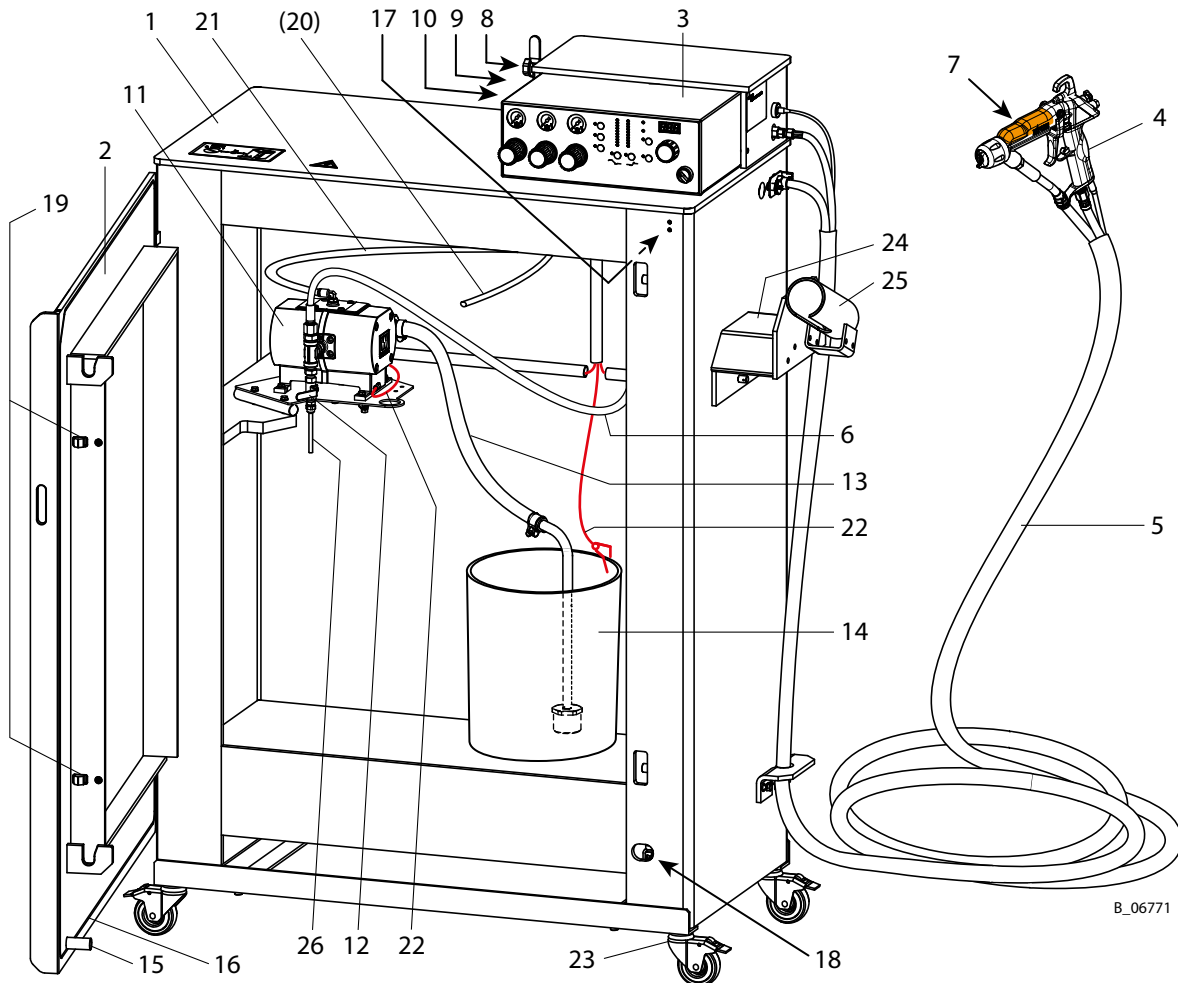

B_06771

Pos	Designation
1	AquaCoat cabinet
2	Cabinet door
3	VM 5020W control unit
4	GM 5020EAW spray gun
5	EAW hose set
6	Product hose to spray gun
7	High-voltage generator (HV cascade)
8	Air inlet with ball valve
9	Inlet for mains cable
10	Grounding terminal (input: grounding cable)
11	Product pressure generator (pump)
12	Relief combination
13	Suction system

Pos	Designation
14	Metallic product tank
15	Grounding bolt on the cabinet door
16	Grounding band in the cabinet door
17	Electrical door switch
18	Pneumatic door switch
19	Door locking device engaging
20	Air hose, 8 mm (not used)
21	Air hose, 10 mm (product pressure generator)
22	Potential equalization lines, orange (4 pieces)
23	Underframe with rolls (special accessory)
24	Hose holder (special accessory)
25	Gun holder (special accessory)
26	Return line



AquaCoat with TOPFINISH DD10 double diaphragm pump and product pressure regulator

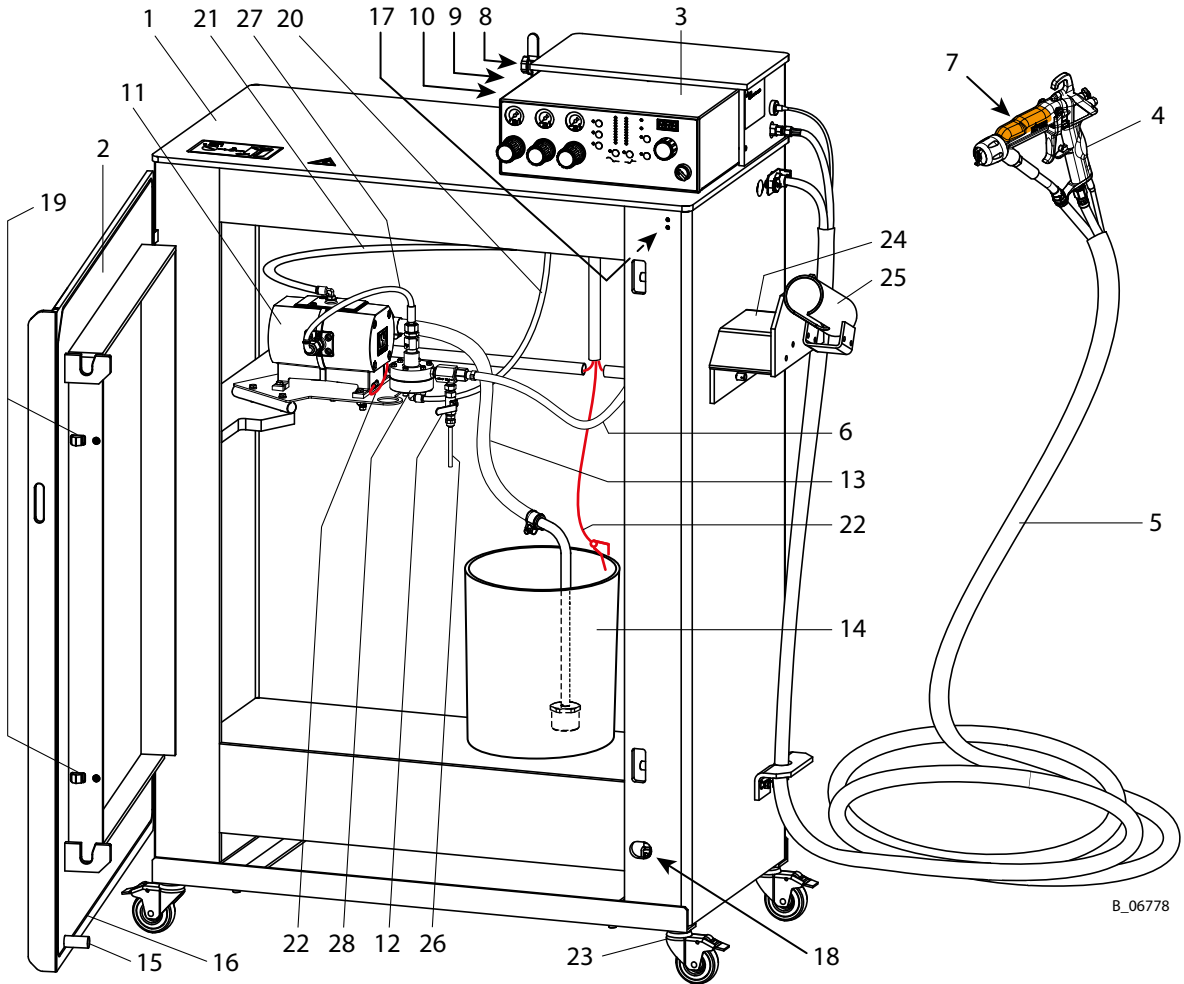

B_06778

Pos	Designation
1	AquaCoat cabinet
2	Cabinet door
3	VM 5020W control unit
4	GM 5020EAW spray gun
5	Hose set EAW
6	Product hose to spray gun
7	High-voltage generator (HV cascade)
8	Air inlet with ball valve
9	Inlet for mains cable
10	Grounding terminal (input: grounding cable)
11	Product pressure generator (pump)
12	Relief combination
13	Suction system
14	Metallic product tank

Pos	Designation
15	Grounding bolt on the cabinet door
16	Grounding band in the cabinet door
17	Electrical door switch
18	Pneumatic door switch
19	Door locking device engaging
20	Air hose, 8 mm (product pressure regulator)
21	Air hose, 10 mm (product pressure generator)
22	Potential equalization lines, orange (4 pieces)
23	Underframe with rolls (special accessory)
24	Hose holder (special accessory)
25	Gun holder (special accessory)
26	Return line
27	Product hose (pump to the product pressure regulator)
28	Product pressure regulator

AquaCoat with ZIP52 double diaphragm pump and product pressure regulator

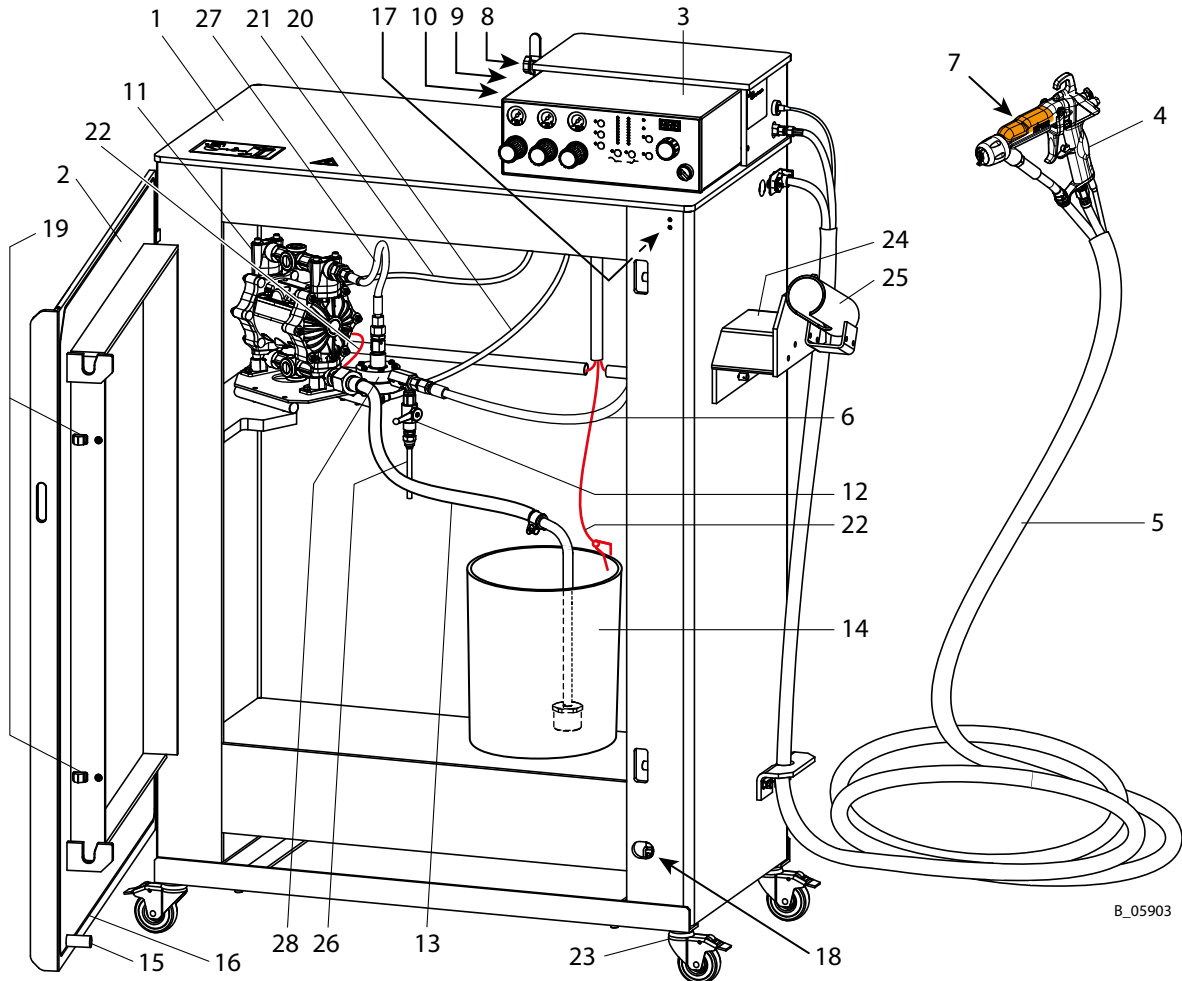

8_05903

Pos	Designation
1	AquaCoat cabinet
2	Cabinet door
3	Control unit, VM 5020W
4	GM 5020EAW spray Gun
5	Hose set EAW
6	Product hose to spray gun
7	High-voltage generator (HV cascade)
8	Air inlet with ball valve
9	Inlet for mains cable
10	Grounding terminal (input: grounding cable)
11	Product pressure generator (pump)
12	Relief combination
13	Suction system
14	Metallic product tank

Pos	Designation
15	Grounding bolt on the cabinet door
16	Grounding band in the cabinet door
17	Electrical door switch
18	Pneumatic door switch
19	Door locking device engaging
20	Air hose, 8 mm (product pressure regulator)
21	Air hose, 10 mm (product pressure generator)
22	Potential equalization lines, orange (4 pieces)
23	Underframe with rolls (special accessory)
24	Hose holder (special accessory)
25	Gun holder (special accessory)
26	Return line
27	Product hose (pump to the product pressure regulator)
28	Product pressure regulator



**AquaCoat cabinet
RH side wall (from the inside)**

Pos	Designation
30	Grounding switch
31	Grounding cylinder
32	Leakage resistance 3 GOhm
33	Potential equalization line connection
34	Passageway for product hose
35	Connection for grounding cable for grounding the conductive sheath of the product hose.
36	Grounding point

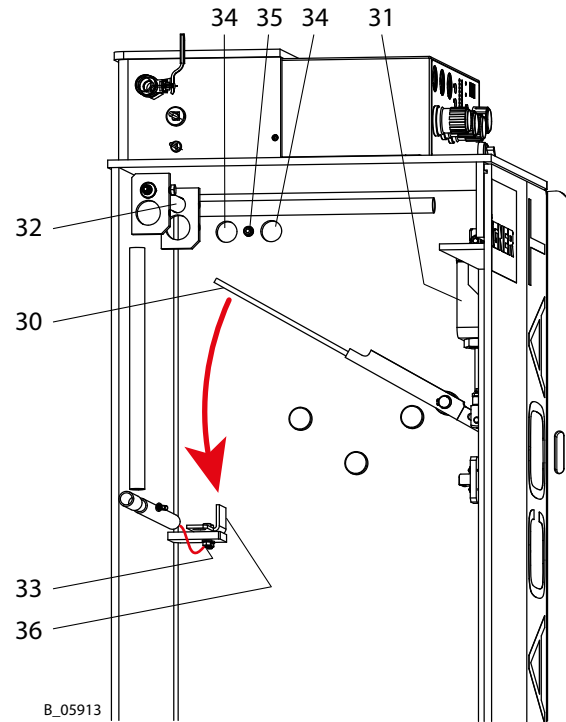

5.2 MODE OF OPERATION

The AquaCoat spray system is designed for processing non-ignitable liquids (water lacquers) in accordance with the air spraying method.

The spray product is regulated via the trigger on the gun (4) and the VM 5020W (3) control unit. It is drawn in with a product pressure generator (11) via a suction system (13), electrostatically charged in the sealed off inner chamber of the AquaCoat cabinet (1), and sprayed in the nozzle of the spray gun with the help of atomizing air.

The product pressure generator and spray gun are connected by the shielded product hose.

5.3 PROTECTIVE AND MONITORING EQUIPMENT

WARNING

Protective and monitoring equipment!

Risk of injury and damage to the device.

- Protective and monitoring equipment must not be removed, modified or rendered unusable.
- Regularly check for perfect functioning.
- If defects are detected on protective and monitoring equipment, the system must not be operated until these defects are remedied.



The following elements are provided for system safety:

Safety element	Function
Grounding switch (30)	Grounding the potential equalization lines and pump support.
Electrical door switch (17)	The grounding switch is closed with an open cabinet door (potential equalization lines are grounded).
Pneumatic door switch (18)	
Leakage resistance (32)	Reduces the high voltage in a controlled manner.
Door lock	Cabinet door can not be opened when the control unit is switched on.
Grounding band (16) in the cabinet door.	The grounding band is grounded over the pneumatic door switch with a closed cabinet door.

Door lock

Only open or close the cabinet door (2) when the control unit (3) is switched off.

One second after the control unit (3) has been switched off, the system is grounded and the door lock opened.

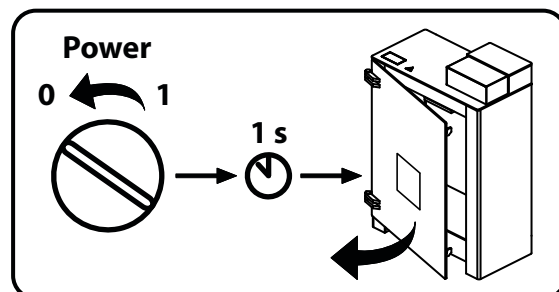

B_05871

AquaCoat cabinet

To achieve an optimal application efficiency, the lacquer supply (lacquer tank and pump) is brought to high-voltage potential in an insulated cabinet. The interior of the cabinet, connected to high voltage, is protected by double (redundant) safety elements before touching. Before the cabinet door can be opened, the system is grounded abruptly by pneumatic grounding switch. A direct discharge of the system to the user is not possible in the area of lacquer supply system. However, the plastic surface of the cabinet can charge, which results in small discharges (brush discharges) when touching the cabinet. These discharges are perceptible but harmless and they are completely non-hazardous for human health.

Product hose

The product hose directs the coating product, which is under high voltage, to the spray gun. The product hose is designed on one hand high voltage resistant and on the other hand, there is the outer shell of the product hose from a conductive, grounded plastic sheath. Even of an electrical breakdown of the product hose, there is no danger to the user, since the current would flow through the grounded sheath.

Manual spray gun

The coating product under high voltage is sprayed on the manual spray gun. If you touch during coating the nozzle area, it results in a system discharge to the grounded user. Such a discharge is weaker, because of the dampening effect of the product hose as a discharge during lacquer supply and according to standard EN 50059 the discharge must not exceed a maximum energy of 350 mJ. Such a discharge can still be fierce and painful, but it is not hazardous to health. Soon as the coating process is interrupted and the trigger is released, the system will be discharged slowly via a discharge resistor of 3 Gohm. This process can take up to 20 seconds, which means that during this period the nozzle area of the spray gun should not be touched. The system is intentionally not abruptly discharged, so that the high voltage does not have to power up from zero again at very short coating intervals.

5.4 INCLUDED ITEMS

AquaCoat basic device	5020	5010	5020G	5010G
Designation	Order No.	Order No.	Order No.	Order No.
AquaCoat basic device: Cabinet including VM 5020W control unit	2363292	2363401	2363734	2363736

The scope of delivery of a basic device includes:

Declaration of Conformity. For details, see Chapter 15.3	2363961
AquaCoat GM 5020EAW operating manual, German	2363957
Operating manual in the local language	see Chapter 1.3

Without window

Example:
AquaCoat 5020

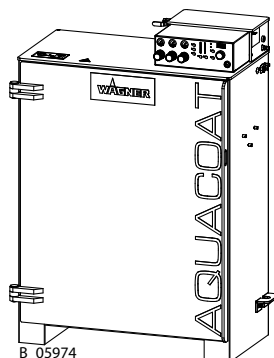

With window (G)

Example:
AquaCoat 5020G

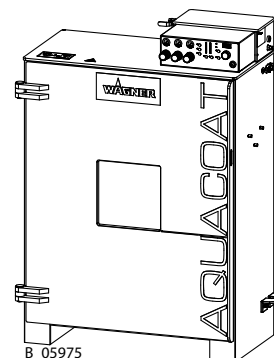

Pump set	DD10	DD10 with product pressure regulator	ZIP52 GHSS7 with product pressure regulator
Designation	Order No.	Order No.	Order No.
Pump set	2364024	2390123	2363856

The scope of delivery of a pump set includes:

Declaration of Conformity for pump	2367686	2367686	2334618
Pump operating manual, German	2366669	2366669	2330425
Operating manual pump in the local language	see Chapter 1.3.1		

GM 5020EAW spray Gun

Designation	Order No.
GM 5020EAW spray Gun	2362852

The scope of delivery of a spray gun includes:

AquaCoat GM 5020EAW operating manual, German	2363957
Operating manual in the local language	see Chapter 1.3.1
CE Declaration of Conformity, AquaCoat	see Chapter 15.3

The delivery note shows the exact scope of delivery.



5.4.1 BASIC SETS

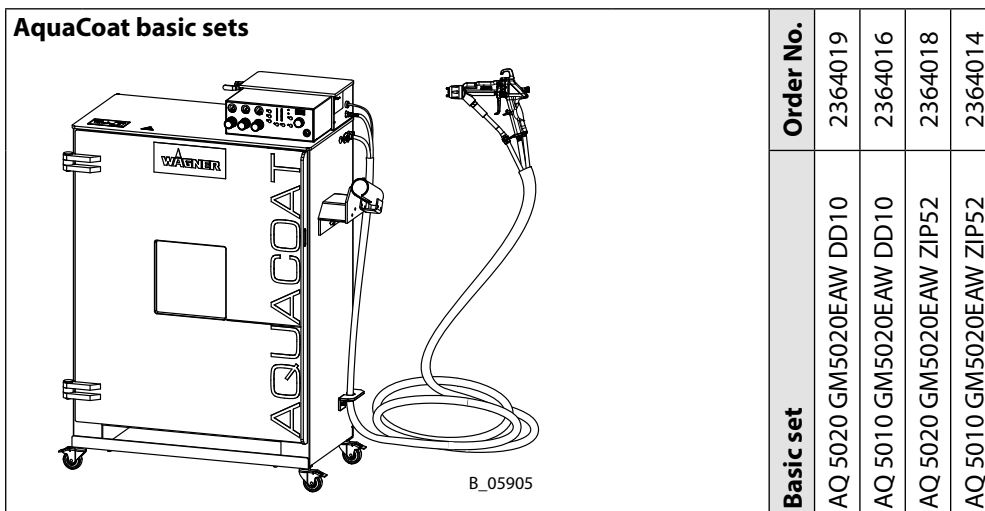

Pos	System component	Order No.
-----	------------------	-----------

AquaCoat cabinet with VM 5020W control unit

Pos	System component	Order No.				
1	AquaCoat 5020 manual basic device	2363292	<input checked="" type="checkbox"/>	<input type="checkbox"/>	<input checked="" type="checkbox"/>	<input type="checkbox"/>
2	AquaCoat 5010 manual basic device	2363401	<input type="checkbox"/>	<input checked="" type="checkbox"/>	<input type="checkbox"/>	<input checked="" type="checkbox"/>
3	AquaCoat 5020G manual basic device	2363734	<input type="checkbox"/>	<input type="checkbox"/>	<input type="checkbox"/>	<input type="checkbox"/>
4	AquaCoat 5010G manual basic device	2363736	<input type="checkbox"/>	<input type="checkbox"/>	<input type="checkbox"/>	<input type="checkbox"/>

Pump set

Pos	System component	Order No.				
5	DD10 set	2364024	<input checked="" type="checkbox"/>	<input checked="" type="checkbox"/>	<input type="checkbox"/>	<input type="checkbox"/>
6	DD10 set with product pressure regulator	2390123	<input type="checkbox"/>	<input type="checkbox"/>	<input type="checkbox"/>	<input type="checkbox"/>
7	ZIP52 set with product pressure regulator	2363856	<input type="checkbox"/>	<input type="checkbox"/>	<input checked="" type="checkbox"/>	<input checked="" type="checkbox"/>

Spray gun

Pos	System component	Order No.				
8	GM 5020EAW	2362852	<input checked="" type="checkbox"/>	<input checked="" type="checkbox"/>	<input checked="" type="checkbox"/>	<input checked="" type="checkbox"/>

Hose set

→ see Chapter 13.4	<input type="checkbox"/>	<input type="checkbox"/>	<input type="checkbox"/>	<input type="checkbox"/>
------------------------------------	--------------------------	--------------------------	--------------------------	--------------------------

Nozzles and air caps

→ see Chapters 13.2 / 13.3	<input type="checkbox"/>	<input type="checkbox"/>	<input type="checkbox"/>	<input type="checkbox"/>
------------------------------------------------------------	--------------------------	--------------------------	--------------------------	--------------------------

Additional Accessories

→ see Chapter 13.6	<input type="checkbox"/>	<input type="checkbox"/>	<input type="checkbox"/>	<input type="checkbox"/>
------------------------------------	--------------------------	--------------------------	--------------------------	--------------------------

Description	Meaning
5020	The cabinet is 100 cm; 39.4 inches wide
5010	The cabinet is 80 cm; 31.5 inches wide
5020G	The cabinet is 100 cm; 39.4 inches wide. With window in the cabinet door.
5010G	The cabinet is 80 cm; 31.5 inches wide. With window in the cabinet door.
AQ	AquaCoat

5.5 TECHNICAL DATA

5.5.1 AQUACOAT 5010/5020 ENTIRE SYSTEM

Description		Values
Compressed air Inlet		0.4–0.8 MPa 4–8 bar 58–116 psi
Air pressure quality: free from oil and water		Quality standard 6.5.2 according to ISO 8573.1, 2010 6: Particle density $\leq 5 \text{ mg/m}^3$ 5: Humidity: pressure dew point $\leq +7 \text{ }^\circ\text{C}$ 2: Oil content $\leq 0.1 \text{ mg/m}^3$
Air inlet connection		R 1/2" I
Ambient temperature	Operation	5...40 °C; 41...104 °F
	Assembly	0...40 °C; 32...104 °F
	Suspension	-20...60 °C; -4...140 °F
Relative humidity		10–95% (without condensation)
Maximum product temperature		50 °C; 122 °F
Product pH value		3.5–9
Product viscosity		see Chapter 6.7
Allowable inclination for operation		$\pm 10 \text{ }^\circ$
Sound pressure level		<i>When the cabinet is open:</i> Depending upon the product pressure generator, information can be found in the corresponding operating manual.
		<i>When the cabinet is closed:</i> The values are 10–12 dB(A) lower.
Weight (without product tank and pump)		AquaCoat 5010: 62 kg; 136.7 lb AquaCoat 5020: 70 kg; 154.3 lb

WARNING

Exhaust air containing oil!

Risk of poisoning if inhaled.

→ Provide compressed air free from oil and water.



OPERATING MANUAL



Dimensions of the entire system

Pos	AquaCoat 5010		AquaCoat 5020	
	mm	inch	mm	inch
A	1467	57.76	1467	57.76
B	556	21.89	556	21.89
C	882	34.72	1082	42.60

Including underframe with rolls: (option):

A	1572	61.89	1572	61.89
---	------	-------	------	-------

Including hose holder and gun holder (Option):

C	1028	40.47	1228	48.35
---	------	-------	------	-------

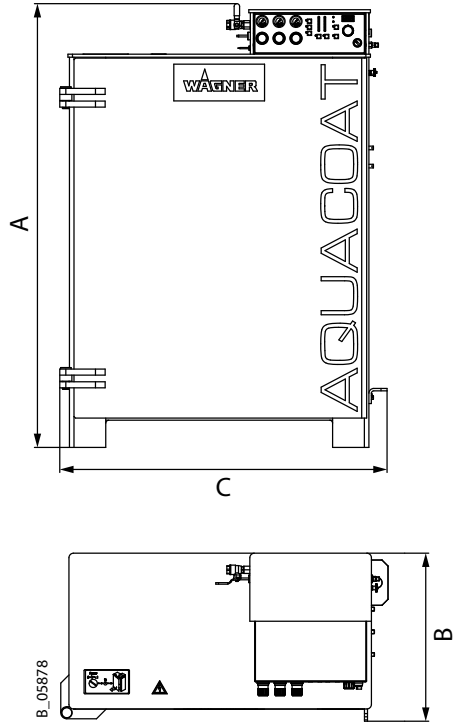

5.5.2 PRODUCT PRESSURE GENERATOR

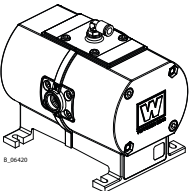
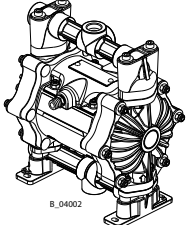
Product pressure generator	Technical data	
	Double diaphragm pump, TOPFINISH DD10	In the TOPFINISH DD10 operating manual (Order No., see Chapter 1.3.1)
	Double diaphragm pump, ZIP52 GHSS7	In the ZIP52 operating manual (Order No., see Chapter 1.3.1)

5.5.3 VM 5020W CONTROL UNIT

Description		Values
Input voltage		115 VAC–230 VAC 50 Hz/60 Hz
Input power		maximum 40 W
Output voltage		maximum 20 Vpp
Output current		maximum 1.0 A AC
High voltage		maximum 70 kV DC
Spray current		maximum 100 µA DC
Ambient temperature	Operation	5...40°C; 41...104°F
	Assembly	0...40°C; 32...104°F
	Suspension	-20...60°C; -4...140°F
Relative humidity		10–95% (without condensation)
Protection class		IP 40
Weight (without cables)		6.2 kg; 13.7 lb

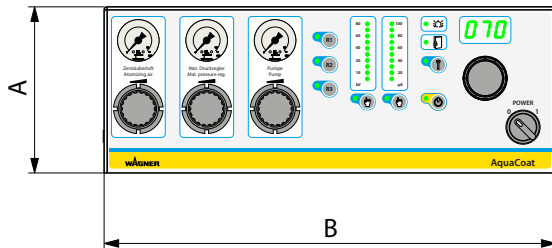

Dimensions of VM 5020W control unit

Pos	mm	inch
A	136	5.35
B	370	14.57
C	220	8.66
D	252	9.92

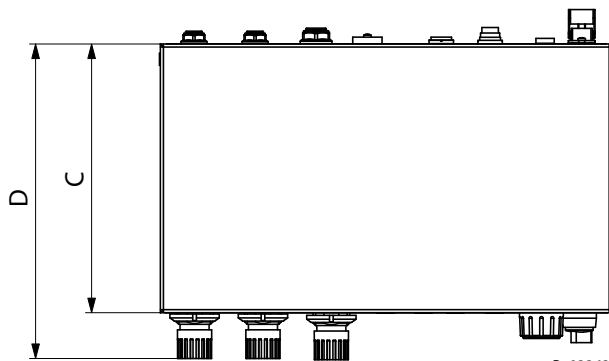

B_03362

5.5.4 GM 5020EAW SPRAY GUN

Description		Values
Maximum air pressure		0.8 MPa; 8 bar; 116 psi
Compressed air quality: free from oil and water		Quality standard 6.5.2 according to ISO 8573.1, 2010 6: Particle density $\leq 5 \text{ mg/m}^3$ 5: Humidity: pressure dew point $\leq +7 \text{ }^\circ\text{C}$ 2: Oil content $\leq 0.1 \text{ mg/m}^3$
Maximum product pressure		0.8 MPa; 8 bar; 116 psi
Product connection		to product hose: G1/4" A
Air connection		G 1/4" A
Ambient temperature	Operation	5...40°C; 41...104°F
	Assembly	0...40°C; 32...104°F
	Suspension	-20...60°C; -4...140°F
Relative humidity		10–95% (without condensation)
Maximum product temperature		50°C; 122°F
Maximum surface temperature		85°C; 185°F
Product pH value		3.5–9
Product viscosity		see Chapter 6.7
Product:	Maximum high voltage	70 kV DC
	Maximum energy	< 350 mJ
Flow rate		Depending on nozzle size (see nozzle table in Chapter 13)
Weight (without hose set)		580 g; 1.28 lb
Sound level at 0.3 MPa; 3 bar; 43.5 psi air pressure and 0.3 MPa; 3 bar; 43.5 psi product pressure *		78 dB (A)

* A-rated emission sound pressure level measured at 1 m distance, LpA 1 m, in accordance with DIN 14462: 2005.

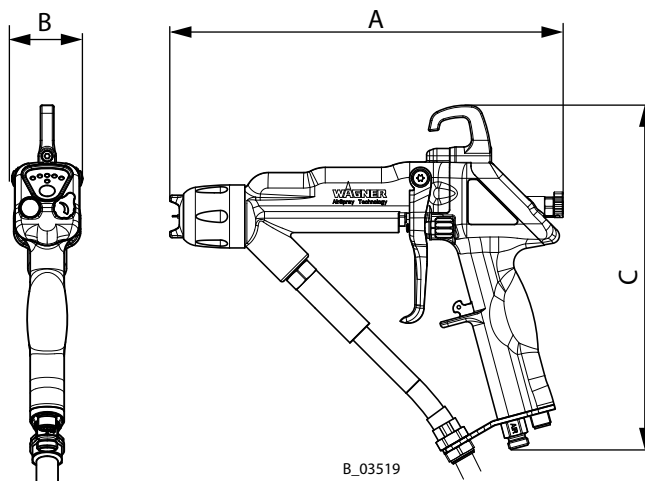

**Dimensions of
GM 5020EAW spray gun**

Pos	mm	inch
A	261	10.28
B	46	1.81
C	264	10.39

B_03519



5.5.5 AQUACOAT ELECTRIC BLOCK DIAGRAM

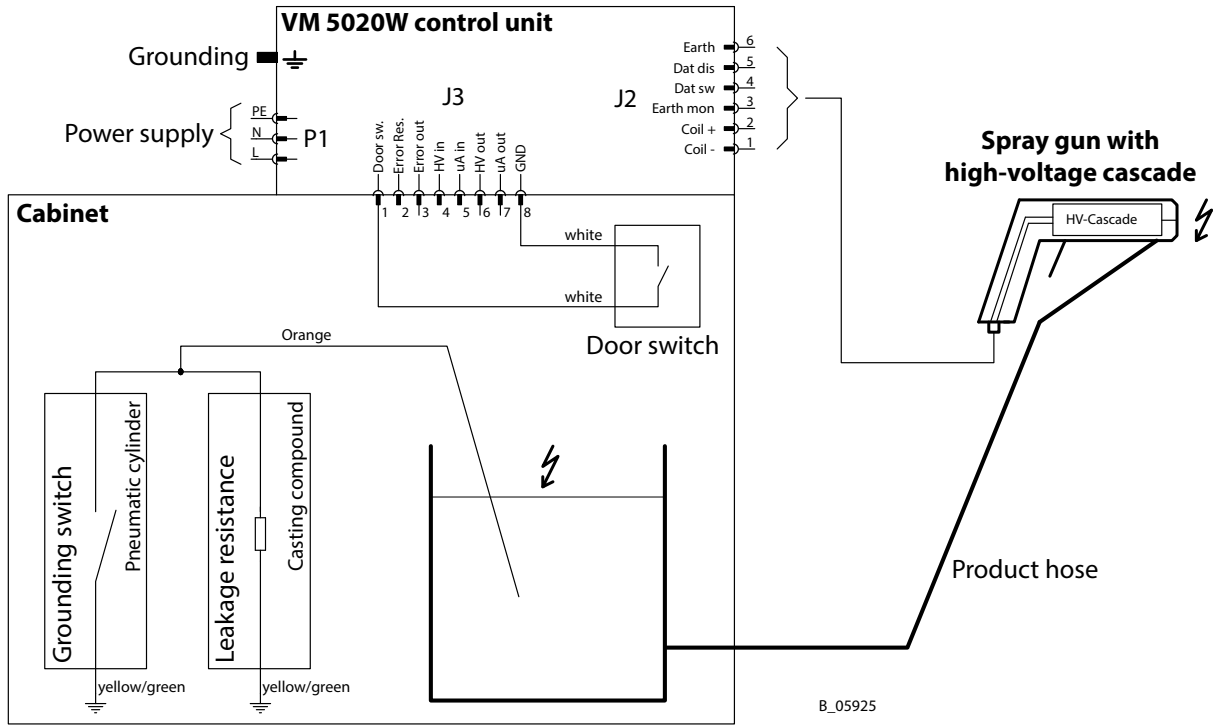

Connection	Function
J2	Gun connection
J3	External interface, see Chapter 7.6

5.6 OPERATING ELEMENTS

5.6.1 VM 5020W CONTROL UNIT

The assembled spray system can be operated and regulated with the VM 5020W control unit.

5.6.1.1 OPERATING ELEMENTS, FRONT SIDE

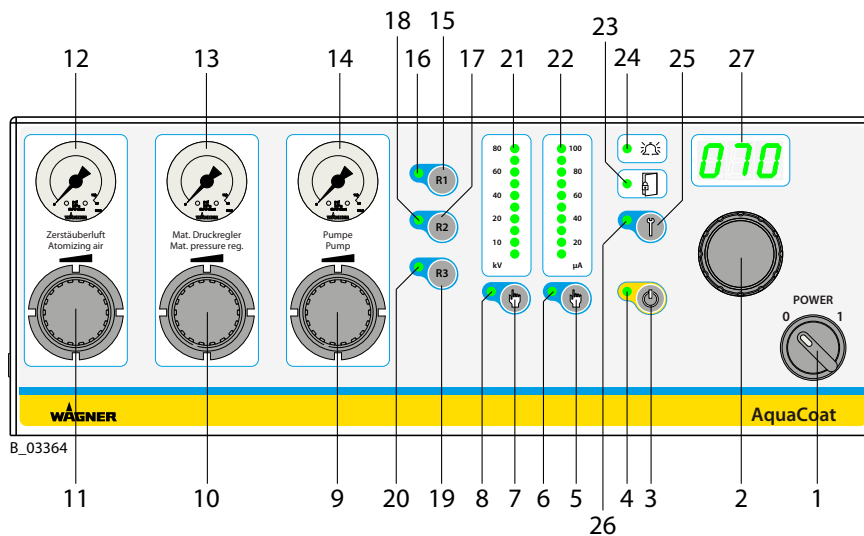

1 Selector (mains supply)

0 = Control unit switched off.

1 = Control unit switched on.

2 Universal control dial

- Dynamic digital control dial with 32 positions per revolution.
- Adjustment speed is proportional to rotational speed.
- Used to adjust high voltage and spray current.
- For setting parameter values in configuration mode.

3 Push button "Standby"

For switching to standby mode.

4 Illuminated display: "Standby"

Lights up when the device is in standby mode.

5 Push button "Spray current"

For activating the function.

The current limitation is set with the rotary controller (2) and is indicated in the LED display (27).

- Adjusting range: 10–100 μ A
- Resolution: 1 μ A

6 Illuminated display: "Spray current"

7 Push button "High voltage"

For activating the function.

The high voltage is set with the control dial (2) and is indicated in the LED display (27).

- Adjusting range: 5–70 kV
- Resolution: 1 kV

8 Illuminated display: "High voltage"**9 Regulator "Pump pressure"**

Pressure regulator for pump pressure.

- Adjusting range 0–1.0 MPa; 0–10 bar; 0–145 psi.

10 Regulator "Product pressure"

Controls the product pressure regulator (option).

- Adjusting range 0–1.0 MPa; 0–10 bar; 0–145 psi.

11 Regulator "Atomizing air"

Pressure regulator for air supply (shaping and atomizing air) to the spray gun.

- Adjusting range 0–1.0 MPa; 0–10 bar; 0–145 psi.

12 Pressure gauge "Atomizing air"

Air pressure display for the spray gun.

- Display range 0–1.0 MPa; 0–10 bar; 0–145 psi

13 Pressure gauge "Product pressure"

Pressure display for the product pressure (if option product pressure regulator).

- Display range 0–1.0 MPa; 0–10 bar; 0–145 psi

14 Pressure gauge "Pump pressure"

Display for pump pressure.

- Display range 0–1.0 MPa; 0–10 bar; 0–145 psi

15 Push button "Recipe 1"**16 Illuminated display: "Recipe 1"**

Illuminates if recipe 1 is used.

17 Push button "Recipe 2"**18 Illuminated display: "Recipe 2"**

Illuminates if recipe 2 is used.

19 Push button "Recipe 3"**20 Illuminated display: "Recipe 3"**

Illuminates if recipe 3 is used.

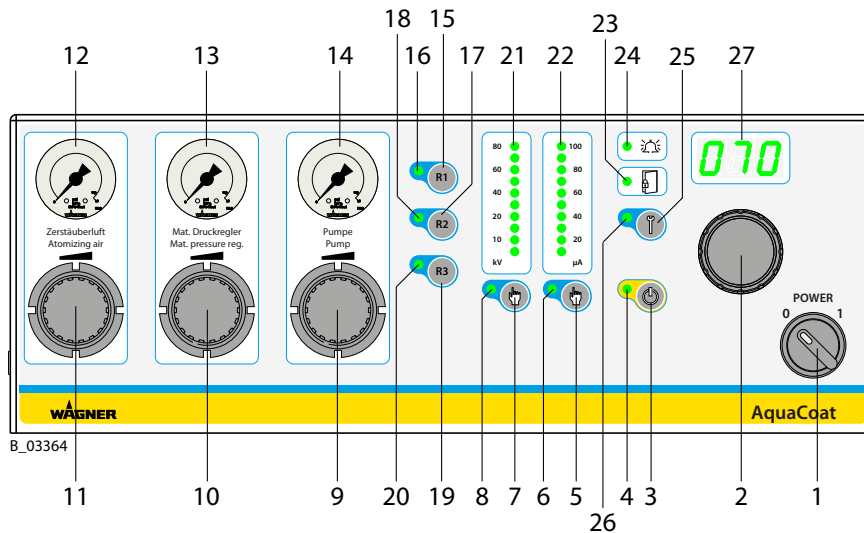

21 Illuminated display: "High voltage"

- Illuminates in green.
- Display range: 0-70 kV
- Single LED display: Nominal voltage.
- Bar display: Working voltage.

22 Illuminated display: "Spray current"

- Illuminates in green.
- Display range: 0–100 μ A
- Single display: Spraying current limit.
- Bar display: Actual spraying current.

23 Illuminated display: "Door control"

- Illuminates in green when the cabinet door is closed.

24 Illuminated display: "Fault"

- Illuminates if there is a fault in the system.

25 Push button "Service"

26 Illuminated display: "Service"

27 LED display: 7 segments, three-digit number

- Indicates the target and actual values of high voltage and spray voltage.
- Display of error number about warnings and malfunctions.
- Information about the parameter setting.

5.6.1.2 CONNECTIONS ON THE REAR SIDE

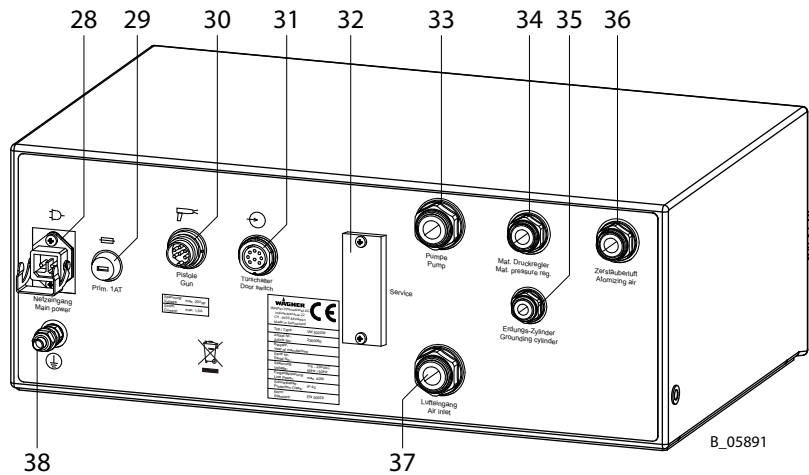

28 Mains input terminal

Connection for mains cable with safety clip.

29 Primary fuse

1.0 Ampere slow-acting.

30 Gun connection

To connect a spray gun.

31 Door switch connection

Connection for the door switch cable.

32 Cover of the service connection

For WAGNER service personnel only!

33 Connection pump air

Hose connector \varnothing 10 mm; 0.39 inches.

34 Product pressure regulator connection

Hose connector \varnothing 8 mm; 0.32 inches.

35 Grounding switch air connection

Hose connector \varnothing 6 mm; 0.24 inches.

36 Atomizing air connection

Hose connector \varnothing 8 mm; 0.32 inches.

37 Compressed air Inlet

Hose connector \varnothing 10 mm; 0.39 inches.

38 Grounding (self-locking nut)

Connection for the grounding cable (signal ground).

5.6.2 PRODUCT PRESSURE GENERATOR

5.6.2.1 MAINTENANCE WORK ON THE PUMP

For preparation, commissioning and maintenance work at the pump, proceed as follows:

1. Relieve system pressure according to Chapter [7.4.4](#).
2. Close spray guns.
3. Switch off control unit. (The pressure regulators continue to function.)
4. Open cabinet door (pull hard).
5. Work in accordance with pump's operating manual. While doing so:
 - Only metal tanks may be used for product and flushing agents. Ground the tank with the AquaCoat cabinet's potential equalization.
 - Regulate product pressure at the pump pressure regulator (9) on the switched-off control unit and, if necessary, at the product pressure regulator (10).
 - Regulate atomizing air at the atomizing air regulator (11).
 - Use the spray gun for product delivery valve.
 - The return valve is the ball valve on the pump output and/or after the product pressure regulator.

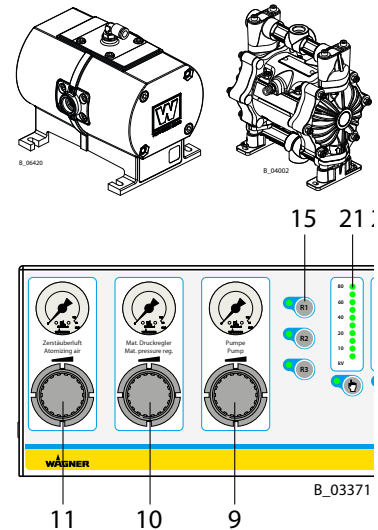

OPERATING MANUAL



5.7 GM 5020EAW SPRAY GUN

5.7.1 COMPONENTS

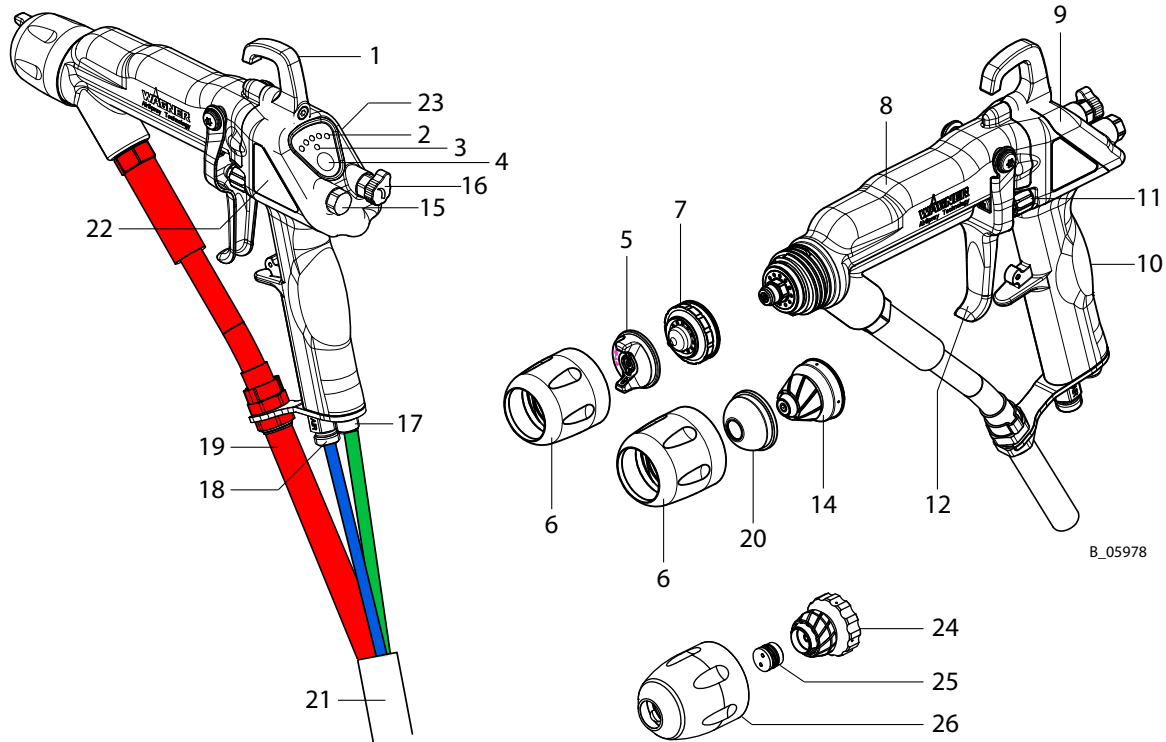

Pos	Description
1	Suspension hook
2	Display (spray current and recipe)
3	Display standby and fault
4	Operating button (standby and recipe change)
5	Air cap (Accessories: see Chapter 13.3.1)
6	Union nut
7	Flat jet nozzle, AF 5000 (Accessories: see Chapter 13.3)
8	Adapter
9	Cover
10	Handle
11	Adjusting screw product valve (Stop)
12	Trigger lever
14	Nozzle, AWR5000 (Accessories: see Chapter 13.2.2)

Pos	Description	
15	Sealing plug	
16	Air regulation	
17	Electric cable connection	
18	Atomizing air connection	
19	Product connection	
20	Air cap, AR 5000 (Accessories: see Chapter 13.2.2)	
21	Protective hose	
22	Type plate left	
23	Type plate right	
24	Nozzle insert, EAWRV	Accessories: see Chapter 13.2.1
25	Nozzle, EARV	
26	Union nut, EAWRV	

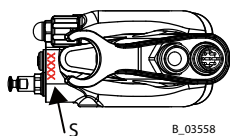

Note:
The gun type (T) is specified on the type plate and the serial number (S) is specified on the underside of the handle.

5.7.2 MODE OF OPERATION

Recipe display

When the spray gun is connected to the control unit and the control unit is switched on, the pre-defined recipe (R1, R2 or R3) is shown on the gun display (2) as follows.

Recipe 1 → ●○○○○ R1

Recipe 2 → ●●●○○ R2

Recipe 3 → ●●●●● R3

Recipe change R1 → R2 → R3 → R1

Press the operating button (4) and hold the button pressed for at least 2 seconds to go forward 1 recipe.

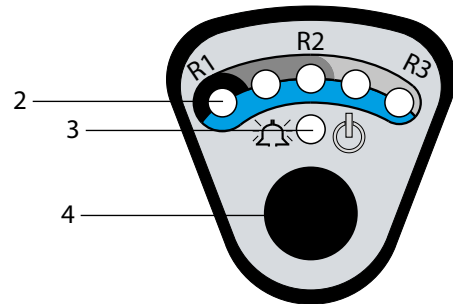

B_03182

Display (2) → ●●○○○ = Recipe values changed temporarily:

If the operating key (4) is pressed for 2 seconds, the saved recipe values for the previously selected recipes numbers will be reloaded from the memory.

Status display during spraying mode

During spraying mode (trigger lever pressed), the status is shown in the display (2) by LEDs.

LED display	Description
LEDs 1 - 3 light up green	The spray gun is working in an optimal high-voltage spray current range.
One or both right-hand LEDs illuminate in orange. (Warning display: You can continue working without any limitations.)	Spray current too high. Possible causes: - Spray gun too close to the work piece - Contamination of the spray gun



Trigger functions

The trigger can be used to activate, one after the other, the various functions of the spray gun.

Distance	Description
1	Atomizing air open.
2	Atomizing air open and electrostatically (high voltage) activated. → Display (2) for "spray current" on the spray gun ●○○○○ to ●●●●● activated.
3	Atomizing air open, electrostatically (high voltage) activated and product valve open.
4	Overall way of trigger.

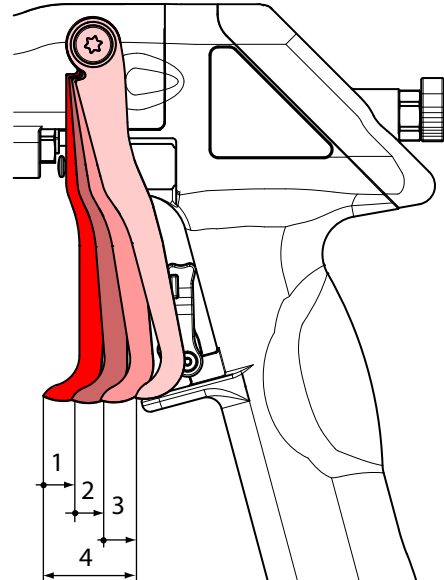

B_03157

- An increase in the force needed to pull the trigger back will be perceived at the position where the product valve opens.
- For spraying without high voltage, the high voltage can be switched off using the operating button (4). Press the operating button (4) briefly: High voltage is switched off. The standby display (3) illuminates.
- In the event of a malfunction the spray gun switches to "standby" operating mode and the display (3) illuminates.
- The relationship between shaping air and atomizing air is set using the **air regulator** (16).

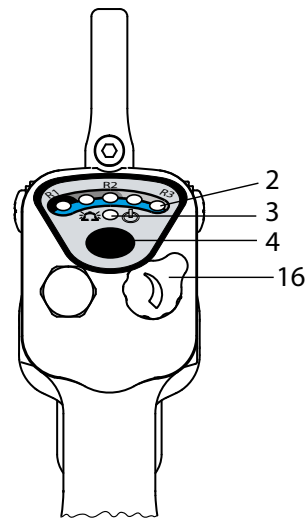

B_03183

5.7.3 SPRAYING PROCEDURE FOR ROUND JET AIR ATOMIZING

In this process, the spray product is fed to the nozzle with a pressure of approx. 0.05–0.2 MPa; 0.5–2 bar; 7–29 psi. The atomizing air at approx. 0.25 - 0.4 MPa; 2.5 - 4 bar; 36 - 58 psi produces a soft spray jet, which largely eliminates the problem of overlapping boundaries at the edges.

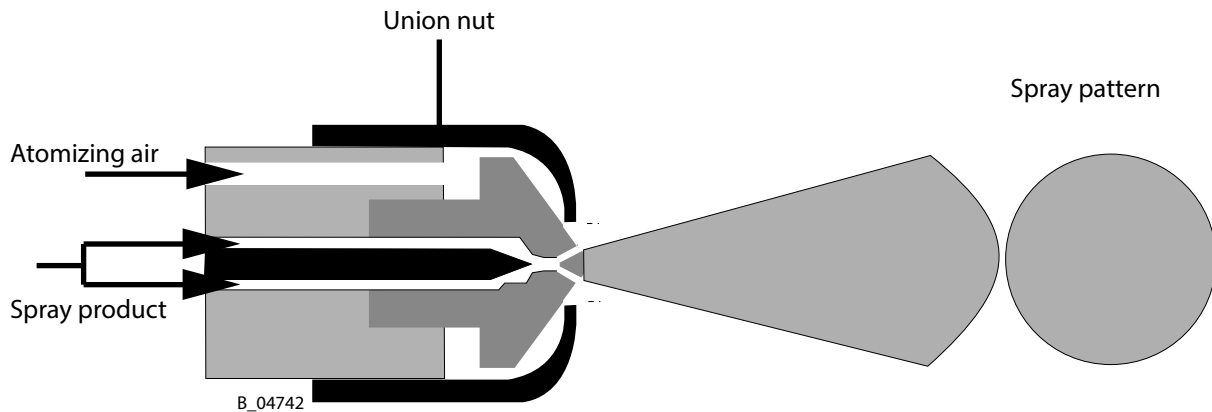

Advantages

- Thin layers
- Uniform coating thickness
- Perfect finish

Nozzle selection

There are various round jet nozzles available as accessories for the respective spray product and the discharge quantities:

- AWR 5000 with a fixed spray jet width. Several nozzles and air caps sizes.
- EAWRV 5000 with a variable spray jet width.

5.7.4 SPRAYING PROCEDURE FOR FLAT JET AIR ATOMIZING

In this process, the spray product is fed to the nozzle at a pressure of 0.05–0.2 MPa; 0.5–2 bar; 7–29 psi. The atomizing air at approx. 0.25 - 0.4 MPa; 2.5 - 4 bar; 36 - 58 psi produces a soft spray jet, which largely eliminates the problem of overlapping boundaries at the edges. The shaping air allows modification of the spray jet. There are various nozzles and air caps available as accessories for the respective spray product and the discharge quantities.

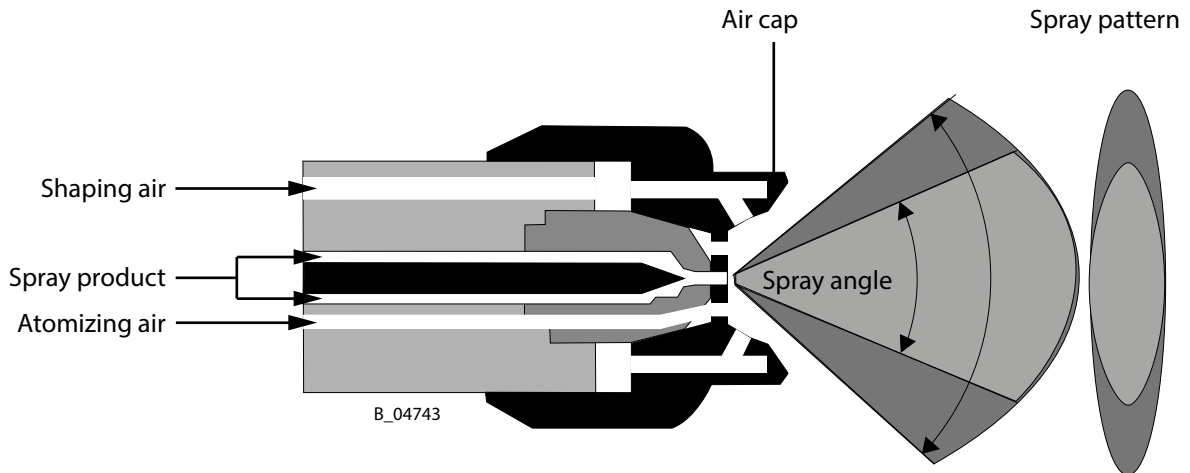

Advantages

- Large range of adjustment of the spray jet
- Thin layers
- Uniform coating thickness
- Perfect finish

5.7.5 THE ELECTROSTATIC EFFECT

The in-system electrically loaded paint particles atomized by the spray gun are transported to the grounded object by kinetic and electrostatic energy where they adhere, finely distributed on the object being sprayed.

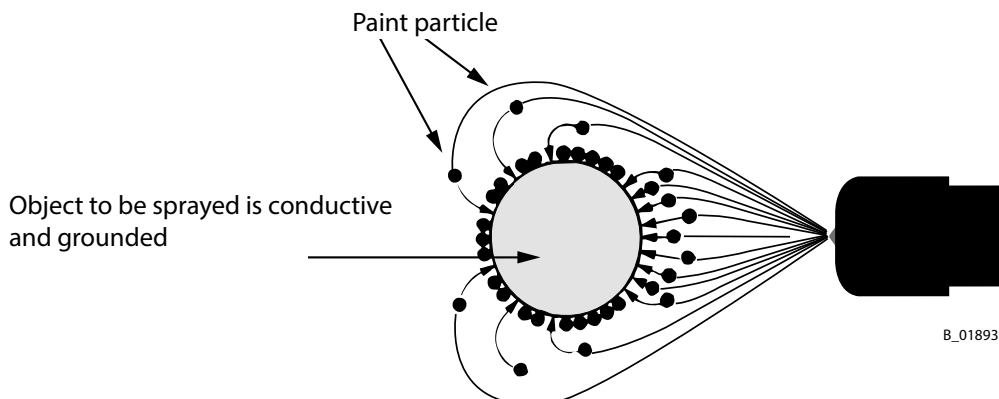

Advantages

- Very high application effectiveness
- Low over spray
- Coating of entire circumferences due to the electrostatic effect
- Savings in working time

6 ASSEMBLY AND COMMISSIONING

6.1 TRAINING OF ASSEMBLY/COMMISSIONING STAFF

- The assembly and commissioning staff must have the technical skills to safely commission the device.
- When assembling, commissioning and carrying out all work, read and follow the operating manuals and safety regulations for the additionally required system components.

A skilled person must check to ensure that the device is in a reliable state after it is installed and commissioned.

6.2 STORAGE AND INSTALLATION CONDITIONS

Until the point of assembly, the device must be stored in a dry location, free from vibrations and with a minimum of dust. The device must be stored in closed rooms.

For ambient temperature and air humidity, see Chapter [5.5.1](#).

Long-term storage

- See Chapter [8.1.5](#).
- For recommissioning, proceed according to following chapters.

6.3 TRANSPORTATION

For underframe with rolls: The device can be moved on the rollers for short distances.

Without underframe: The device can be transported using a pallet jack. Use the recessed area on the underside of the cabinet for this purpose.

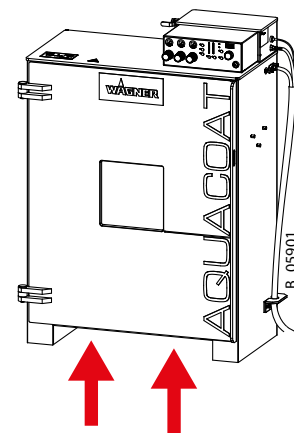

WARNING

Inclined ground!

Risk of accidents if the device rolls away/falls.

- Place the device on horizontal floor.
- The wheels should be fixed or replaced by leveling feet and secured.
- Do not tilt the device during shifting / transporting.



6.4 ASSEMBLY AND INSTALLATION

Check the individual components of the AquaCoat spraying system against the consignment note. Familiarize yourself with the mode of functioning of the individual components, reading the enclosed operating manuals thoroughly. Note the special requirements of the designated electrostatic air spray procedure.

6.4.1 ASSEMBLING THE AQUACOAT SYSTEM

Accessories (option)

1. – Mount underframe with rolls, according to the assembly manual 2367143.
 - Mount hose holder in accordance with Chapter [14.5.4](#).
 - Mount gun holder (see Chapter [14.5.5](#)).
 - Place tub insert into AquaCoat cabinet.

Pump set

All required parts are included in the scope of delivery of the pump set (see Chapter [14.3](#)).

The cabinet contains two air hoses:

- The air hose \varnothing 10 mm; 0.39 inch is connected with the control unit, pump air connection.
- The air hose \varnothing 8 mm; 0.32 inches is connected with the control unit, product pressure regulator connection.

Procedure:

2. Screw the pump to pump support (see Chapter [14.3](#)).
3. Screw the orange potential equalization line (see Chapter [5.1](#)) to pump's grounding connection. (Grounding connection see pump's operating manual.)
4. Mount suction hose on pump inlet.
5. Pump's air supply: Connect air hose \varnothing 10 mm; 0.39 inches (see Chapter [5.1](#)) to pump's compressed air inlet.
6. DD10-/ZIP52 pump with product pressure regulator: Connect air hose \varnothing 8 mm; 0.32 inches (see Chapter [5.1](#)) to product pressure regulator.

Hose set

7. Dismount the VM 5020W control unit in accordance with Chapter [10.5](#).
8. Mount hose set on the cabinet in accordance with Chapter [8.2.4](#) (assembly).

OPERATING MANUAL



Secure cables and hoses

9. Secure al cables and hoses with cable ties in the AquaCoat cabinet.
 - The door switch moves up and down on the RH cabinet wall. It must be ensured that no cables and hoses are located within the travel of the door switch.

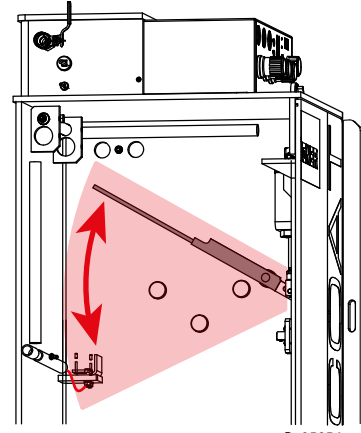

B_05954

Spray gun

10. Mount product hose, air hose and gun cable to spray gun.

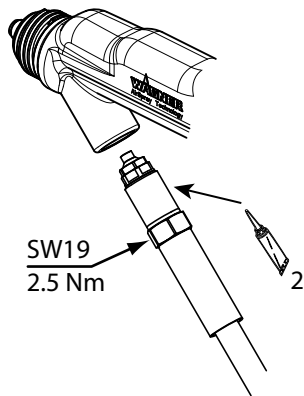

B_05983

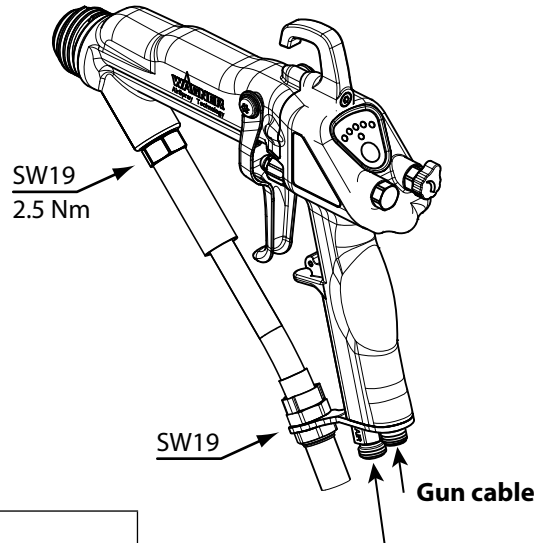

Pos	Order No.	Description
2 *	9992698	Vaseline white, PHHV II

* Use Vaseline sparingly

Air hose

When screwing on the air hose, a second open-ended/ring spanner must be used for bracing.

Control unit

11. Carefully push the VM 5020W control unit back again to the limit stop. Note the connecting lines and connecting cables at the back of the control unit!
12. Screw the VM 5020W control unit on the cabinet.

Additional Accessories (option)

13. Mount additional Accessories, if available.

6.4.2 VENTILATION OF THE SPRAY BOOTH

The electrostatic spraying equipment may only be operated in defined spraying areas and in accordance with the EN 12215 standard or under comparable ventilation conditions. The electrostatic spraying equipment must be locked to the technical ventilation so that the coating product supply and the high voltage are not effective as long as the technical ventilation is not operated with the minimum exhaust air volume flow or a larger exhaust air volume flow.

Ensure that the excess coating product (overspray) will be collected up safely.

WARNING

Toxic and/or flammable vapor mixtures!

Risk of poisoning and burns.

- Operate the device in a spray booth approved for the working materials.
- or-
- Operate the device on an appropriate spraying wall with the ventilation (extraction) switched on.
- Observe national and local regulations for the exhaust air speed.

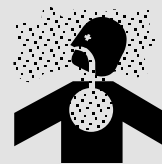

6.4.3 PNEUMATIC CONNECTIONS

WARNING

Hose connections!

Risk of injury and damage to the device.

- Do not mix up hose connections of product hose and air hose.



- You must ensure that only dry, clean atomizing air is used in the spray gun. Dirt and moisture in the atomizing air worsens the spraying quality and spray pattern. For compressed air quality, see Chapter [5.5.1](#).

WARNING

Overpressure!

Risk of injury from bursting components.

- The operating pressure must not exceed the value shown on the type plate.



6.4.4 PRODUCT CONNECTIONS

WARNING

Electrical discharges!

Danger due to electrically charged product lines.

- The conductive sheath of the product hose must not be removed and the connections to the ground potential must not be loosened:
 - Gun side: Do not disconnect the product hose from the hose holder.
 - Cabinet side: Do not loosen the cabinet's knurled nut and the grounding cable in the cabinet.



6.5 GROUNDING

It is important for systems safety and to achieve an optimum coating that all system components such as work pieces, conveyors, paint supply, control unit and booth or spraying stand are perfectly grounded.

WARNING

Heavy paint mist if grounding is insufficient!

Danger of poisoning.

Insufficient paint application quality.

- Ground all device components.
- Ground the work pieces to be coated.

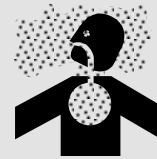

A poorly grounded work piece causes:

- very bad wrap around,
- uneven coating,
- back spraying to the spray gun, i.e., contamination.

Prerequisites for perfect grounding and coating:

- Clean work piece suspension.
- Grounding of spray booth, conveyor system and suspension on the building side in accordance with the operating manuals or the manufacturer's information.
- Grounding of all conductive parts within the working area.
- The grounding resistance of the work piece may not exceed 1 M Ω (megaohm) (ground leakage resistance measured at 500 V or 1000 V).
- Connect the AquaCoat cabinet to the signal ground.
- Connect all ground cables using a short and direct route.
- Safety shoes and gloves, if used, must be static dissipative.

Grounding scheme (example)

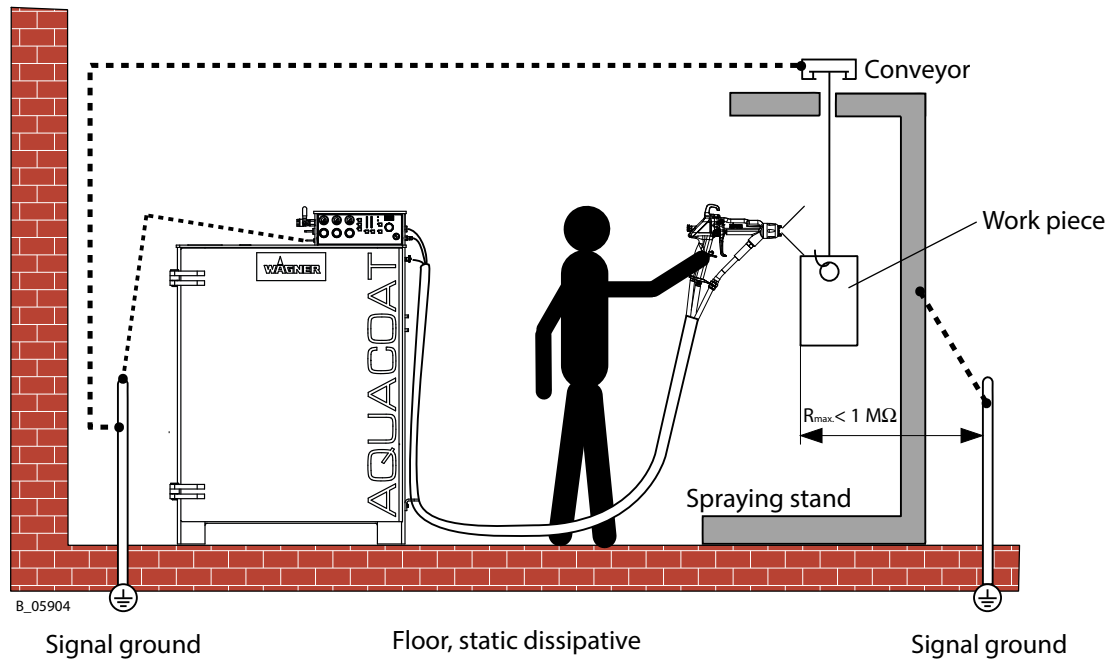

Minimum cable cross-section

AquaCoat cabinet	4 mm ² ; AWG 12
Conveyor	16 mm ² ; AWG 6
Spray booth	16 mm ² ; AWG 6
Spraying stand	16 mm ² ; AWG 6

- Safe operation of the AquaCoat system is only guaranteed with a grounding connection.
- Connect all ground cables using a short and direct route.

Tank

- All paints, flushing agents and waste tanks have to be made of metal.
- All tanks in the cabinet must be connected to the potential equalization. All further tanks must be grounded.

6.6 SAFETY CHECKS

- Carry out safety checks in accordance with Chapter [8.2.3](#).

6.7 PREPARATION OF WATER-BASED LACQUER

The viscosity of the lacquer is of great importance. The best spraying results are obtained with values between 15 and 30 DIN/4 seconds (measured in immersion flow cup DIN 4 mm; 0.16 inches).

In the case of application problems contact the lacquer manufacturer.

6.7.1 VISCOSITY CONVERSION TABLE

mPa s	Centipoise	Poise	DIN Cup 4 mm 0.16 inch	Ford Cup 4	Zahn 2
10	10	0.1		5	16
15	15	0.15		8	17
20	20	0.2		10	18
25	25	0.25	14	12	19
30	30	0.3	15	14	20
40	40	0.4	17	18	22
50	50	0.5	19	22	24
60	60	0.6	21	26	27
70	70	0.7	23	28	30
80	80	0.8	25	31	34
90	90	0.9	28	32	37
100	100	1	30	34	41
120	120	1.2	33	41	49
140	140	1.4	37	45	58
160	160	1.6	43	50	66
180	180	1.8	46	54	74
200	200	2	49	58	82
220	220	2.2	52	62	
240	240	2.4	56	65	
260	260	2.6	62	68	
280	280	2.8	65	70	
300	300	3	70	74	
320	320	3.2			
340	340	3.4			
360	360	3.6	80		
380	380	3.8			
400	400	4	90		

6.8 COMMISSIONING

6.8.1 PREPARATION

Before every start-up, the following points should be observed as laid down in the operating manual:

- For underframe with rolls (option): Lock all four swivel castors with the footbrake.
- Only metal tanks may be used for product and flushing agents, no plastic tanks.
- Check the permissible pressures.
- Check all connections for leaks.
- Check hoses for damage in accordance with Chapter [8.2.6](#).

Connect the compressed air

- Connect the AquaCoat system to the compressed air source (8).

Fill the devices with flushing agent

The devices are tested during manufacturing with oil or other fluids. Possible residues must be flushed out of the circuits with a solvent (flushing agent) before commissioning.

- Fill the empty device with flushing agent in accordance with Chapter [5.6.2.1](#) pump's operating manual. Suction the product: Increase the air pressure gradually until the pump starts. Do not let the pump run too quickly while suctioning.

⚠ NOTICE

Impurities in the spraying system!

Spray gun blockage, products harden in the spraying system.

- Flush the spray gun and paint supply with a suitable flushing agent before commissioning.

6.8.2 COMMISSIONING

⚠ CAUTION

Electrical discharge when using coated product tanks!

Risk of injury; product charge not optimal.

- Ensure that the metal part of the tank is connected to the potential equalization line (e.g., remove coating from around the connection point).



Check the unit for leaks

1. Place metallic product tank (14) containing a suitable medium (e.g., flushing agent or water) in the AquaCoat cabinet.
2. Immerse in tank the suction system (13).
3. Clamp the potential equalization line (22) to the product tank (14).
4. To perform a leak test on the entire installation, the pressure is slowly increased step by step until the maximum pressure as indicated on the type plate for the system and product pressure generator fitted is reached.
 - "Pump pressure" regulator up to 0.8 MPa; 8 bar; 116 psi
 - With product pressure regulator: "Product pressure" regulator up to 0.8 MPa; 8 bar; 116 psi
5. Maintain the pressure for 5 minutes and check all connecting parts for leaks.
6. Reduce the pressure, when the seal of the system has been ascertained.

7. Flush system through well (see Chapter [8.1.3](#)).
8. Relieve system pressure (see Chapter [7.4.4](#)).
9. Remove flushing agent.

Preparation for spraying

1. Fill the metallic product tank (14) with lacquer and place in the cabinet.
2. Immerse in tank the suction system (13).
3. Clamp the potential equalization line (22) to the product tank (14).
4. Connect the AquaCoat system to the electric socket with the electric cable (9).
5. Close the cabinet door (2).
6. Switch on mains switch on the VM 5020W.
7. The system is ready for use.

Example for AquaCoat with TOPFINISH DD10 double diaphragm pump

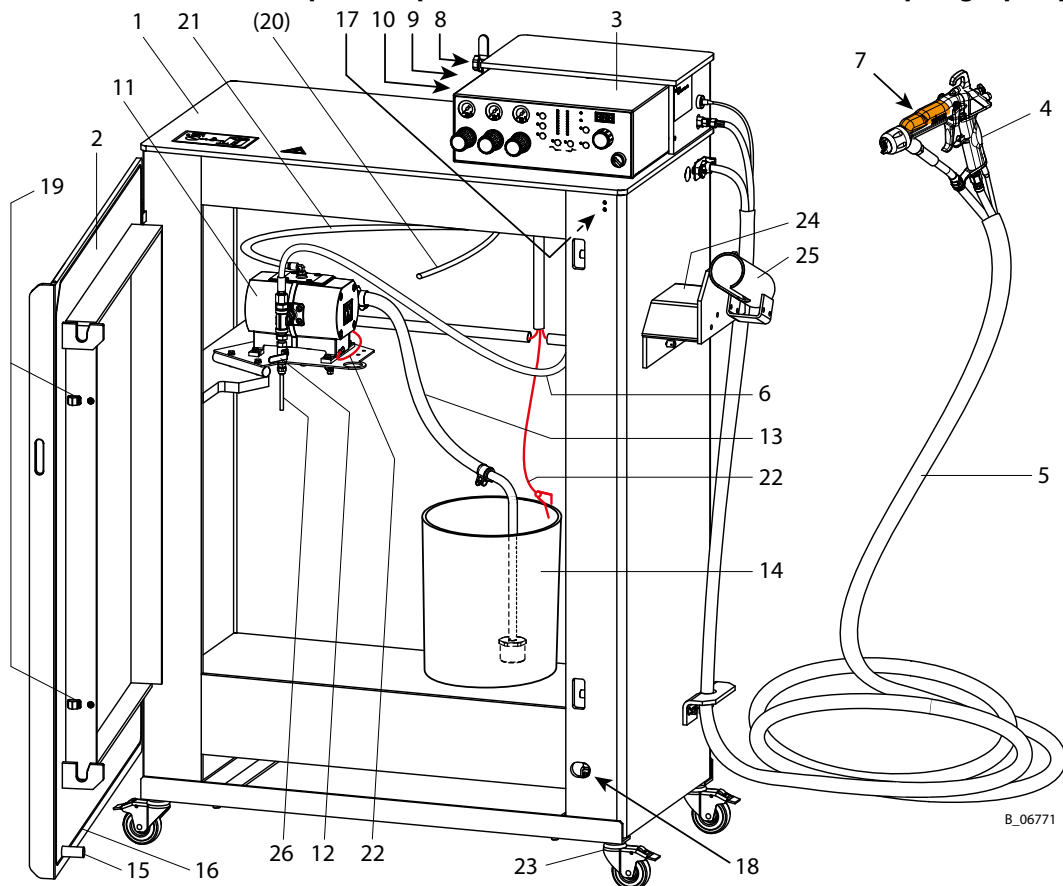

B_06771

6.8.3 VERIFYING A SAFE OPERATIONAL CONDITION

A skilled person must check to ensure that the device is in a reliable state after it is installed and commissioned.

This includes:

- Carry out safety checks in accordance with Chapter [8.2.3](#).
- Function test in accordance with Chapter [11](#).

7 OPERATION

7.1 TRAINING THE OPERATING STAFF

- The operating staff must be qualified to operate the entire system.
- The operating staff must be familiar with the potential risks associated with improper behavior as well as the necessary protective devices and measures.
- Before work commences, the operating staff must receive appropriate system training.

7.2 ELECTRICAL DISCHARGE

In the nozzle area of the spray gun electrical discharges can occur. They are completely non-hazardous for human health. However, they can cause a shock reaction.

CAUTION

Electrical discharge!

Shock reaction.

- Maintain a safety distance of 100 mm; 4 inches from the nozzle area of the spray gun during the spraying process and at least 20 seconds after the end of the spraying process.



Danger zone

In order to avoid electrical discharges, a distance of 100 mm or 4 inches must be maintained from the work piece and other grounded objects during and after the spraying process for at least 20 seconds.

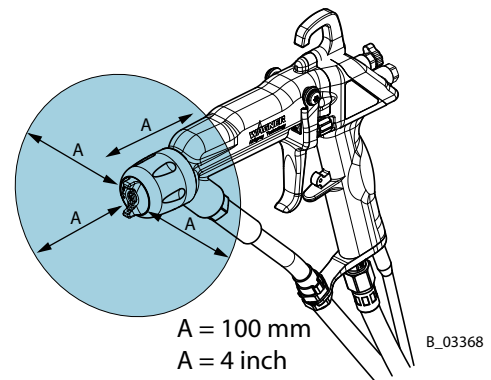

7.3 EMERGENCY DEACTIVATION

In the case of unforeseen occurrences, proceed as follows:

1. Close main tap (1).
2. Switch off control unit (2) at main switch (3).
3. Open cabinet door (4) (pull hard).
4. Relieve product pressure by opening ball valve (5).

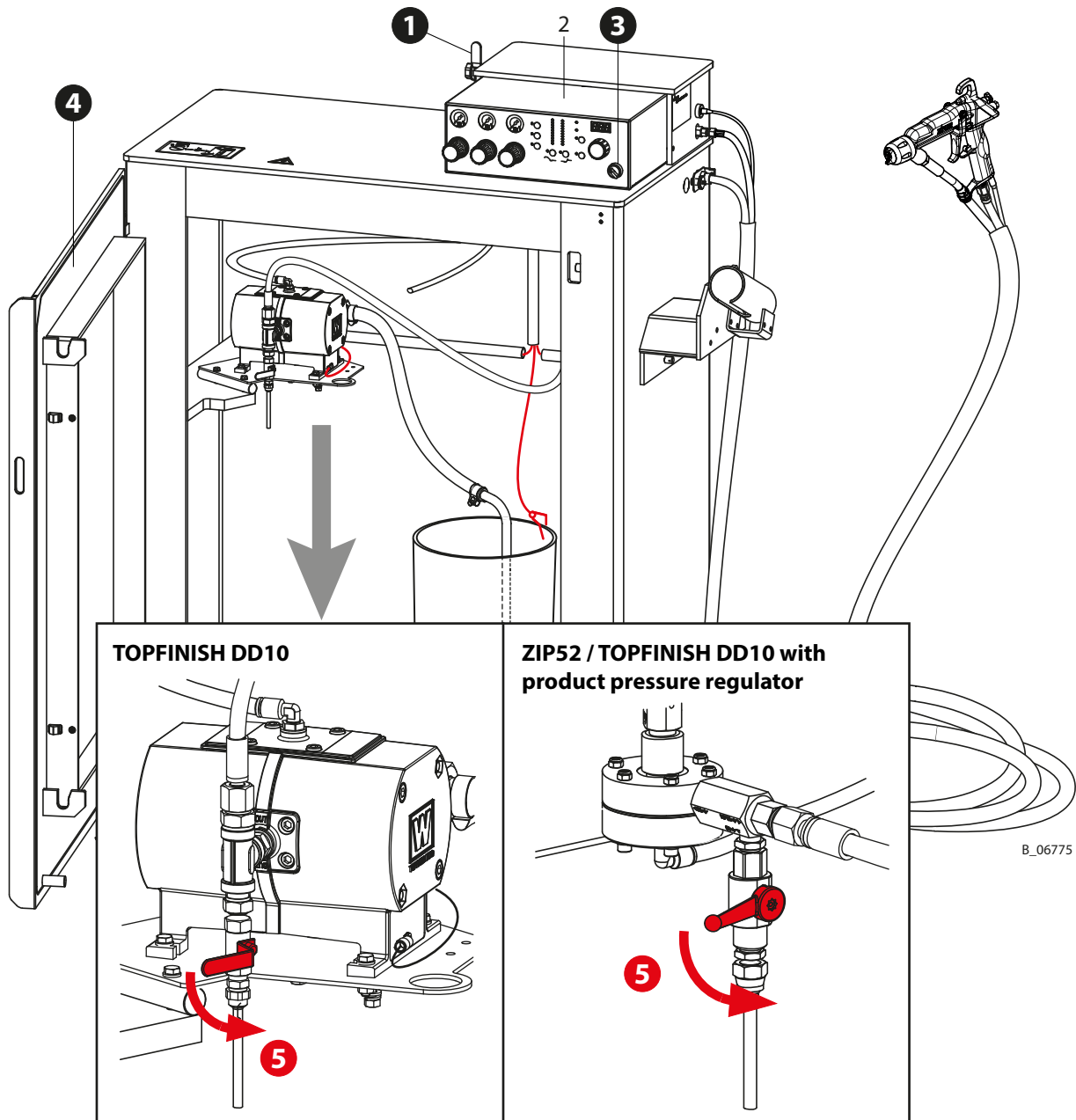

7.4 WORKING

Ensure that:

- The regular safety checks are carried out in accordance with Chapter [8.2.3](#),
- Commissioning is carried out in accordance with Chapter [6.8](#).

7.4.1 CHECKING THE SPRAY PATTERN (WITHOUT ELECTROSTATICS)

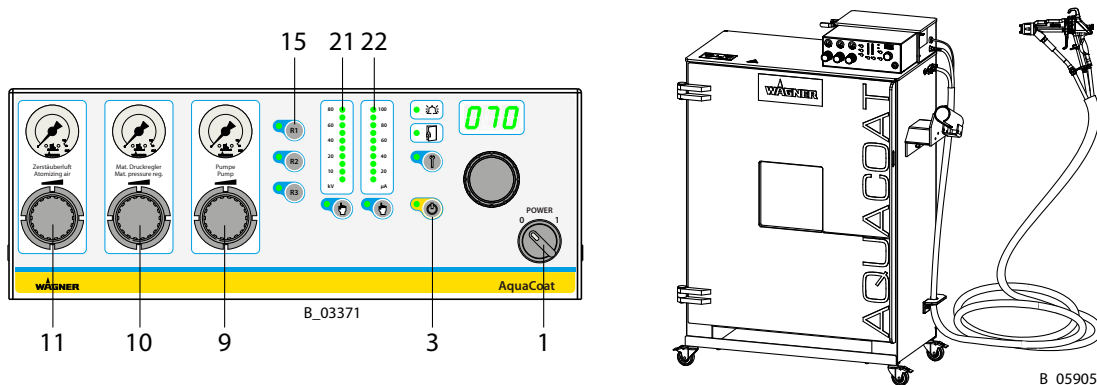

Start air-spraying (without electrostatics)

1. Switch off control unit. (The pressure regulators continue to function.)
2. Set pump pressure regulator (9) depending upon the paint viscosity (see operating manual of the product pressure generator).
 - DD10 pump: approx. 0.2–0.6 MPa; 2–6 bar; 30–90 psi
 - DD10-/ZIP52 pump with product pressure regulator: approx. 0.3–0.6 MPa; 3–6 bar; 40–90 psi
3. DD10-/ZIP52 pump with product pressure regulator:
Set product pressure regulator (10) to approx. 0.05–0.2 MPa; 0.5–2 bar; 7–30 psi operating pressure.
4. Set atomizing air regulator (11) to approx. 0.2–0.4 MPa; 2–4 bar; 30–60 psi.
5. Open air regulator at the rear of the gun.
6. Set the union nut as far as the stop.
7. Spray (actuate trigger) and check the atomization.
8. – DD10 pump:
Use the pump pressure regulator (9) and atomizing air regulator (11) to set the spray pressure to a point at which optimal product atomization is achieved.
– DD10-/ZIP52 pump with product pressure regulator:
Use the product pressure regulator (10) and atomizing air regulator (11) to set the spray pressure to a point at which optimal product atomization is achieved.
9. Flat jet process: with the air adjustment on the gun, set the ratio of shaping air/atomizing air so as to achieve an optimum spray pattern.

Changing the Flow Rate

- Adapt product pressure.
- Use a different fan spray nozzle (see Chapter [13](#)).
- Limit the valve needle stroke with the adjustment screw on the side of the gun.

Spray pattern and air regulation

The spray pattern can be optimally adjusted to suit the object being sprayed using the air regulator. The illustration shows the influence of the regulator on the spray pattern. Other nozzle sizes can be used to obtain larger or smaller spray patterns.

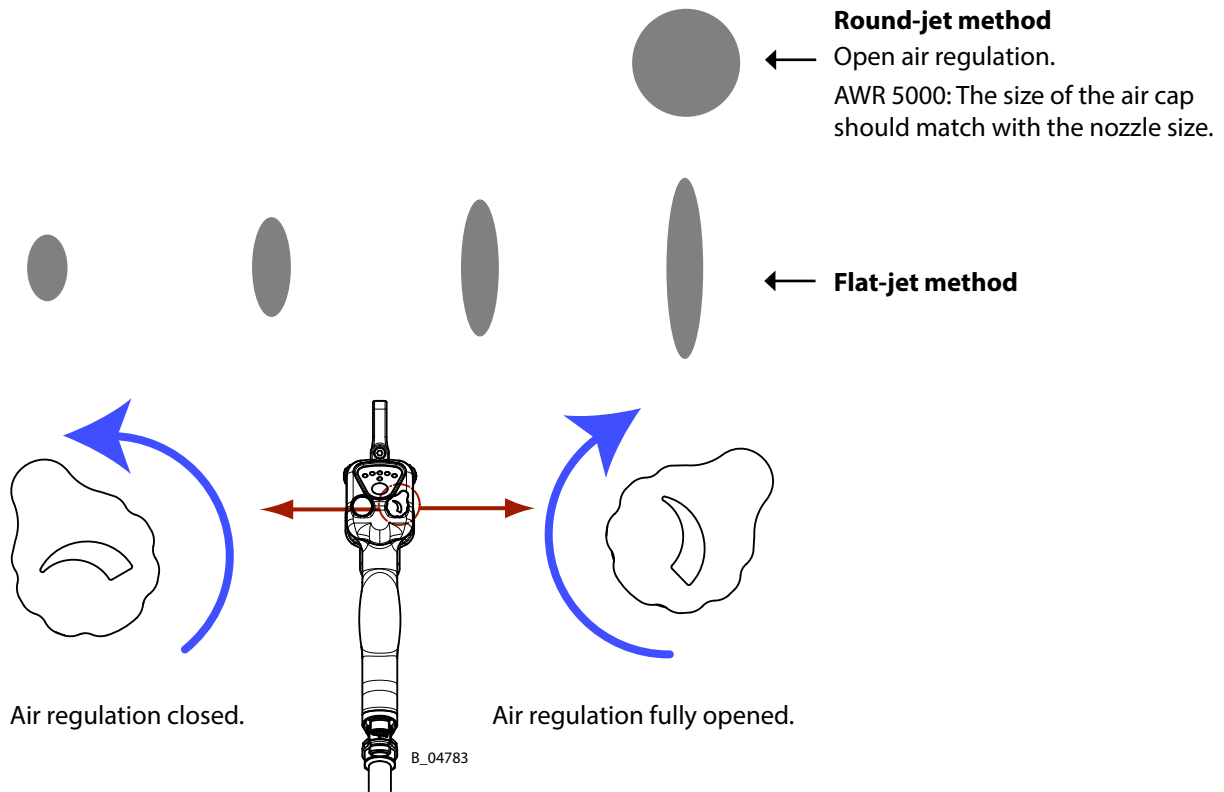

Adjustable EAWRV 5000 round jet nozzle

By turning the union nut the spray pattern can be adjusted to suit the object being sprayed. The illustration shows the influence of the turning on the spray pattern.

1. Set the union nut as far as the stop.
2. Open maximum 1/4 turn. The atomizing is good in this area.
 - The union nut should not protrude beyond the nozzle body.
 - Always fully open the air regulation.

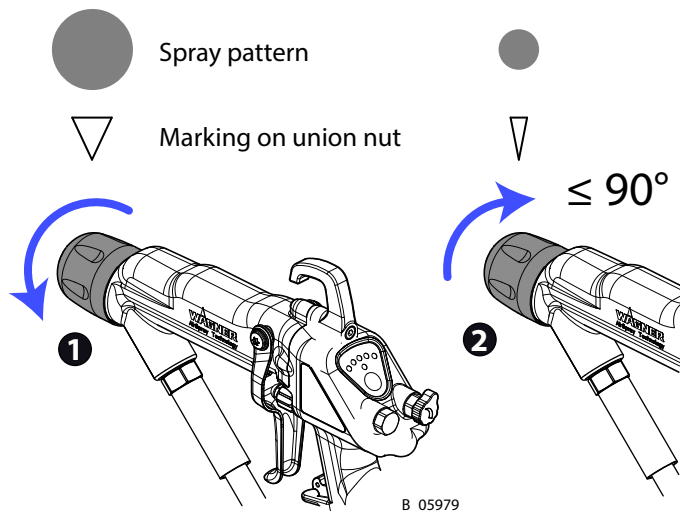

7.4.2 STARTING THE SYSTEM

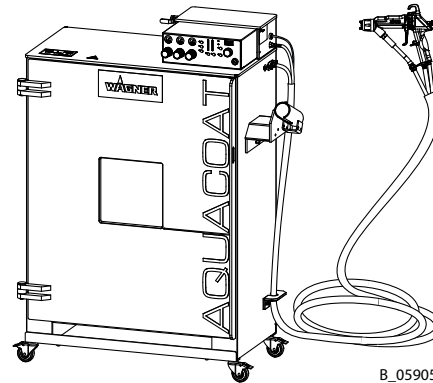
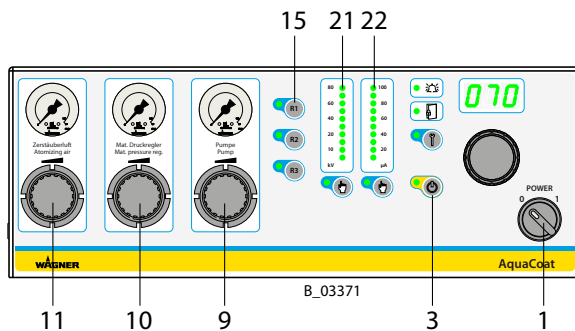

Control unit, VM 5020W

- Set the main switch (1) to position 1.
→ During the start-up phase, the device automatically performs an internal function test and then automatically switches to recipe 1 (15).
- Set the desired recipe.
→ See Chapter [7.4.7](#) and the following for information on how to operate the control unit.

Product supply

- Open the compressed air supply.
- Set pump pressure regulator (9) depending upon the paint viscosity (see operating manual of the product pressure generator).
 - DD10 pump: approx. 0.2–0.6 MPa; 2–6 bar; 30–90 psi
 - DD10-/ZIP52 pump with product pressure regulator: approx. 0.3–0.6 MPa; 3–6 bar; 40–90 psi
- DD10-/ZIP52 pump with product pressure regulator:
Set product pressure regulator (10) to approx. 0.05–0.2 MPa; 0.5–2 bar; 7–30 psi operating pressure.
- Set atomizing air regulator (11) to approx. 0.2–0.4 MPa; 2–4 bar; 30–60 psi.

Spray gun

- Spray on a test object (pull trigger).
 - If the trigger is now actuated at the spray gun, the high voltage is switched on and both displays (21) and (22) change from dot to bar display, i.e. the actual value of the high voltage (21) and the actual value of the spray current (22) are displayed.
 - The high voltage can be switched on and off with the push button (3).
- DD10 pump:
Adjust the pump pressure regulator (9) and atomizing air (11) with respect to the nozzle and object. → See Chapter [7.4.3](#).
 - DD10-/ZIP52 pump with product pressure regulator:
Adjust the product pressure regulator (10) and atomizing air regulator (11) in accordance with the nozzle and object. → See Chapter [7.4.3](#).

7.4.3 SPRAYING

1. Insert the desired nozzle into the spray gun.
2. Commissioning the system → see Chapter [7.4.2](#).
3. Open air regulator at the rear of the gun.
4. Spray on a test object (pull trigger).
5. – DD10 pump:
Use the pump pressure regulator (9) and atomizing air regulator (11) to set the spray pressure to a point at which optimal product atomization is achieved.
- DD10-/ZIP52 pump with product pressure regulator:
Use the product pressure regulator (10) and atomizing air regulator (11) to set the spray pressure to a point at which optimal product atomization is achieved.

Rule of thumb: Set atomizing air pressure approx. three times higher than the product pressure.

Round-jet method

6. Open air regulation.
7. Changing the EAWRV 5000 spray jet width: Switch off high voltage. Turning the union nut in accordance with Chapter [7.4.1](#).

Flat-jet method: Changing the spray jet width

8. Change the width of the spray jet by turning the air regulator (at the rear of the spray gun, see illustration) or by appropriate selection of the nozzle.

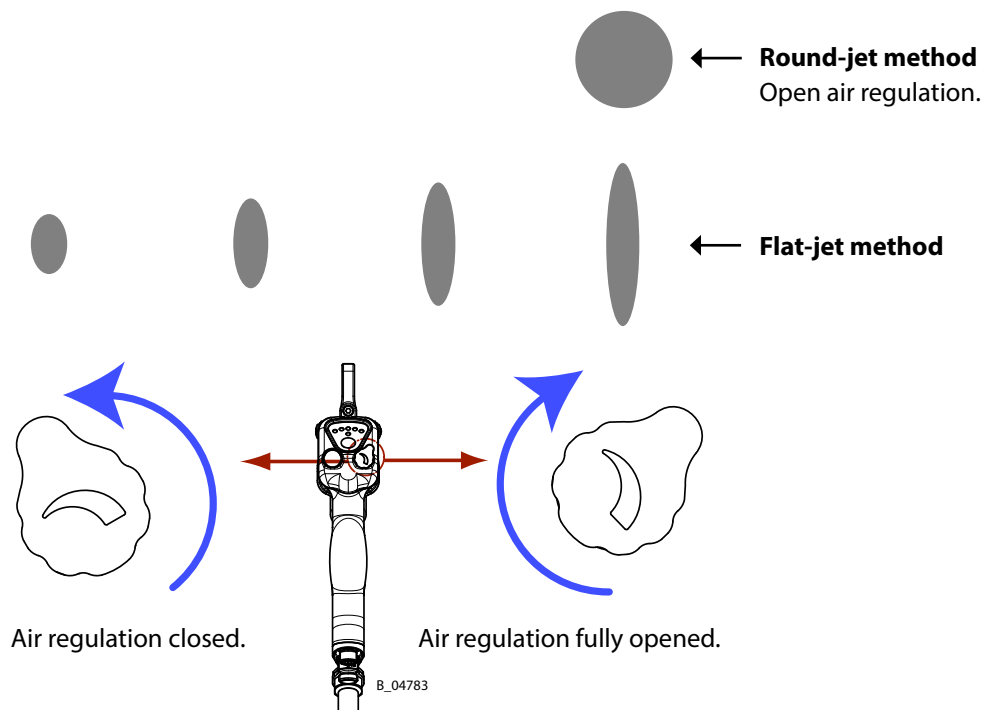

Flow rate

9. Flow rate may be able to be reduced by:
 - Minimizing the product pressure.
 - Use a different nozzle size.
→ For discharge quantity measurements see Chapters [13.2.3](#) (round jet) and [13.3.3](#) (flat jet).
 - Limit the valve needle stroke with the adjustment screw on the side of the gun.

7.4.4 PRESSURE RELIEF/WORK INTERRUPTION

The pressure must always be relieved:

- after the spraying tasks are finished.
- Before servicing or repairing the spraying system.
- Before carrying out cleaning tasks on the spraying system.
- Before moving the spraying system to another location.
- Before something must be checked on the spraying system.
- Before the nozzle is removed from the spray gun.

Procedure

1. Close the spray gun.
2. Switch off control unit.
3. Close the compressed air supply.
4. Open cabinet door (pull hard).
5. Place grounded metal tank for return product under the return tube.
6. Open the return valve slowly.
7. When no further overpressure is detected, close the return valve.
8. Point the spray gun into the grounded metal tank for return product.
9. Open spray gun to relieve the pressure. Avoid splashback.
10. When no further overpressure is detected, close the spray gun.
11. Close cabinet door again.

In the case of a clogged nozzle, proceed in accordance with Chapters [7.4.5](#) and [7.4.6](#).

7.4.5 CHANGING THE NOZZLE, CHANGING FROM ROUND JET/FLAT JET

Flush spray gun

1. Switch off control unit.
2. Relieve pressure → Chapter [7.4.4](#).
3. Connect the system to the flushing agent supply.
4. Set product pressure. Close atomizing air regulator.
5. Thoroughly flush out the spray gun.
6. Relieve pressure → Chapter [7.4.4](#).

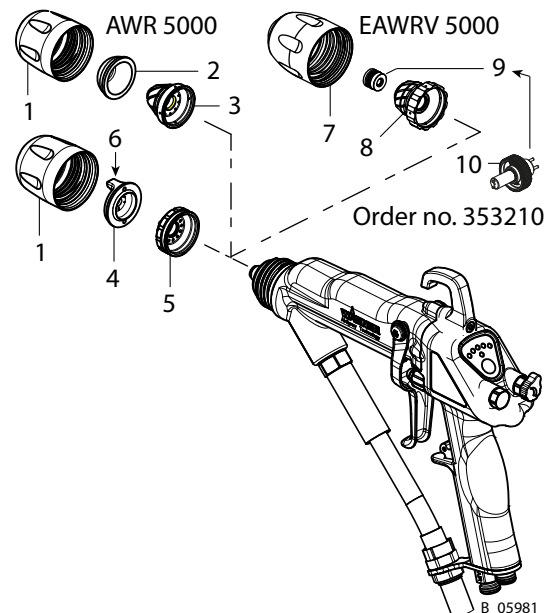

Dismount the nozzle**– Flat jet**

1. Unscrew the union nut (1) by hand.
2. Remove AF 5000 air cap (4).
3. Unscrew and remove AF 5000 flat jet nozzle (5) by hand.
4. Clean the spray gun front carefully with damp cloth.

– AWR 5000 – round jet

1. Unscrew the union nut (1) by hand.
2. Remove AR 5000 air cap (2). Unscrew AWR 5000 nozzle (3) by hand and remove it.
3. Clean the spray gun front carefully with damp cloth.

– EAWRV 5000 – round jet

1. Unscrew the EARV union nut (7) by hand.
2. Unscrew and remove EARV nozzle (8) by hand.
3. Unscrew nozzle insert (9) from nozzle (8) using air nozzle spanner (10).
4. Clean the spray gun front carefully with damp cloth.

Mount nozzle**– Flat jet**

1. Screw in and slightly tighten AF 5000 flat jet nozzle (5) by hand.
2. Put the AF 5000 air cap (4) in place. Screw the union nut (1) onto the spray gun body.
3. Set the desired flat jet level with the air cap horns (6) and then slightly tighten the union nut by hand.

– AWR 5000 – round jet

1. Screw on and slightly tighten AWR 5000 nozzle (3) by hand.
2. Position AR 5000 air cap (2). Screw the union nut (1) onto the spray gun body and slightly tighten by hand.

– EAWRV 5000 – round jet

1. Screw on EAWRV nozzle insert (9) into nozzle (8) using air nozzle spanner (10). Nozzle insert and nozzle body must be flush, subsequently do not continue turning.
2. Screw on and slightly tighten EARV nozzle (8) by hand.
3. Select EARV union nut (7) depending on the viscosity: HV or LV. Screw the union nut onto the spray gun body and slightly tighten by hand.

7.4.6 CLEANING OF THE NOZZLE PARTS

The nozzle parts (2, 3, 4, 5, 6, 8 and 9) may only be immersed into a cleaning solvent recommended by the lacquer manufacturer and must be removed again immediately. They may only remain in a cleaning solvent for a short time.

Clean these parts with a brush and dry them with a cloth or a blow gun.



7.4.7 STARTING UP THE VM 5020W CONTROL UNIT

1. Turn switch to position 1.
2. All LEDs on the control unit illuminate for approximately 1 second.
3. The hardware version and the software version are shown on the display alternately in succession.



Hardware version



Software version

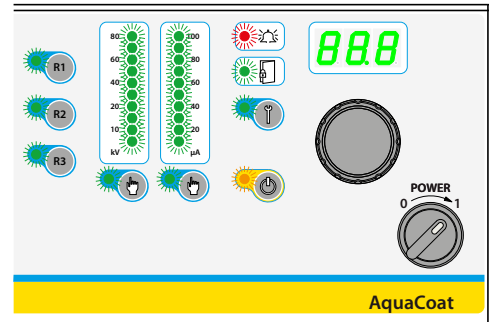

B_03372

4. After a few seconds, the control unit is ready for operation.

Note:

Each starting sequence is concluded by allocating the saved set data in recipe "R1".

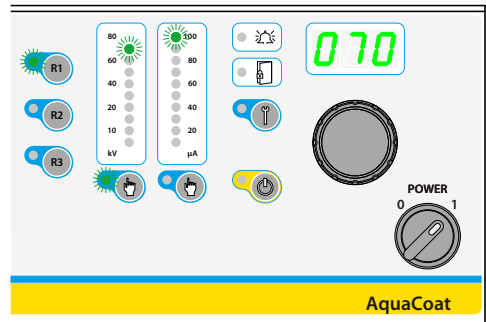

B_03374

7.4.8 SET AND SAVE RECIPES

Nominal values for the high voltage (kV) and for the spray current limiter (µA) are stored in a recipe. As standard, the following values are saved in the factory in the 3 storage places available for recipes:

Recipe No.	Set value - high voltage in kV	Target spray current limitation in µA
R1	70	100
R2	60	100
R3	40	80

Recipes 1-3 can be selected and saved directly with the program buttons "R1", "R2" and "R3". Once the recipe required has been called up, the individual coating parameters can be called up and changed using the corresponding selection buttons (see Chapters 7.4.9, 7.4.10). When a parameter is changed, the LED on the left of the program button goes out and indicates to the user that a parameter value has been changed.

Rejecting parameter values

To reuse the originally set values, press the program button briefly. The modified values are not taken over.

Saving parameter values

However, if the modified values should be saved, press and hold the corresponding program button for approx. 2 seconds until the LED beside the button starts to flash quickly. The modified values are then saved.

7.4.9 SETTING THE HIGH VOLTAGE

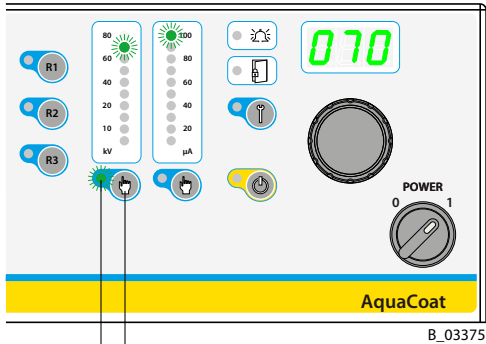

8 7

B_03375

Procedure

1. Press the "High-voltage" button (7) to adjust the high voltage. The LED (8) indicates that high voltage is selected.

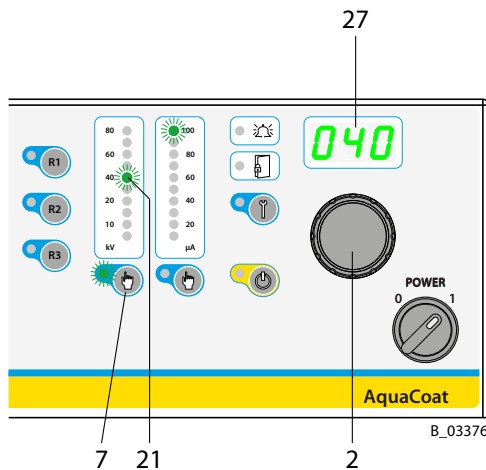

7 21

27

B_03376

2. The high voltage can now be adjusted using the universal rotary controller (2) between 5 to 70 kV with a resolution of 1 kV. The corresponding value is indicated in the LED display (27).

Above the "High-voltage" button (7) is the "High-voltage" bar graph display (21). If the control unit is in the ready position, this light strip shows the set value as a dot.

7.4.10 SETTING THE CURRENT LIMITATION

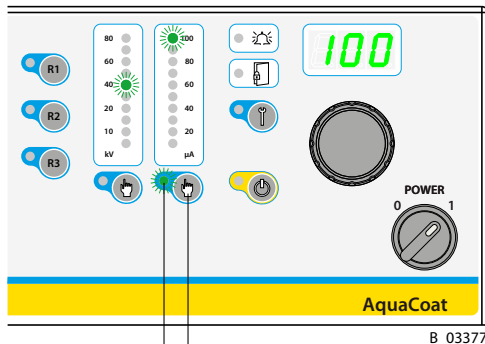

Procedure

1. Press the "Current limitation" button (5) to adjust the limitation of the spray current.

The LED (6) indicates that current limitation is selected.

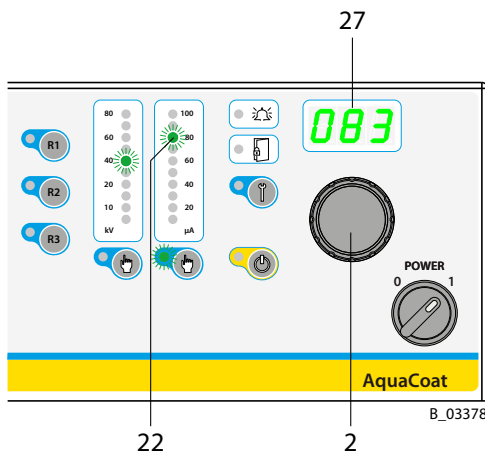

2. The current limitation can now be adjusted using the universal rotary controller (2) between 10-100 μA with a resolution of 1 μA .

The corresponding value is indicated in the LED display (27).

Above the "Current limitation" button (5) is the "Current limitation" bar graph display (22). If the control unit is in the ready position, this light strip shows the set value as a dot.

The current limitation is an adjustable threshold. If this threshold is exceeded, for example, by the spray gun having approached the object being sprayed, the high voltage is adjusted downwards until the threshold is no longer exceeded.

The set values for the target high voltage (40 kV) and for spray current limitation (83 μA) that are shown in the examples are saved in R2 by pressing and holding (for > 2 seconds) the receipt push button.



7.4.11 DISPLAY DURING SPRAYING MODE

Control unit in standby position

Ready to spray using R2 recipe (see figure).

The nominal value LEDs illuminate as dots and the high-voltage value is digitally displayed in the LED display. If you press the current limiter push button, the set nominal value for the spray current limiter is digitally displayed in the LED display.

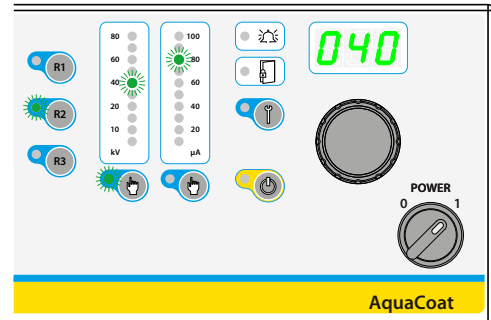

B_03379

Spray display

Spraying using recipe R2:

By actuating the trigger on the spray gun, high voltage is produced. The LEDs light up in a bar display showing the actual values. The current actual value of the activated push button for the high voltage (kV) is digitally displayed on the LED display. If the push button for the spray current limiter is pressed, the relevant LED lights up and the corresponding actual value in μA appears on the LED display.

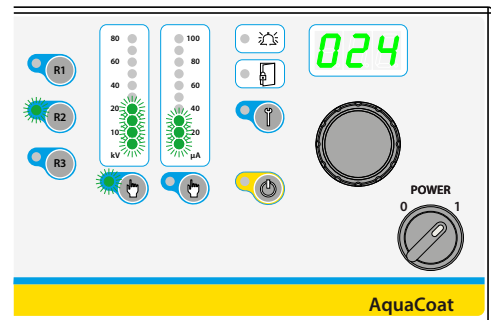

B_03380

7.4.12 STANDBY MODE

If you want to spray without high voltage, select standby mode. Briefly press the "Standby" push button (3), LED (4) will illuminate. All other LEDs are extinguished.

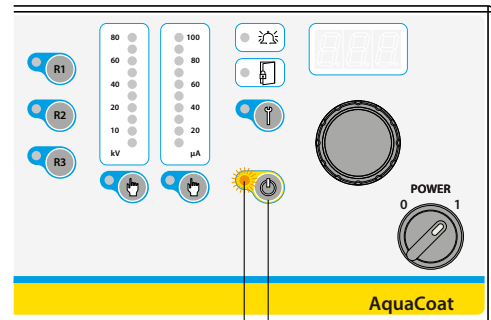

B_03381

4 3

Press push button (3) to return from this standby mode to the previously saved standby mode (see figure).

Note:

This function can be activated and used from the gun.

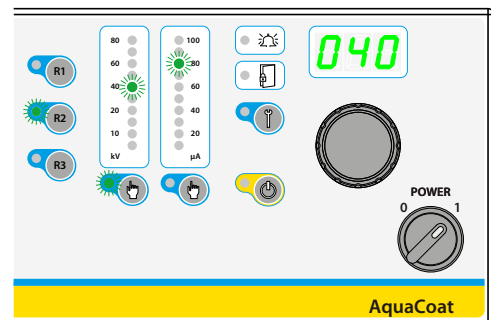

B_03379



7.4.13 OPERATING HOURS COUNTER/SERVICE DISPLAY

- Two hour counters are integrated into the control unit.
- The absolute counter measures the ongoing hours of operation of the spray gun.
 - The maintenance intervals for the spray gun can be determined and monitored with the maintenance hours counter.

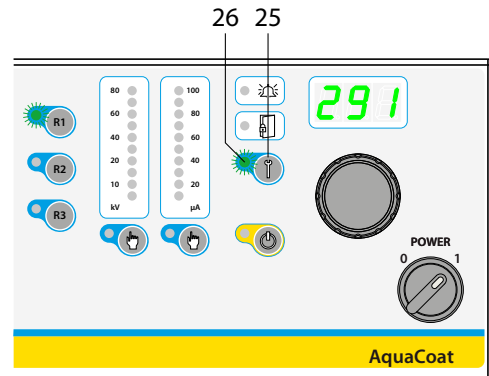

B_03382

Push button "Service"

Press the "Service" button (25) to go from the standby position of the control unit to the service menu display.

Structure of the service menu (LED display 26 illuminates):

Push button	Description of display
R1	Display of the spray gun's absolute accrued operating hours. Display format: Counter reading < 999 hours: 001 = 1 hour; 291 = 291 hours. Counter reading > 1000 hours: 1.23 = 1230 h; 45.2 = 45200 h Maximum display value = 99.9 = 99900 h Flashing lines are then displayed.
R2	Display of temporary maintenance counter and resetting this counter (see Chapter 7.4.13.1).
R3	Set maintenance interval in hours, activate or lock this function (see Chapter 7.4.13.1).

7.4.13.1 MAINTENANCE DISPLAY SETUP

When the device is first used, the function for the service interval is deactivated. This function can be activated with the "R3" push button (19). The maintenance interval limit can be set within a range of 0 to 999 hours.

Setting and saving the maintenance interval limit in hours

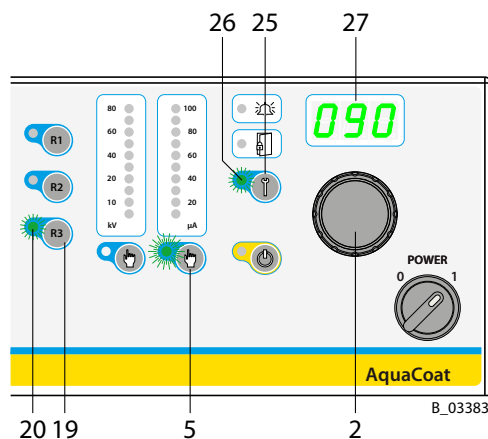

B_03383

Procedure

1. Press the "Service" button (25) to access the service menu. LED (26) lights up.
2. Actuate the push button R3 (19) for a short time; the LED (20) display lights up.
3. Use the dial (2) to set the maintenance interval limit you want (e.g., 90 hours).
4. Check setting in the LED display (27).
5. The value is saved by pressing down the "Spray current" push button (5) until the LED display (27) starts to flash.

Review counter status since last service carried out on gun

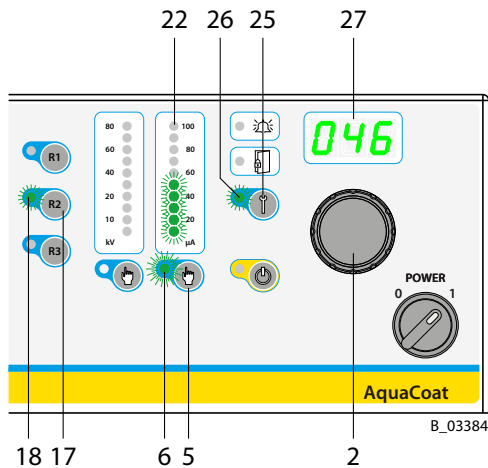

Procedure

1. Press the "Service" button (25) to access the service menu. LED (26) lights up.
2. Actuate the push button R2 (17) for a short time; the LED (18) display lights up.
3. Read off display in the LED display (27). In the example, 46 hours have passed since realization of the last spray gun service. The bar display to the left (22) indicates that 50% of the set interval time has passed.
4. By keeping push button (5) pressed down, the display in the LED display (27) can be set to "0" (reset after expiry of the set interval limit).

7.4.13.2 "CARRY OUT SERVICE" DISPLAY

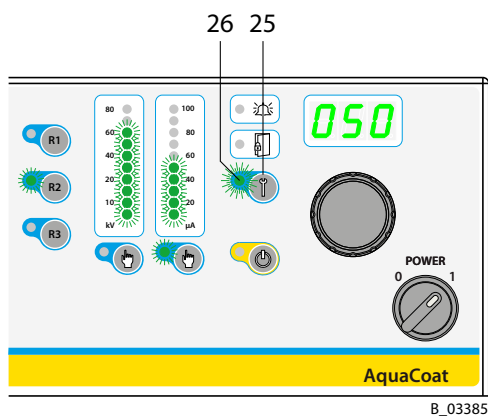

Prerequisite

The "Service interval limit" function is activated (see Chapter [7.4.13.1](#)).

"Service spray gun"

Once the time for the defined maintenance interval has expired, the LED display (26) starts to flash.

The flashing service display merely acts as a warning. You can continue working without any limitations.

7.5 DEVICE CONFIGURATION

7.5.1 OVERVIEW OF PARAMETERS

Parameter		Value	Description
C12	External set value specification	off (factory setting)	The target values for high voltage in kV and current limitation in μ A are adjusted at the front control panel of the control unit.
		on	<ul style="list-style-type: none"> - The set values for high voltage in kV and current limitation in μA are predefined using the interface's two analog power inputs. Application example: Set value specification by a superordinate controller (PLC). - Set values can no longer be adjusted at the front control panel. All recipe functions (save, call up recipe, etc.) are locked.
C13	Lock	off (factory setting)	Lock is deactivated.
		on	<ul style="list-style-type: none"> Operating inhibit is activated. - You can select recipes and control functions. - The set values (kV and μA) cannot be adjusted.
		pro	<ul style="list-style-type: none"> Lock pro (program). - You can select recipes and control functions. - The target values (kV and μA) can be adjusted but cannot be saved in the recipes.
C19	Reset recipes	no (factory setting)	No reaction
		res	All programs are set to delivery condition, if "res" is saved with the "Service" button.
C20	Reset configuration	no (factory setting)	No reaction
		res	All configuration parameters are set to delivery condition (factory setting), if "res" is saved with the "Service" button.

7.5.2 ACCESS TO THE DEVICE CONFIGURATION MODE

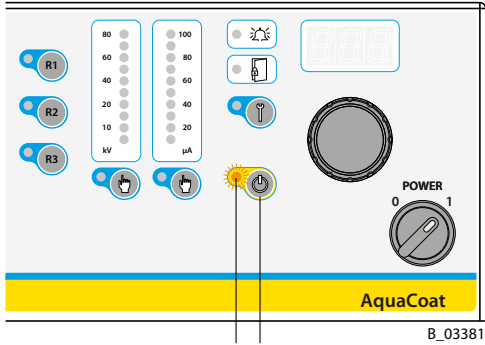

Procedure

1. Switch device to "Standby" by pressing the "Standby" key (3). The "Standby" LED (4) lights up yellow.

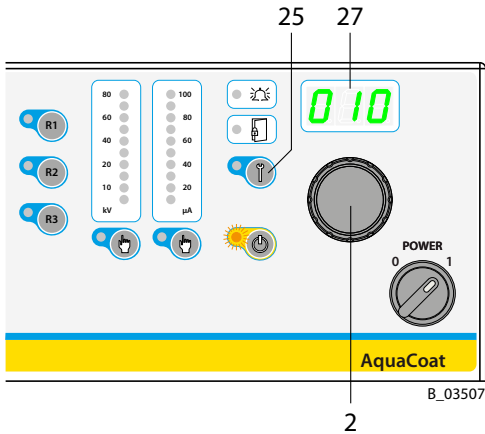

2. Press and hold the "Service" push button (25).
3. Turn the universal control dial (2) with the other hand until the LED display (27) shows the number "10". Then release the "Service" button (25). The running text "configuration" is displayed in the LED display (27). The device is now in configuration mode.

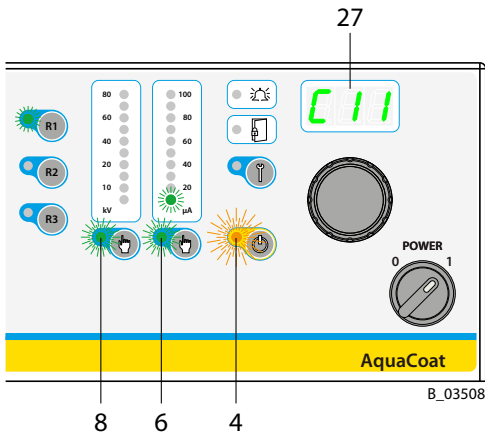

4. The first configuration parameter C11 is now displayed in the LED display (27). The two LED displays "Spray current" (6) and "High voltage" (8) flash at the same time. The "Standby" (4) LED display flashes quickly.

Note:

The C11 parameter can be changed, but this will not have any effect.



For ease of operation, the configuration settings are divided into three groups. The first group is for the end user; the other two groups, protected by a password, are reserved for WAGNER Service Department and the WAGNER production sites or the WAGNER Service Center, which have the necessary infrastructure.

- Group 1:
Parameters C11 to C20
(End user)
- Group 2:
Parameters C21 to C30
(WAGNER Service Department)
- Group 3:
Parameters C31 to C40
(Production plant, service center)

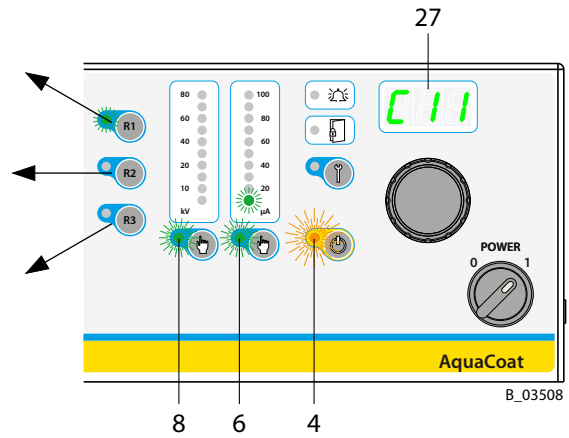

7.5.3 SETTING EXAMPLE: "PARAMETER C13"

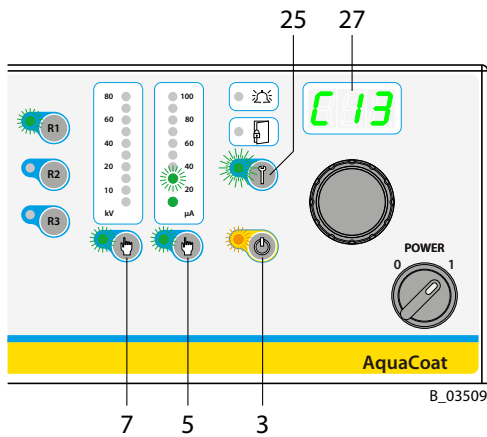

After getting started in configuration mode, the LED display (27) shows the parameter "C11" by default.

Selecting parameters

You can change to parameter "C13" by pressing the "Spray current" (5) or the "High voltage" (7) button.

Changing parameter values

To change a selected parameter value (e.g., C13), press push button "Service" (25). The content of the parameter is displayed in the LED display (27).

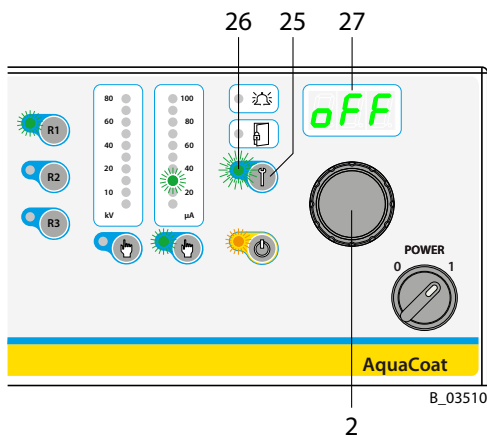

The flashing LED display "Service" (26) indicates that the parameter value "OFF" in the display (27) can be changed by the universal control dial (2). Possible values for parameter C13 are "on", "off" or "pro".

Saving a set parameter value

Press push button "Service" (25) for two seconds.

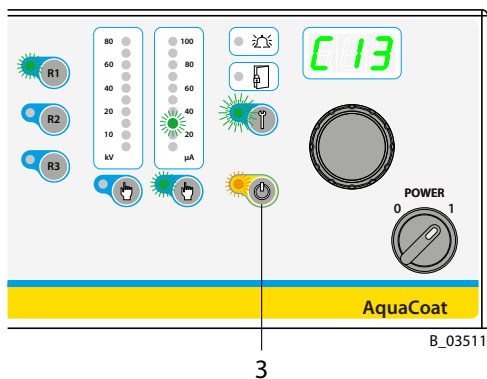

Returning to operation mode

Press the "Standby" key (3) to exit configuration mode.



7.6 EXTERNAL INTERFACE

The control unit is equipped with an interface. The electrical door switch is wired as standard at the 8-pin socket on the back of the VM 5020W control unit (also refer to the J3 plug in the block diagram, Chapter 5.5.5).

This socket also offers the functions designated in the following illustration.

→ Before using it, you have to select the respective parameters in the device configuration.

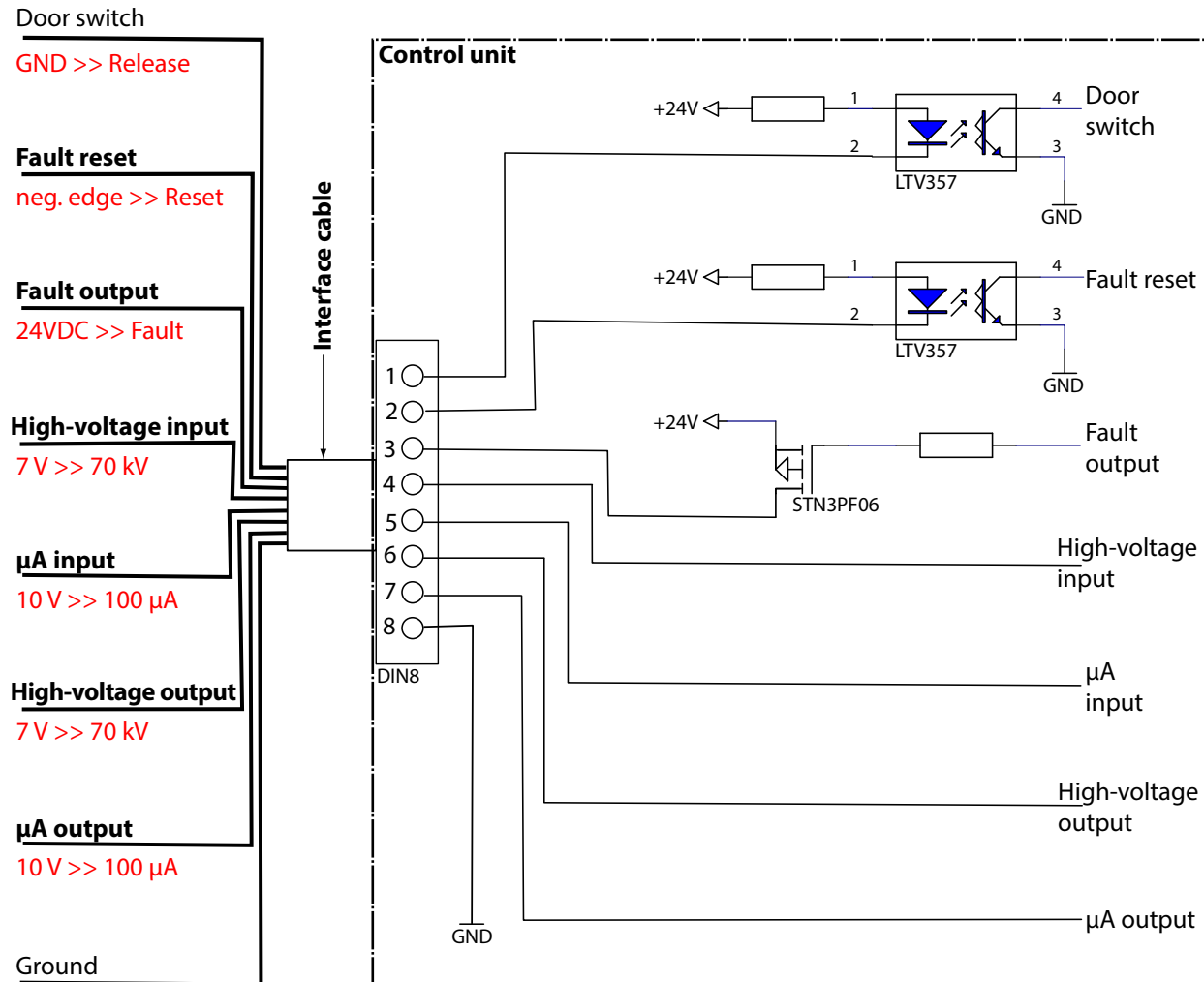
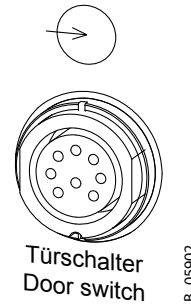

B_03415

Pin No.	Designation	Description
2 in	Fault reset	Potential-free contact (button) between pin 2 and pin 8 (ground) – If there is a fault, it can be acknowledged by pressing a button. – Acknowledgement is only given via the negative side.
3 out	Fault output	If there is a fault, +24 V DC is issued at pin 3 in reference to pin 8 (ground). → Maximum current 0.5 A
4 in *	DC kV in	Set value specification for high voltage. * Analog d.c. voltage input at pin 4 in reference to pin 8 (ground). → 0.1 V corresponds to 1 kV → 7.0 V is a maximum specification and corresponds to 70 kV
5 in *	DC μ A in	Set value specification for spray current limitation * Analog d.c. voltage input at pin 5 in reference to pin 8 (ground) → 0.1 V corresponds to 1 μ A → 10.0 V is a maximum specification and corresponds to 100 μ A
6 out	DC kV out	Output of current actual voltage. Analog d.c. voltage output at pin 6 in reference to pin 8 (ground). → 0.1 V corresponds to 1 kV → 7.0 V is a maximum specification and corresponds to 70 kV
7 out	DC μ A out	Output of current actual spraying current. Analog d.c. voltage output at pin 7 in reference to pin 8 (ground). → 0.1 V corresponds to 1 μ A → 10.0 V is a maximum specification and corresponds to 100 μ A

* If the external set value specification function will be used, parameter C12 must be set to "on" at the VM 5020W control unit (see Chapter [7.5.1](#)).

Analog output

→ The analog outputs are not power outputs, but merely **signal outputs**.

8 CLEANING AND MAINTENANCE

8.1 CLEANING

8.1.1 CLEANING STAFF

Cleaning work should be undertaken regularly and carefully by qualified and trained staff. They should be informed of specific hazards during their training.

The following hazards may arise during cleaning work:

- Health hazard from inhaling solvent vapors
- Use of unsuitable cleaning tools and aids

8.1.2 SAFETY INSTRUCTIONS

DANGER

Explosive powder/air mixes!

Danger to life and equipment damage.

- Before starting cleaning, rinsing, or other manual work, the high voltage must be shut down and locked to prevent it from being switched back on!
- The spray gun must be separated from the high-voltage supply before any cleaning work is started.
- Only electrically conductive tanks may be used for cleaning and flushing agents. Ground the tank.
- Preference should be given to non-ignitable cleaning and flushing agents.

If ignitable solvents are used:

- The cleaning and flushing agent's flash point must be at least 15 K above the ambient temperature.
- Ignitable solvents and solvent gases must be completely removed, before the system can be recommissioned.
- Ensure that no electric component is cleaned with or immersed into solvent.



NOTICE

Damage to electrical devices!

- Never immerse the spray gun in cleaning agent.

8.1.3 FLUSHING AND CLEANING THE SYSTEM

⚠ NOTICE

Liquid in air tube!

Functional faults caused by swollen seals.

Discharge current to ground → No high voltage.

- Always point the spray gun down when cleaning.
- Ensure that neither lacquers nor cleaning or flushing agent enters the air duct.
- When taking a break from work or when stored for a longer period, the spray gun should be positioned with the adapter pointing downwards.

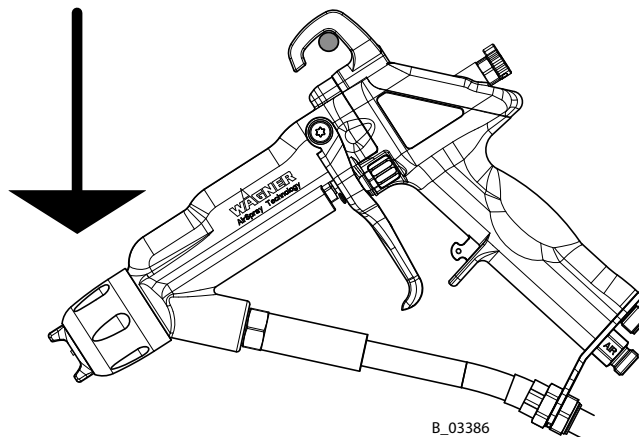

Flush regularly

- The AquaCoat spray system must be cleaned and rinsed out every day.
- The cleaning and flushing agents used must be compatible with the working material.

⚠ WARNING

Incompatibility of cleaning/flushing agent and working medium!

Risk of explosion and danger of poisoning by toxic gases.

- Examine the compatibility of the flushing and cleaning agents and working media on the basis of the safety data sheets.



Flushing procedures

1. Visual check: personal safety equipment, grounding and all devices ready to use.
2. Relieve the pressure of the product pressure generator and of the spray gun in accordance with Chapter 7.4.4.
3. Close atomizing air regulator.
4. Dismount nozzle and clean separately (see Chapter 7.4.6).
5. Connect the system to the flushing agent supply.
6. Open AquaCoat air inlet. Control unit remains switched off. Set product pressure.
7. Have the grounded metal collecting tray close by and open return valve.
8. Rinse until flushing agent flows from the return tube.
9. Close the return valve again.

10. Point the spray gun without nozzle into the grounded metal tank for return product.
11. Open the spray gun. Rinse until flushing agent flows from the spray gun.
12. Close the spray gun.
13. Clean and/or change the suction filter.
14. Repeat steps 7–13 if necessary.
15. Relieve pressure → Chapter [7.4.4](#).
16. Close pump pressure regulator. Switch on compressed air supply. Open atomizing air regulator.
17. Actuate the trigger of the spray gun and thoroughly blow out the air passages.
18. Switch off the compressed air supply.
19. Clean the gun body remaining AquaCoat components with a cleaning agent recommended by the lacquer manufacturer.
20. Dry with a cloth or a blow gun.
21. Remove flushing agent supply. Dispose of the contents of the tank for return product according to the local regulations.

8.1.4 DECOMMISSIONING

1. Flush and clean the system according to Chapter [8.1.3](#).
2. Fill the whole system with flushing agent in accordance with Chapter [5.6.2.1](#) and pump's operating manual.

8.1.5 LONG-TERM STORAGE

If storing the system for a prolonged period of time, thorough cleaning and corrosion protection are necessary. For the last rinse, replace the water or solvent in the product pumps with a suitable preservative.

Procedure:

1. Clean the system according to Chapter [8.1.3](#).
2. Fill the whole system with flushing agent in accordance with Chapter [5.6.2.1](#) and pump's operating manual.
3. Fill the whole system with preservative according to Chapter [5.6.2.1](#) and pump's operating manual. Observe the specifications of the lacquer manufacturer.
4. If the discharge duct is to be removed, seal product outlet with plug.
5. If the suction system is to be removed, seal product inlet with plug.
6. Storage according to Chapter [6.2](#).

8.2 MAINTENANCE

8.2.1 MAINTENANCE STAFF

Maintenance work should be undertaken regularly and carefully by qualified and trained staff. They should be informed of specific hazards during their training.

The following hazards may arise during maintenance work:

- Health hazard from inhaling solvent vapors
- Use of unsuitable tools and aids

An authorized person must ensure that the device is checked for being in a reliable state after maintenance work is completed.

8.2.2 SAFETY INSTRUCTIONS

DANGER

Incorrect maintenance/repair!

Danger to life and equipment damage.

- Only a WAGNER service center or a suitably trained person may carry out repairs and replace parts.
- Only repair and replace parts that are listed in the "Spare parts" chapter and that are assigned to the unit.
- Before all work on the device and in the event of work interruptions:
 - Relieve the pressure from the device.
 - Secure the spray gun against actuation.
 - Switch off the energy and compressed air supply.
 - Disconnect the control unit from the mains.
- Observe the operating and service manual for all work.



Prior to maintenance

- Flush and clean the system according to Chapter [8.1.3](#)

After maintenance

- Carry out safety checks in accordance with Chapter [8.2.3](#).
- Put the system into operation and check for leaks as described in Chapter [6.8](#).
- Carry out a function test, if required, in accordance with Chapter [11](#).
- Have the system checked for safe condition by an authorized person.

8.2.3 SAFETY CHECKS AND MAINTENANCE INTERVALS

8.2.3.1 GROUNDING CHECK

Every day

- Before starting work, carry out a visual check to ensure that the grounding connection is present in the AquaCoat cabinet and in all relevant components.

8.2.3.2 INSPECTION OF THE SAFETY ELEMENTS

Every day

- General visual inspection:
 - Check for damage or loose contacts:
 - Black grounding band in the cabinet door.
 - Black grounding bolt on the cabinet door (below),
 - Sealing joint for glass window (option).
 - Grounding switch on the RH side wall.
 - All cables and connections.

Monthly

- Door switch test:
 - Open cabinet door (pull hard).
 - Switch on the control unit.
 - Switch air on.
 - Actuate the trigger on the spray gun.
 - Electrical door switch test:
 - The high voltage must remain switched off.
 - The control unit displays error E30.
 - Pneumatic door switch test:
 - The grounding switch must remain closed (below).
- Grounding switch test:
 - Close cabinet door.
 - Switch on the control unit.
 - Acoustically ascertain switch movement.
 - Check that the cabinet door is locked.
 - Switch off control unit.
 - Acoustically ascertain switch movement.

8.2.3.3 FURTHER MAINTENANCE INTERVALS

Every day

- Check hoses, tubes and couplings: see Chapter [8.2.6](#)
- Flush and clean the spray gun in accordance with Chapter [8.1.3](#).

Weekly

- Check spray guns for damage.

Yearly or as required

- In accordance with DGUV regulation 100-500 Chapter 2.29 and Chapter 2.36:
 - The liquid ejection devices should be checked by an expert (e.g., WAGNER service technician) for their safe working conditions as required and at least every 12 months.
 - For shut down devices, the examination can be suspended until the next start-up.

8.2.4 CHANGING THE SPRAY GUN WITH HOSE SET

Example for ZIP52

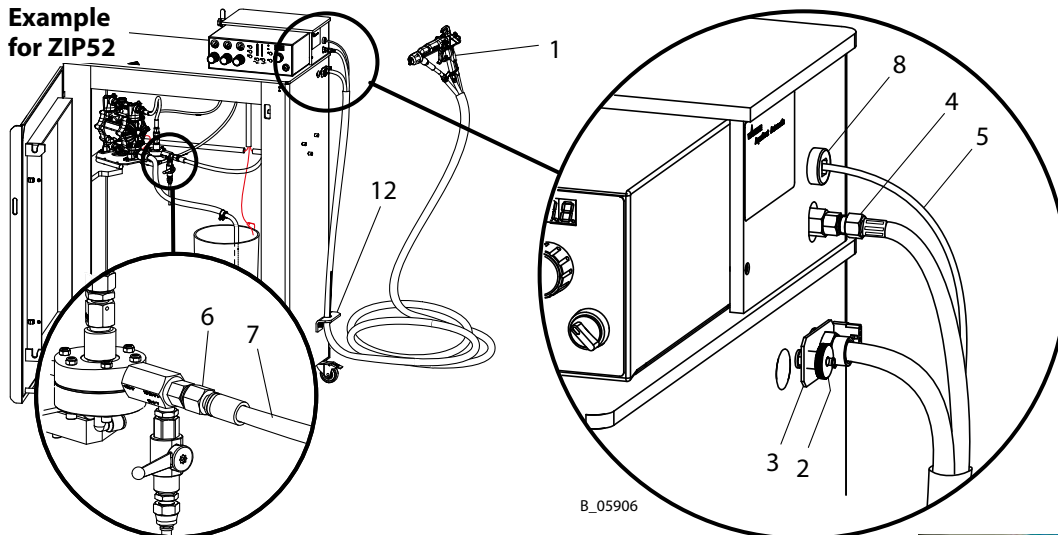

B_05906

Disassembly

1. Dismount the VM 5020W control unit in accordance with Chapter [10.5](#).
2. Rear of the control unit: Loosen the knurled nut on the gun cable (5) and remove plug.
3. Loosen the union nut (4) of the air hose at the AquaCoat cabinet.
4. Loosen the union nut (6) on the bared part of the product hose (7).
5. Unscrew knurled nut (2).
6. Carefully remove the gun (1) together with the hose set.

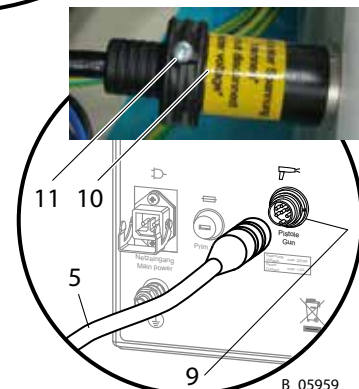

B_05959

Assembly

The GM 5020EAW spray gun can be combined with different hose sets. The available hose sets are listed in the accessories (Chapter [13.4](#)).

1. Push bared part of product hose approx. 1.25 m; 4.1 ft through the opening as far as the mounting plate.
2. Fasten mounting plate (3) to grounding screw with knurled nut (2).
3. Screw bared end of product hose (7) with union nut (6) to pump output and/or product pressure regulator.
4. Screw air hose (4) to the AquaCoat cabinet.
5. Remove protective sleeve (10), insert gun cable (5) through the bushing (8), place protective sleeve (10) again. Connect gun cable (5) to control unit (gun connection (9)). Secure with knurled nut. Push protective sleeve (10) over the knurled nut and gently fasten using screw (11). Attach strain relief grommet (8).
6. Fasten the hose set using hose holder (12).
7. Carefully push the VM 5020W control unit back again to the limit stop. Note the connecting lines and connecting cables at the back of the control unit!
8. Screw the VM 5020W control unit on the cabinet.

8.2.5 REPLACING THE PRODUCT HOSE AND/OR AIR HOSE

1. Loosen and unscrew clamping screw (1).
2. Loosen nut (2) and remove product hose from the attachment point.
3. Push protective hose (4) back.
4. Carefully remove product hose (3) from the protective hose (4).
5. Loosen union nut (5) at gun connection and carefully remove air hose (6) from the protective hose (4).

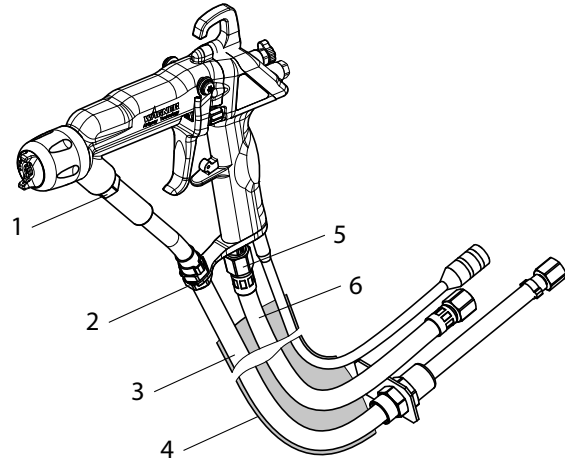

B_03389

8.2.6 PRODUCT HOSES, TUBES AND COUPLINGS

The service life of the complete hoses between product pressure generator and application device is reduced due to environmental influences even when handled correctly.

- Check hoses, pipes, and couplings every day and replace if necessary.
- Additionally, the operator must regularly check the complete hoses for wear and tear as well as for damage at intervals that he/she has set. Records of these checks must be kept.
- Undamaged complete hoses are to be replaced when one of the two following intervals has been exceeded:
 - 6 years from the date of the hose crimping (see fitting embossing).
 - 10 years from the date of the hose imprinting.

Fitting embossing (if present)	Meaning
xxx bar	Pressure
yymm	Crimping date (year/month)
XX	Internal code

Hose imprinting	Meaning
WAGNER	Name/Manufacturer
yymm	Date of manufacture (year/month)
xxx bar (xx MPa) e.g., 270 bar (27 MPa)	Pressure
XX	Internal code
DNxx (e.g., DN10)	Nominal diameter



9 TROUBLESHOOTING

9.1 FAULT DISPLAYS AT THE VM 5020W CONTROL UNIT

⚠ WARNING

Electric shock hazard inside the control unit!

Danger to life from electric shock.

- May only be installed/maintained by skilled electricians or under their supervision.
- Operation according to the safety regulations, fire protection and electrotechnical rules.
- Must be de-energized before work is commenced on active parts.

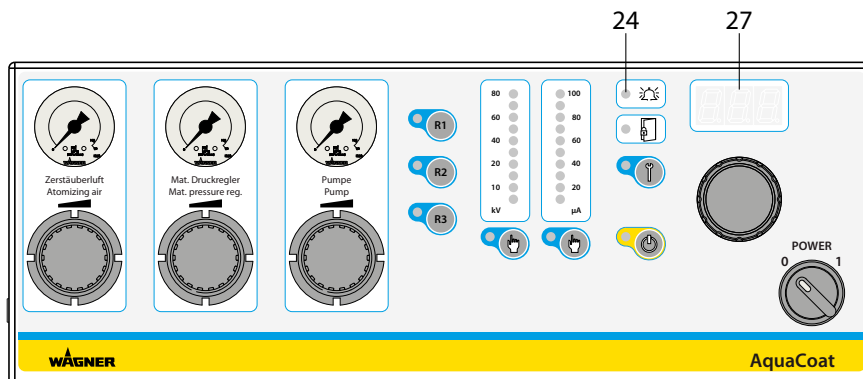

B_03506

Functional fault	Cause	Remedy
No illuminated display lights up.	<ul style="list-style-type: none"> – Mains supply not switched on. – Fuses defective. 	<ul style="list-style-type: none"> – Check and switch on mains supply. – Replace fuses. – Contact the WAGNER Service Department.
No high voltage.	<ul style="list-style-type: none"> – Spray gun cable not connected or defective. – Spray gun not connected or defective. 	<ul style="list-style-type: none"> – Connect spray gun cable. – Contact the WAGNER Service Department.
Malfunction LED (24) lights up. Fault message in display (27).	<ul style="list-style-type: none"> – See the following table. 	<ul style="list-style-type: none"> – See the following table.

OPERATING MANUAL



Faults are indicated by the "Fault" LED (24). In addition the error number is shown in the display (27). If a fault occurs, the high voltage is switched off immediately. The user can only continue to work once the fault has been remedied and acknowledged with push button "Service" (25).

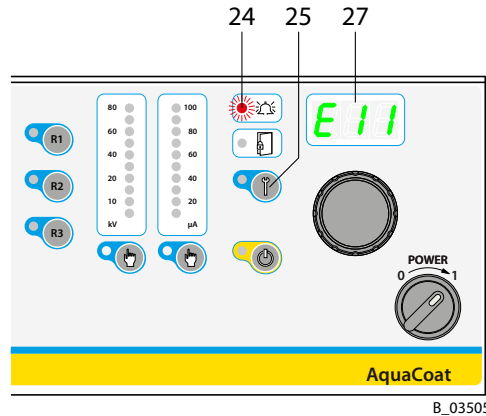

B_03505

Code display	Malfunction	Cause	Remedy
E11	Ground monitoring	<ul style="list-style-type: none"> – Grounding cable is interrupted. – Gun is not connected. 	<ul style="list-style-type: none"> – Check/replace gun cable. – Check/replace gun. – Connect gun.
E12	No coil current/cascade interrupt	<ul style="list-style-type: none"> – The cascade is not connected. – Cascade is interrupted → defective 	<ul style="list-style-type: none"> – Connect the cascade. – Check/replace cascade.
E13	Coil current too big	<ul style="list-style-type: none"> – The cascade is defective. 	<ul style="list-style-type: none"> – Check/replace cascade.
E21-E25	Exception error	<ul style="list-style-type: none"> – Hardware defect has occurred. 	<ul style="list-style-type: none"> – If problem persists, contact the WAGNER Service Department.
E30	Door switch	<ul style="list-style-type: none"> – Door open. – Door switch defective. 	<ul style="list-style-type: none"> – Close door. – Check/replace door switch.
E40-E43	Gun communication faulty	<ul style="list-style-type: none"> – Gun cable defective. – Operating unit of spray gun defective. – Control unit defective. 	<ul style="list-style-type: none"> – Check/replace gun cable. – WAGNER Service Department. – WAGNER Service Department.
E60	Password error	<ul style="list-style-type: none"> – Password not set. 	<ul style="list-style-type: none"> – Password to be set by Service Center.

9.2 FAULTS IN THE SYSTEM

Functional fault	Cause	Remedy
Insufficient product output	– Nozzle too small.	– Flat jet: Select larger nozzle (see nozzle table).
	– Product pressure too low.	– Increase product pressure.
	– Product viscosity too high.	– Thin spray product in accordance with the manufacturer's instructions.
	– Filter in paint supply clogged.	– Clean or replace filter.
	– Nozzle is clogged.	– Clean or replace nozzle.
	– Product valve travel set too small.	– Increase product valve travel by turning the adjusting screw.
Poor spray pattern	– Atomizing air incorrectly adjusted.	– Readjust atomizing air.
	– Unfavorable nozzle size.	– Select a different nozzle (see nozzle table).
	– The product viscosity is too high.	– Thin product in accordance with the manufacturer's instructions.
	– Product pressure too high/ too low.	– Adapt product pressure.
	– Damaged nozzle.	– Attach new nozzle.
Poor wrap-around	– Poor grounding at object.	– Check grounding of object or hanger with ohmmeter.
	– Lacquer resistance too high/too low.	– Check lacquer resistance (see Chapter 2.4).
	– Spraying pressure too high.	– Readjust spraying pressure.
No wrap-around	– No high voltage.	– Switch on high voltage using push button. – Connect gun and gun cable/check for defect. – Check lacquer resistance (see Chapter 2.4).
	– Seal in end piece defective.	– Repair by WAGNER Service Department.
	– Air-passages damp.	– Clean and dry air passages.
	– Object not grounded.	– Check grounding.
Back-spray	– Distance between spray gun and work piece too large.	– Reduce distance between spray gun and work piece.
	– High voltage set wrongly (too high).	– Adapt high voltage to product.
	– Loosen the nozzle union nut for round jet method.	– Slightly tighten union nut by hand.
	– Valve seat leaks, valve seat or valve tip worn	– Replace valve seat or valve tip.
Product emission at nozzle when the gun is closed	– Valve rod packing leaks/ damaged	– Replace the packing (see Chapter 10).

10 REPAIRS

10.1 REPAIR STAFF

Repair work should be undertaken carefully by qualified and trained personnel. They should be informed of specific hazards during their training.

The following hazards may arise during repair work:

- Health hazard from inhaling solvent vapors
- Use of unsuitable tools and aids

A skilled person must check to ensure that the device is in a reliable state after it is repaired. Carry out function test in accordance with Chapter [11](#).

10.2 SAFETY INSTRUCTIONS

Before a Repair

- Flush and clean the system → Chapter [8.1.3](#).

DANGER

Incorrect maintenance/repair!

Danger to life and equipment damage.

- Only a WAGNER service center or a suitably trained person may carry out repairs and replace parts.
- Only repair and replace parts that are listed in the "Spare parts" chapter and that are assigned to the unit.
- Before all work on the device and in the event of work interruptions:
 - Relieve the pressure from the device.
 - Secure the spray gun against actuation.
 - Switch off the energy and compressed air supply.
 - Disconnect the control unit from the mains.
- Observe the operating and service manual for all work.



After a Repair

- Carry out safety checks in accordance with Chapter [8.2.3](#).
- Put the system into operation and check for leaks as described in Chapter [6.8](#).
- Function test in accordance with Chapter [11](#).
- In accordance with DGUV regulation 100-500 Chapter 2.29 and Chapter 2.36:
 - The liquid ejection devices should be checked by an expert (e.g., WAGNER service technician) for their safe working conditions as required and at least every 12 months.
 - For shut down devices, the examination can be suspended until the next start-up.

10.3 MOUNTING MATERIALS

In Chapter 14 the order numbers for device spare parts can be found, as well as for wearing parts such as seals.

→ Use torques, greases and glues in accordance with Chapter 14. Spray gun in accordance with Chapter 10.4.

Mounting materials

Order No.	Quantity	Designation	Smaller tanks
9992511	1 pc \triangleq 50 ml	Loctite® 243	
9992831	1 pc \triangleq 50 ml	Loctite® 542	
9992528	1 pc \triangleq 150 g	Loctite® 270	
9992616	1 pc \triangleq 1 kg can	Molykote® DX grease	50 g tube \triangleq Order No. 2355419
9992698	1 pc \triangleq 200 g can	Vaseline white, PHHV II	
353702	10 ml; 10 cc	High-voltage oil	

Brand notice

The brands specified in this document are property of the respective owners. Loctite®, for example, is a registered brand of Henkel.

10.4 SPRAY GUN

Plastic parts

Gently handle all plastic parts.

10.4.1 TOOLS

For disassembling and assembling the spray gun, the following tools are required:

- Allen wrench, SW 2
- Allen wrench, SW 3
- Allen wrench, SW 5
- Wrench, SW 5
- Wrench, SW 6
- Wrench, SW 8
- Wrench, SW 11
- Wrench, SW 12
- Wrench, SW 14
- Wrench, SW 19
- Ring spanner, SW9
- Ring spanner, SW11
- Torx® wrench 20
- Torx® wrench 25
- Screwdriver No. 1
- Slide gauge
- Valve needle assembly tool, Order No. 2309368
- Clamping screw assembly tool, Order No. 2325263

Only as required:

- Handle seal assembly tool (Order No. 2342334, not included in scope of delivery)

10.4.2 DISMANTLING OF THE SPRAY GUN

1

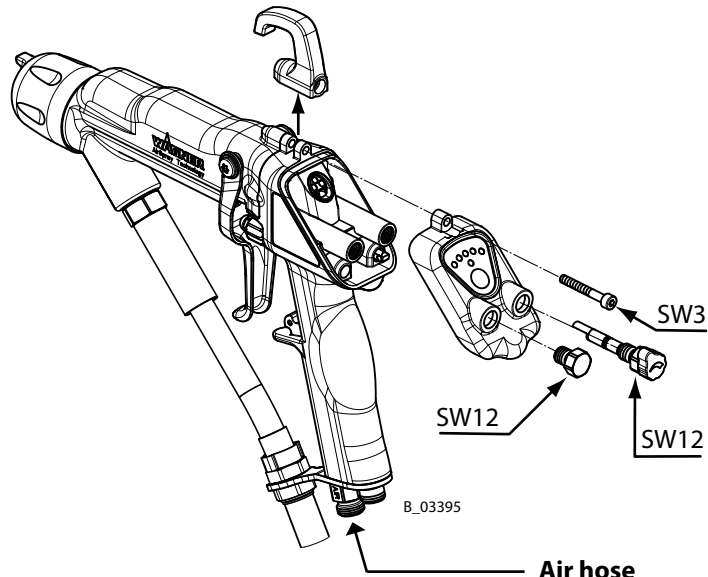

Air hose

When unscrewing the air hose, a second open-ended/box wrench must be used for bracing.

2

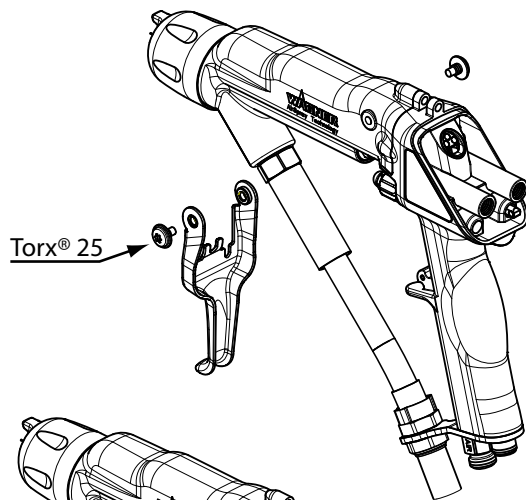

3

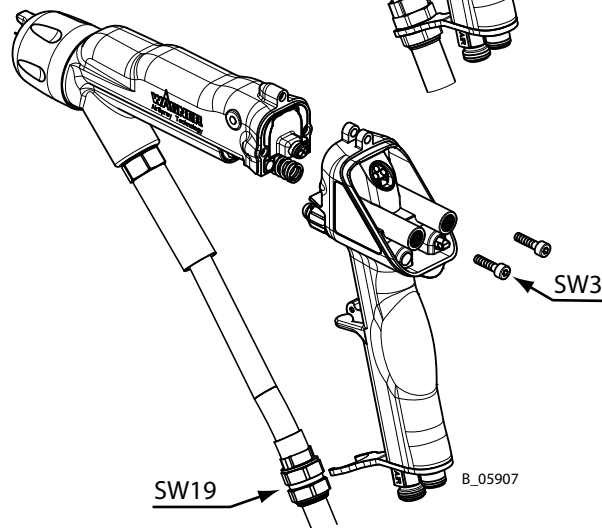

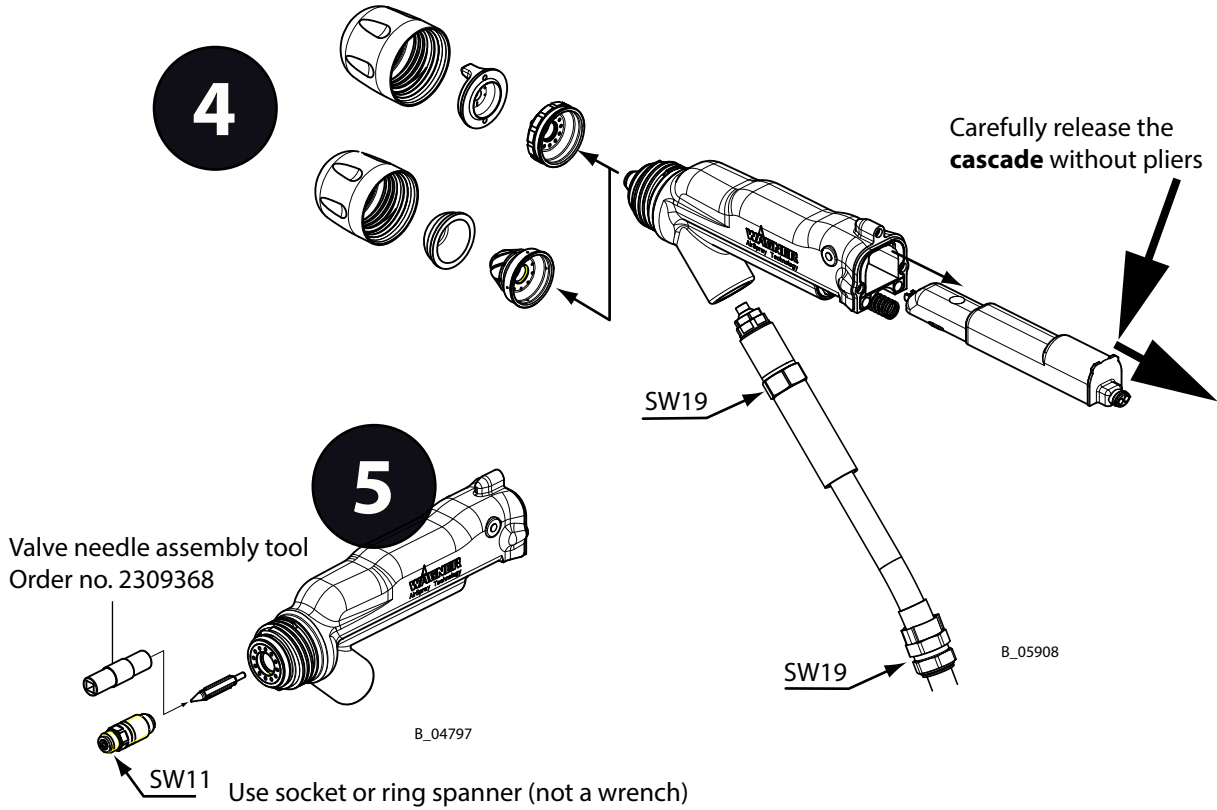

Valve needle Air

Loosen valve tip by hand using the valve needle assembly tool (Order No. 2309368).

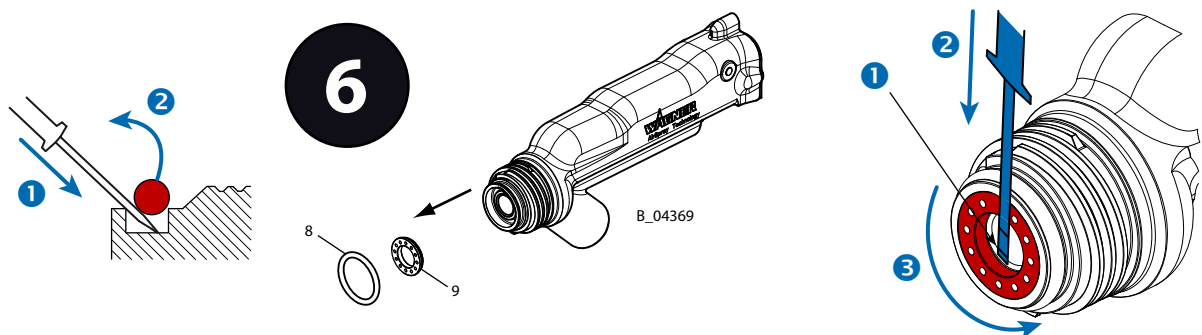

O-ring (8): 1.

Use screwdriver no. 1 to press under the O-ring.
2. Lever up the O-ring and remove it.

Air distribution (9): 1.

Locate the start of the thread for recessed internal threading.
2. Lever under the air distribution ring directly in front of the start of the thread using screwdriver no. 1.
3. As soon as the ring disengages, carefully undo it on all sides.

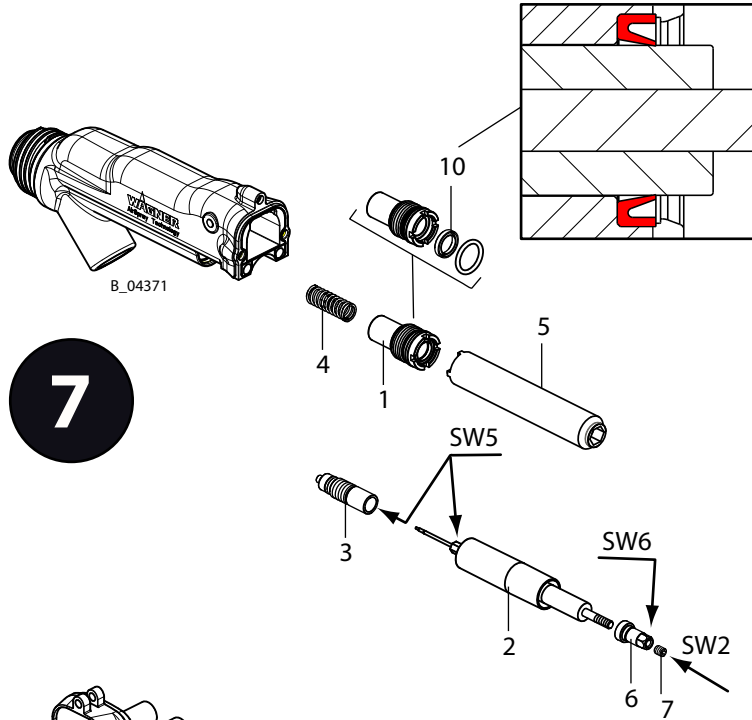

1. Remove pressure spring (4).
2. Loosen clamping screw (1) with assembly tool (5).
3. Unscrew valve rod unit (2, 6, 7). The packing (3) is also unscrewed and removed.
4. **Only as required:** Remove rod seal (10). Do not damage the housing in the process.

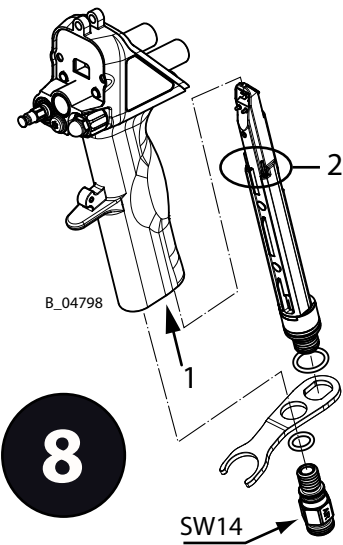

Two gold contact sleeves either remain in the handle (1) or are seated on the two gold pins (2). Do not lose!

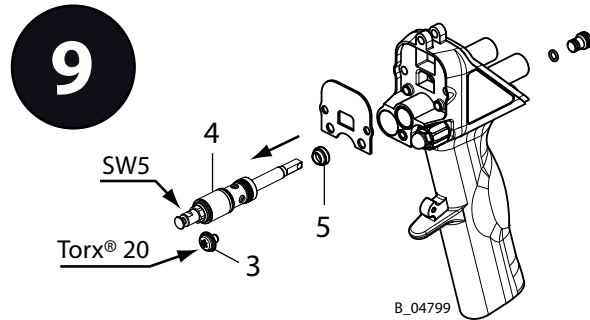

1. Loosen the oval head screw (3).
2. Pull the air valve (4) out off the drilled hole. Do not turn! Do not damage the cylindrical surfaces. Ideally press on the tappet from behind using a transversely held screwdriver, for example.
3. **Only as required:** Press out seal (5) using a handle seal assembly tool (Order No. 2342334, not included in scope of delivery)

10.4.3 CLEANING THE PARTS AFTER DISASSEMBLY

Please note:

- All reusable parts (except for the electrical components) should be cleaned thoroughly using a suitable cleaning agent.
- The adapter, plug, inside handle and all dismantled parts must be clean and dry after cleaning. Care should be taken that these parts remain free of solvents, grease or sweat from the hands (salt water). Clean and mount wearing gloves.
- Spare parts may have safety-relevant properties.
Only repair and replace parts that are listed in the "Spare parts" chapter and that are assigned to the unit.
- Defective parts, O-rings and seal sets must always be re-placed.

 **WARNING**

Incompatibility of cleaning agent and working medium!

Risk of explosion and danger of poisoning by toxic gases.

- Examine the compatibility of the cleaning agents and working media on the basis of the safety data sheets.



In Chapter [14](#) the part numbers for gun spare parts can be found as well as for wearing parts such as seals.



10.4.4 ASSEMBLING THE SPRAY GUN

Mounting materials		
Pos	Order No.	Description
2 *	9992698	Vaseline white, PHHV II
4	9992511	Loctite® 243

* Use Vaseline sparingly

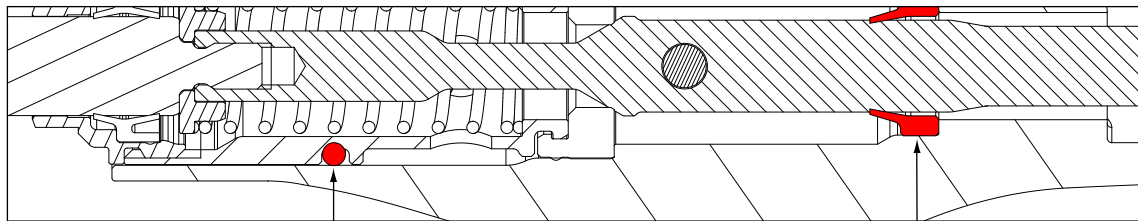

1

Only as required
(if the seal was removed):
press in using handle
seal assembly tool
(Order No. 2342334, not
included in scope of
delivery)

2

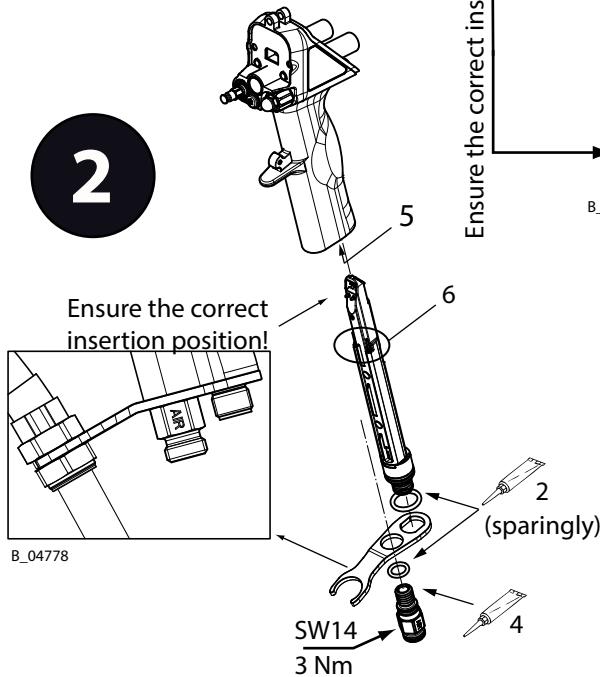

Ensure the correct insertion position!

B_03448

Recess for pin
Hold the air valve so that
the pin points to the left.

Gold contact sleeves
Check whether the two gold contact sleeves are
in the handle (5). Otherwise, insert the sleeves
onto the two gold pins of the plug (6). Slide plug
into handle.

B_04778



3

Valve rod unit

Set length adjusting measure X with withdrawal nut (7) and then fasten the threaded pin (6) using an Allen wrench SW2.

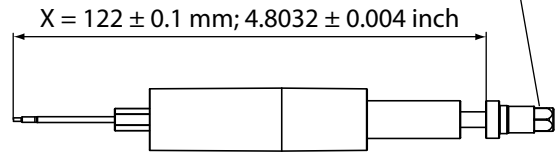
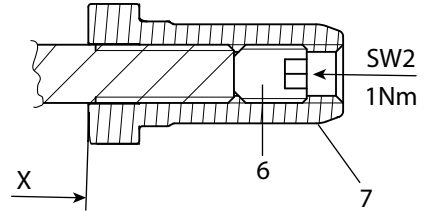

B_04791

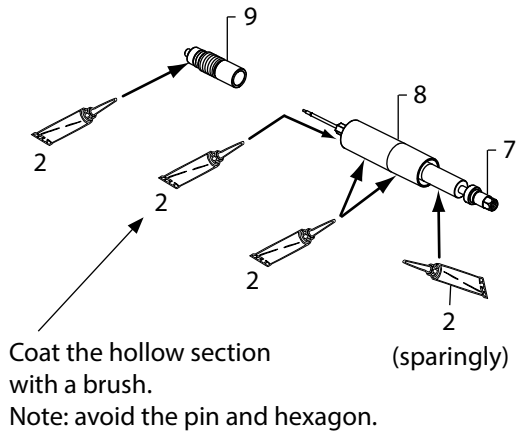

Wear gloves!

The outside thread of the packing (9) must be free of lacquer.

Valve rod unit (8) and packing (9):

- grease,
- slide together,
- screw together (10).

Grease clamping screw (1) and mount using assembly tool (5).

Insert spring (4).

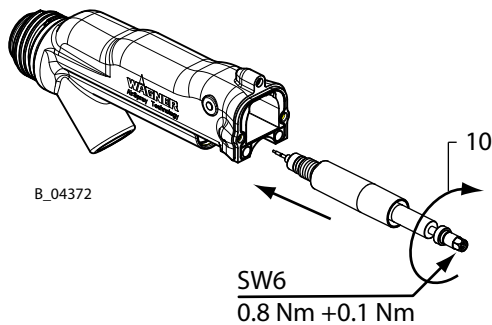
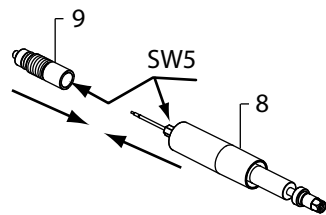

B_04372

Only as required (if the rod seal was removed):

Press in rod seal (11). In the process, press only on the lowest area of the rod seal.

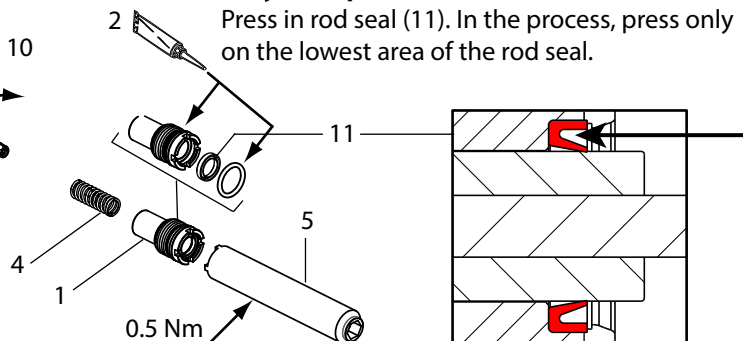

OPERATING MANUAL

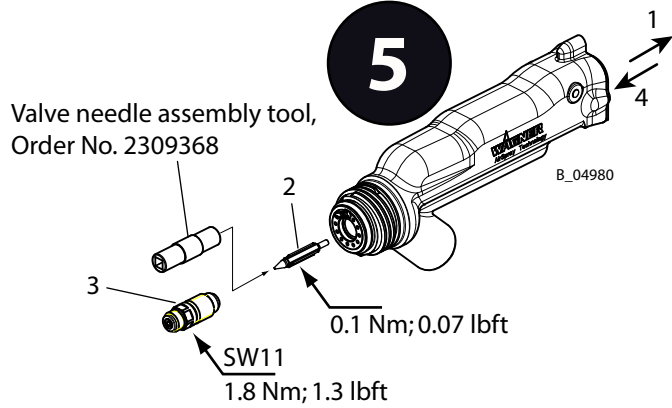
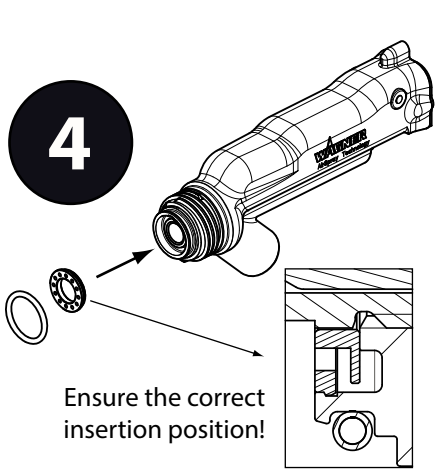

1. Move the valve rod to the rear position so that the sealing area does not become scratched (1).
2. Very slightly tighten valve tip (2) using an assembly tool with three fingers.
3. Use socket or ring spanner (no wrench) to tighten the valve housing (3).
4. Slide the valve rod to the forward position (at the valve seat) (4).



Clean and degrease the inside of the adapter and the cascade, then grease the cascade surface with Vaseline.

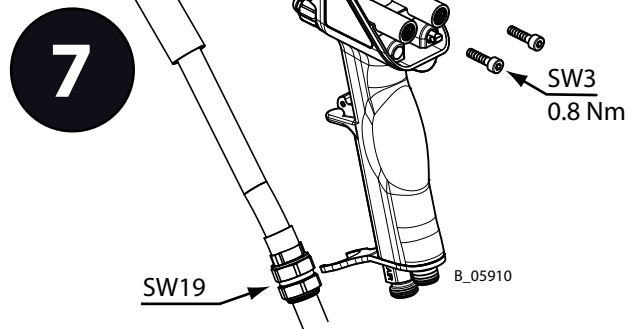
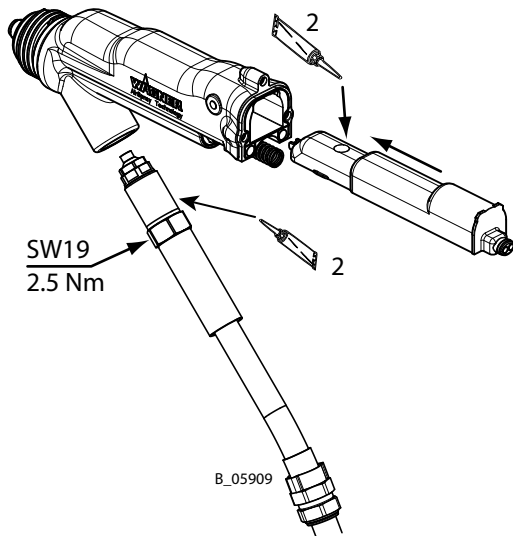

Ensure that the spring is inserted in the adapter.
Ensure that the flat gasket is inserted in the handle.

OPERATING MANUAL



8

Push the trigger upward into the air valve piston. The recess in the trigger must engage correctly in the indentation of the piston.

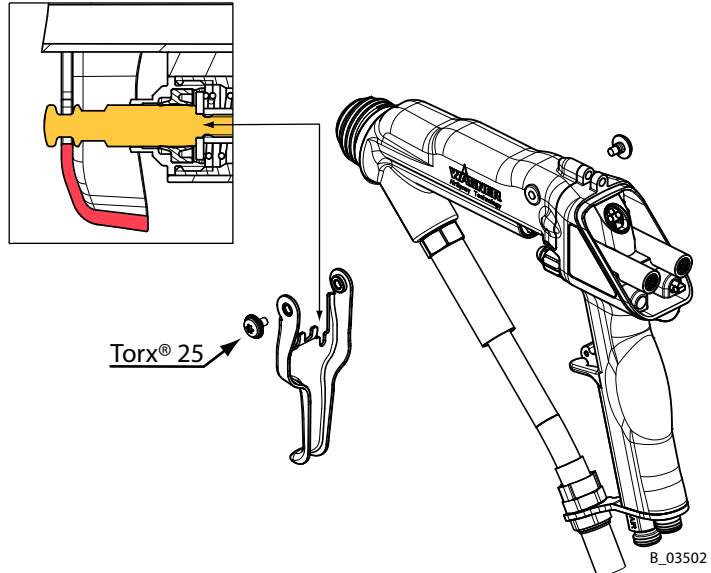

9

Cover (5)
The cover must be handled carefully and not be twisted or distorted in any way.

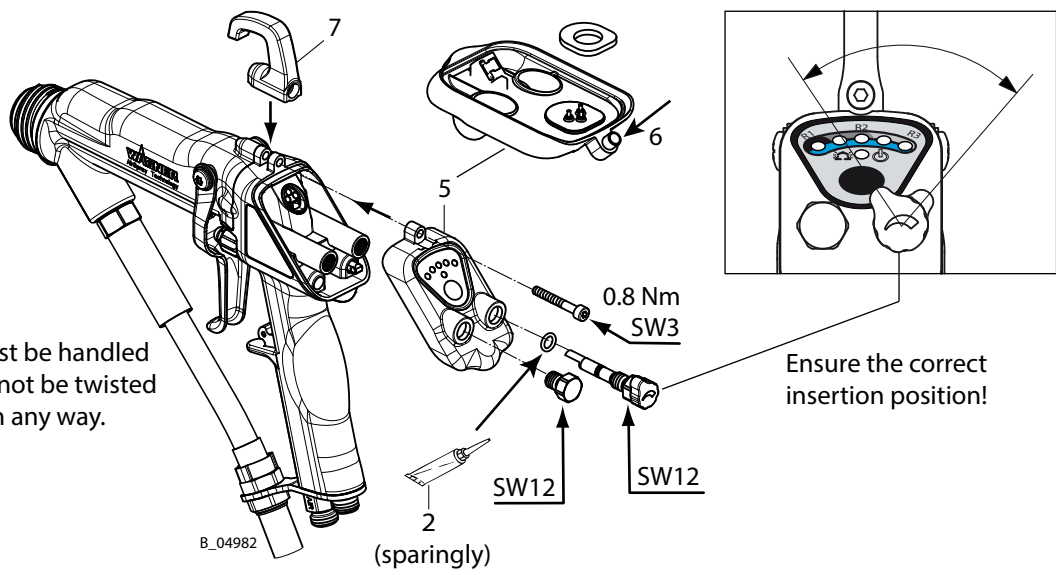

1. Press metal sleeve (6) back in cover (5) (e.g., press on table). In the process, only exert counter pressure on the sleeve bracket and not on the entire cover.
2. Position cover straight and level, and carefully press in. Use only minimal force, gently rocking from side to side if necessary.
3. Ensure that the cover is flush mounted on all sides.
4. Press back on metal sleeve for a flush fit (e.g., press on table).
5. Position bracket (7).
6. Mount screw, plug, and air regulation.



10

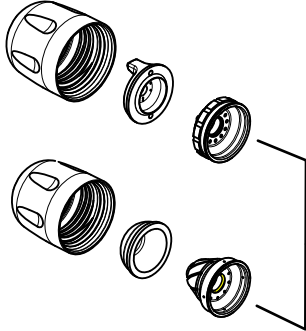

Flat jet nozzle

Diverse nozzle sizes, see Chapter [13.3](#).

Round jet nozzle

AWR 5000:
Diverse nozzle sizes, see Chapter [13.2.2](#).

EAWRV 5000:
see Chapter [13.2.1](#)

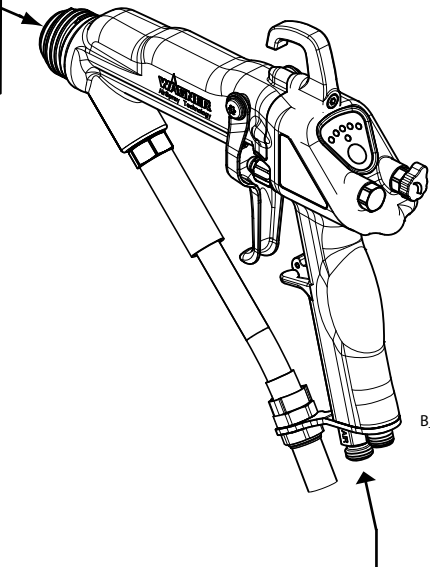

Air hose

When screwing on the air hose, a second open-ended/ring spanner must be used for bracing.

10.5 DISASSEMBLING VM 5020W CONTROL UNIT

1. Switch off control unit.
2. Open cabinet door (1) (pull hard).
3. Lock the compressed air supply and decompress the system.
4. Loosen and unscrew screws (2).
5. Carefully remove control unit (3) forwards. Note the connecting lines and connecting cables at the back of the control unit!

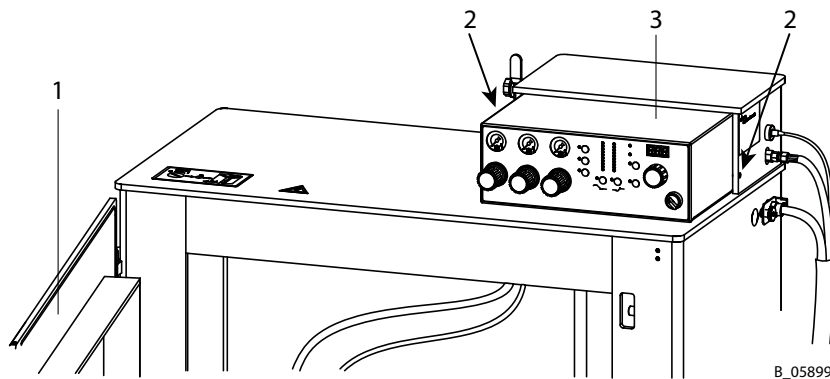

10.6 OPENING THE CONTROL UNIT

1. Dismount the control unit from the AquaCoat system (see Chapter 10.5).
2. Place control unit on a suitable surface.
3. Loosen and unscrew screws (1).
4. Remove cover (2) from housing.
5. When the repair is complete, replace the cover (2) on the housing and fasten with the screws (1).
→ Attention: Connect the grounding cable to the cover.

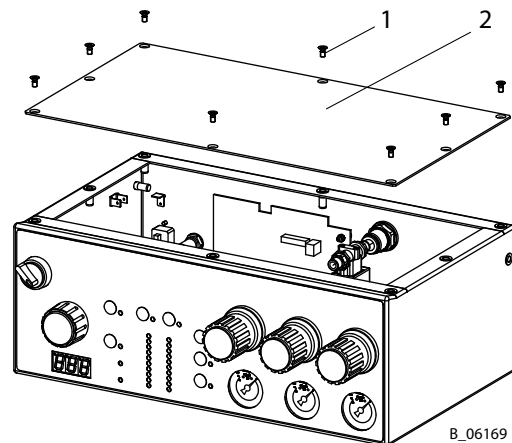

11 FUNCTION TEST AFTER THE REPAIR

After all repairs, the AquaCoat system must be checked for safe condition before recommissioning. The necessary scope of inspection and testing depends on the repair carried out and must be documented by the repair staff.

The system must not be filled with liquid for this function check.

Activities	Aid tools
1. Check connections <ul style="list-style-type: none"> – Check all product screw connections. – Check all air connections. – All electrical cables must be firmly secured. 	Visual check
"Safety-relevant check" 2. Check grounding connection <ul style="list-style-type: none"> – Measure resistance between grounding terminal and: <ul style="list-style-type: none"> – Handle of the gun (metal connections) – Pneumatic door switch – Product hose connection – Grounding switch → Set value: respective maximum 10 Ω. – Check visually the black grounding band in the cabinet door including the black grounding bolt. 	Multimeter
"Safety-relevant check" 3. Check potential equalization <ul style="list-style-type: none"> – Measure resistance between leakage resistance and: <ul style="list-style-type: none"> – Grounding point – Pump support – Potential equalization line at the pump – Connection terminal for product tank → Set value: respective maximum 10 Ω. 	Multimeter
4. Connect the device <ul style="list-style-type: none"> – Connect grounding cable. – Main tap closed. – Connect air supply (mains pressure 0.8 MPa; 8 bar; 116 psi). – Connect the mains. 	
5. Adjust alarm horn (only for level indication with alarm horn) <ul style="list-style-type: none"> – Loosen control unit and remove from mounting (see Chapter 10.5). – Switch air on. – Set alarm horn regulator to normal volume. – Switch air off and remount control unit in cabinet. 	Hexagon socket wrench 3 mm; 0.12 inches

Activities	Aid tools
6. Check door switch <ul style="list-style-type: none"> - Open the cabinet door. - Switch on the control unit. - Switch air on. - Actuate the trigger on the spray gun. → Electrical door switch test: <ul style="list-style-type: none"> - The high voltage must remain switched off. - The control unit displays error E30. → Pneumatic door switch test: <ul style="list-style-type: none"> - The grounding switch must remain closed (below). 	
7. Test grounding switch <ul style="list-style-type: none"> - Close cabinet door. - Air tap closed. - Remove gun → The "High-voltage" LED illuminates. - Voltage indicator 0 kV. - Current 80-100 μA. 	
8. Test door lock <ul style="list-style-type: none"> - Main switch off. - Air on. - Main switch on → Door locked. - Main switch off → Door unlocked. 	
9. Test spraying <ul style="list-style-type: none"> - Close cabinet door. - Main switch on. - Set high voltage to 5 kV. - Remove gun. - With the gun removed, gradually increase the high voltage up to maximum voltage (70 kV). → The spray current must not exceed 50 μA. - Main switch off. 	

11.1 FUNCTION TESTS FOR SPRAY GUN

11.1.1 AIR TESTS

Connect test or air hose to spray gun.

The following air tests are to be carried out twice each:

- at 0.1 MPa; 1 bar; 14.5 psi
- at 0.8 MPa; 8 bar; 116 psi

Checking the air valve

The air valve must switch on and off correctly.

Air seal

Without activating the trigger, test for air seal at the points marked in the illustration.

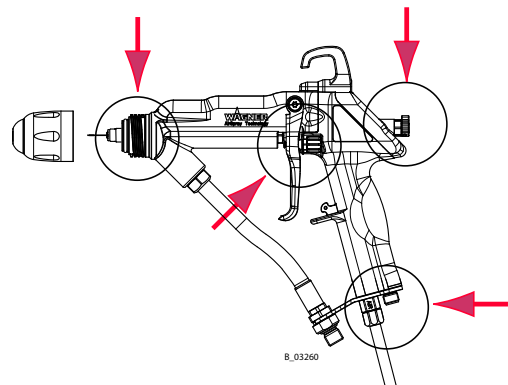

11.1.2 PRODUCT PRESSURE TEST

Connect the product hose to the spray gun.

Test the seal of the spray gun with suitable medium (e.g., flushing agent or Marcol 52) and a maximum pressure of 0.8 MPa; 8 bar; 116 psi. Increase the pressure gradually while doing so.

Observe the following gun components:

Product connection, nozzle body, product valve (no post-spraying).

DANGER

Exploding gas / air mixture!

Danger to life from flying parts and burns.

- Never spray into a closed tank.
- Ground the tank.



11.1.3 CHECK SPRAY PATTERN

Check spray pattern in accordance with Chapter [7.4.2](#).

12 DISPOSAL

When the equipment must be scrapped, please differentiate the disposal of the waste materials.

The following materials have been used:

- Steel
- Aluminum
- Elastomers
- Plastics

ⓘ NOTICE

Do not dispose of used electrical equipment with household refuse!

In accordance with European Directive 2012/19/EU on the disposal of used electrical equipment and its implementation in national law, this product may not be disposed of with the household refuse, but must be recycled in an environmentally correct manner.

- WAGNER or one of our dealers will take back your used WAGNER electric or electronic equipment and will dispose of it for you in an environmentally-friendly way.
- Please contact one of our service points, one of our representatives or us directly.

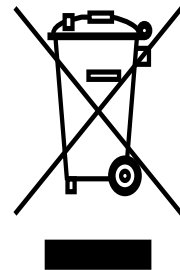



Consumable products

Consumable products (lacquers, adhesives, flushing and cleaning agents) must be disposed of in accordance with all applicable legal requirements.

13 ACCESSORIES

13.1 VALVE SEATS/VALVE TIPS

Order No.	Designation		
2312179	Valve seat Air, complete (steel)	Standard	 B_03697
2312176	Valve seat Air, complete (PEEK)		
2312187	Valve tip EAW, complete (PEEK)	Standard	 B_03517
2312188	Valve tip EAW, complete (steel)		

13.2 ROUND SPRAY NOZZLES

13.2.1 ADJUSTABLE EAWRV 5000 ROUND JET NOZZLE

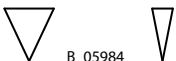
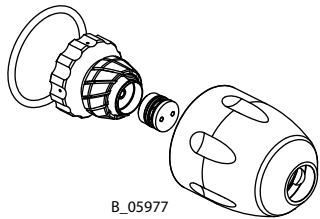
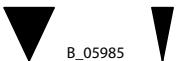

Order No.	Designation	Markings on union nut	
2366998	Nozzle set, EAWRV 5000 LV suitable for low viscosity products	 B_05984	 B_05977
2366997	Nozzle set, EAWRV 5000 HV suitable for high viscosity products	 B_05985	

Mounting tool

353210	Air nozzle spanner	 B_00117
--------	--------------------	--------------------------------------------------------------------------------------------------

For spare parts, see Chapter [14.5.2](#).

13.2.2 AWR 5000 AIR CAPS AND NOZZLES

Order No.	Designation	
2310557	Air cap, AR 5000 (D8)	 B_03239
2315049	Air cap, AR 5000 (D12)	
2310559	Nozzle, AWR 5000 (D8)	 B_03238
2315051	Nozzle, AWR 5000 (D12)	

Union nut: see Chapter [14.4](#)



13.2.3 DISCHARGE QUANTITY MEASUREMENTS WITH LACQUER

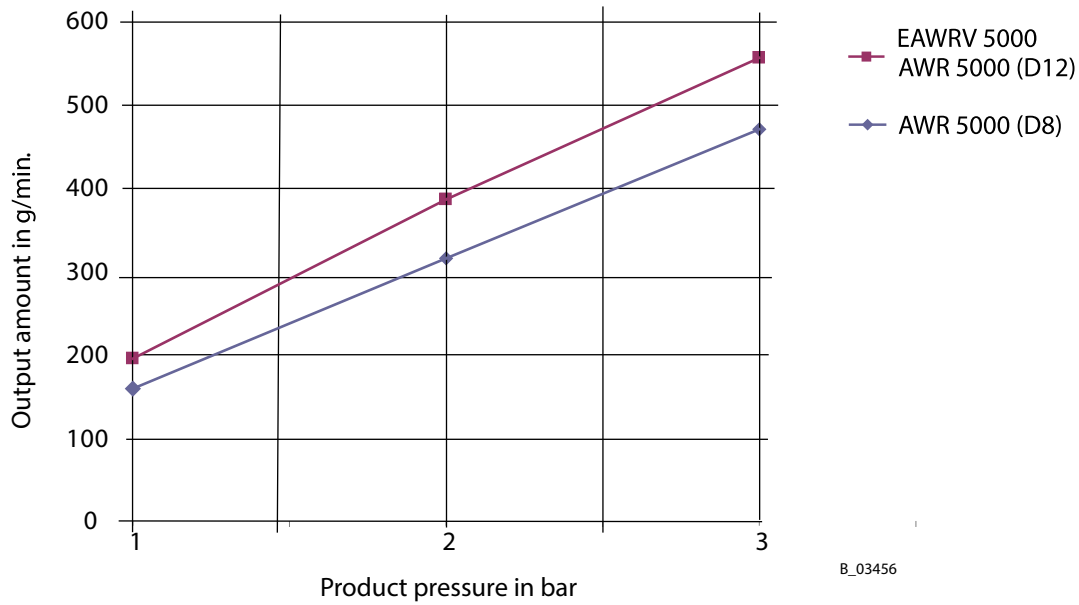

Device: GM 5020EAW/round jet nozzle
Viscosity: 22 DIN/4 seconds
Product hose: - Length 7.5 m; 24.6 ft
 - Inside diameter 6 mm; 0.24 inches



B_03456

13.3 FLAT JET NOZZLES

13.3.1 AF 5000 AIR CAPS

Order No.	Designation	
2310506	Air cap, AF 5000–0.4–0.8S	 B_03240
2310507	Air cap, AF 5000–1.0–1.4S	
2310508	Air cap, AF 5000–1.6–2.0S	
2314255	Air cap, AF 5000 – 0.4–0.8W (wide)	 B_03240
2314256	Air cap, AF 5000 – 1.0–1.4W (wide)	
2314258	Air cap, AF 5000 – 1.6–2.0W (wide)	

13.3.2 AF 5000 FLAT JET NOZZLES

Order No.	Designation	
2371036	Nozzle, AF 5000–0.3 mm (white)	 B_03241
2310538	Nozzle, AF 5000–0.4 mm (blue)	 B_03241
2310539	Nozzle, AF 5000–0.6 mm (black)	 B_03241
2310540	Nozzle, AF 5000–0.8 mm (yellow)	 B_03241
2310541	Nozzle, AF 5000–1.0 mm (red)	 B_03241

Order No.	Designation	
2310542	Nozzle, AF 5000–1.2 mm (green)	 B_03241
2310543	Nozzle, AF 5000–1.4 mm (brown)	 B_03241
2310544	Nozzle, AF 5000–1.6 mm (white)	 B_03241
2310545	Nozzle, AF 5000–1.8 mm (blue)	 B_03241
2310546	Nozzle, AF 5000–2.0 mm (black)	 B_03241



13.3.3 DISCHARGE QUANTITY MEASUREMENTS WITH LACQUER

Device: GM 5020EAW F/flat jet nozzle

Viscosity: 22 DIN/4 seconds

Product hose: - Length 7.5 m; 24.6 ft
 - Inside diameter 6 mm; 0.24 inches

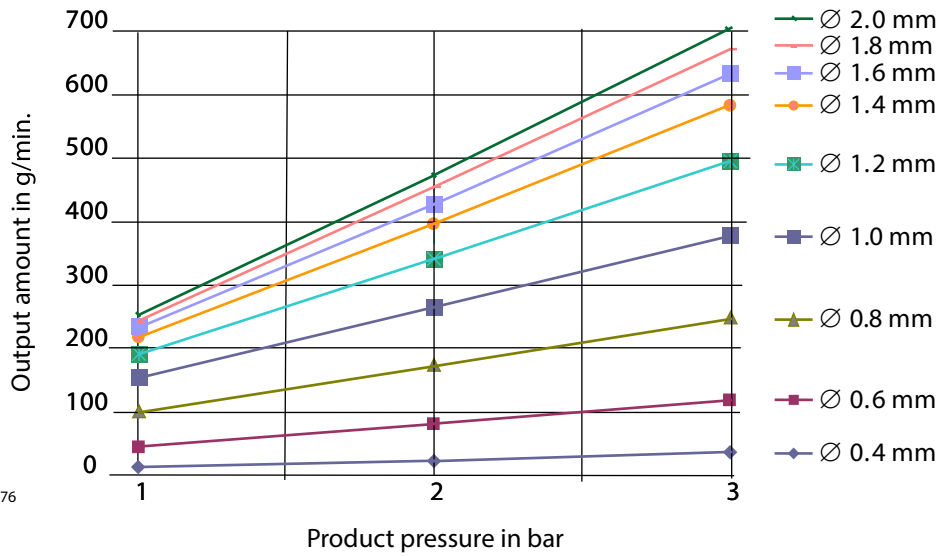

B_04776

OPERATING MANUAL



13.4 HOSES AND CABLES

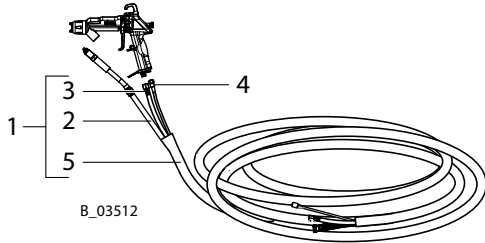

Note:

Product hose		
Inside diameter	DN 6	DN 3
Product	FEP	
Nominal pressure	2 MPa; 20 bar; 290 psi	

7.5 m; 24.6 ft			DN 6	DN 3
Pos	Stk	Designation	Order No.	Order No.
1	1	Hose set, GM 5000EAW (7.5 m; 24.6 ft)	2339183	2363105

Consists of:

2	1	Product hose, complete EACW (7.5 m; 24.6 ft)	2309907	2363037
3	1	Air hose, complete DN 8 (7.5 m; 24.6 ft)	2345336	
4	1	Gun cable, GM 5000E (7.5 m; 24.6 ft)	2339156	
5	8 m	Protective hose mesh, PP30 (8 m; 26.2 ft)	3676437	

10 m; 32.8 ft			DN 6	DN 3
Pos	Stk	Designation	Order No.	Order No.
1	1	Hose set, GM 5000EAW (10 m; 32.8 ft)	2339184	2363106

Consists of:

2	1	Product hose, complete EACW (10 m; 32.8 ft)	2309909	2363038
3	1	Air hose, complete DN 8 (10 m; 32.8 ft)	2345337	
4	1	Gun cable, GM 5000E (10 m; 32.8 ft)	2339157	
5	10.5 m	Protective hose mesh, PP30 (10.5 m; 34.4 ft)	3676437	

15 m; 49.2 ft			DN 6	DN 3
Pos	Stk	Designation	Order No.	Order No.
1	1	Hose set, GM 5000EAW (15 m; 49.2 ft)	2339185	2363107

Consists of:

2	1	Product hose, complete EACW (15 m; 49.2 ft)	2309910	2363039
3	1	Air hose, complete DN 8 (15 m; 49.2 ft)	2345338	
4	1	Gun cable, GM 5000E (15 m; 49.2 ft)	2339158	
5	15.5 m	Protective hose mesh, PP30 (15.5 m; 50.8 ft)	3676437	

20 m; 65.6 ft			DN 6	DN 3
Pos	Stk	Designation	Order No.	Order No.
1	1	Hose set, GM 5000EAW (20 m; 65.6 ft)	2339186	2363108

Consists of:

2	1	Product hose, complete EACW (20 m; 65.6 ft)	2309911	2363040
3	1	Air hose, complete DN 8 (20 m; 65.6 ft)	2345339	
4	1	Gun cable, GM 5000E (20 m; 65.6 ft)	2339159	
5	20.5 m	Protective hose mesh, PP30 (20.5 m; 67.2 ft)	3676437	

OPERATING MANUAL



Pump side



Hose colors	
Gray	Product hose
Blue	Air hose

Gun side

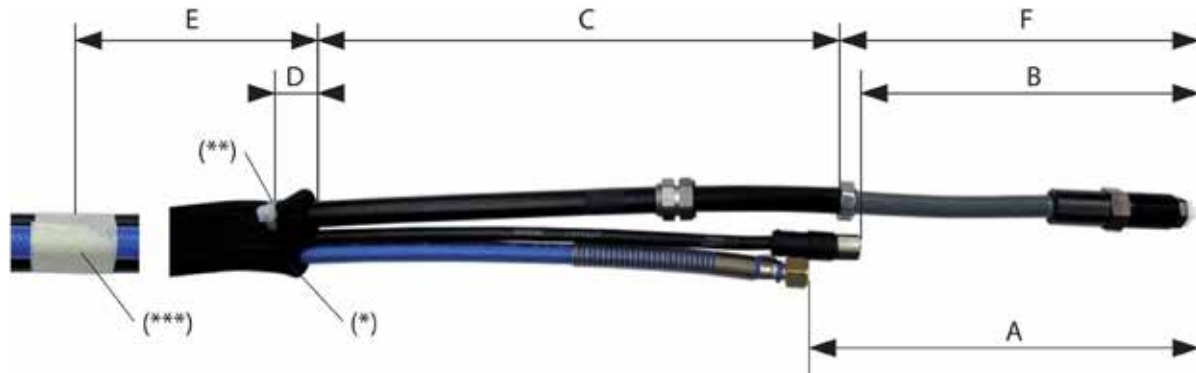

(*) Heat and fuse protective hose ends and bend inwards by approximately 5 cm; 2 inches.

(**) Fix the protective hose with cable ties on both sides **only once at the product hose**.

(***) Fix the hose set within the protective hose approx. once per meter by means of adhesive tape, starting at distance "E".

Note: Cable ties are not permitted in areas "C" and "E", except ().**







	A *	B *	C	D	E	F *
mm	200 +/- 2	171 +/- 2	300 +/-10	20 +/-10	1500 +100	182 +/- 1
inch	7.87 +/- 0.08	6.73 +/- 0.08	11.8 +/- 0.4	0.8 +/- 0.4	59 + 4	7.17 +/- 0.04



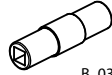
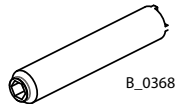
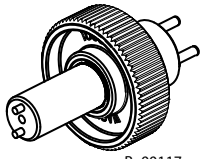
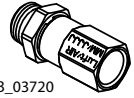
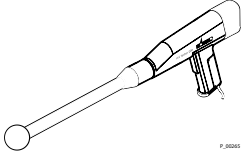

* Use an assembly gauge for distances A, B and F!

13.5 PRODUCT PRESSURE REGULATOR FOR DD10

Order No.	Designation	
2389505	Product pressure regulator for DD10 AquaCoat	<p>B_06781</p>

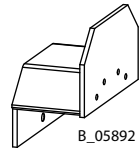
13.6 MISCELLANEOUS

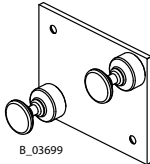
Order No.	Designation	
353702	High-voltage oil (10 ml; 10 cc) (for product hose → assembly)	
2319653	Protective gun coating	 B_03693
2309368	Valve needle assembly tool	 B_03451
2325263	Clamping screw assembly tool	 B_03681
353210	Air nozzle spanner For adjustable EAWRV 5000 round jet nozzle.	 B_00117
2324766	Swivel joint air	 B_03720
259010	High-voltage tester, HV 200 N	 P_0005
999080	Wet film thickness gauge	 B_03225
50342	Viscosity cup, DIN/4 (4 mm; 0.16 inches)	 B_03224
241270	Mains cable Europe (Schuko) 3 m; 9.8 ft	 B_01065
2330628	Mains cable Europe (Schuko) 10 m; 32.8 ft	
241271	Mains cable Switzerland 3 m; 9.8 ft	
264626	Mains cable USA 2 m; 6.6 ft	
264625	Mains cable Japan 3 m; 9.8 ft	

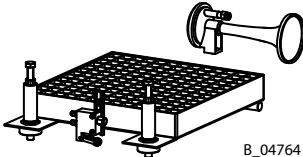
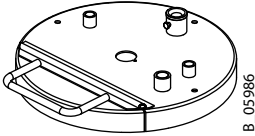
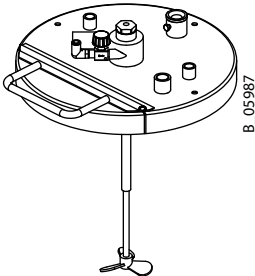
Order No.	Designation	
353050	Hose holder, complete	 B_05892
2359097	Gun holder. For assembly on hose holder 353050.	 B_05893
2326485	Wall mount, GM 5000E (left/right)	 B_03699
2359029	Underframe, 5020 with rolls	 B_05894
2364394	Underframe, 5010 with rolls	
2364791	Tub insert, 5020	 B_05895
2364790	Tub insert, 5010	
353053	Level monitoring, incl. alarm horn	 B_04764
353054	Drum cover, D350 without agitator	 B_05986
353055	Drum cover, D350 with agitator	 B_05987

14 SPARE PARTS

DANGER

Incorrect maintenance/repair!

Danger to life and equipment damage.

- Only a WAGNER service center or a suitably trained person may carry out repairs and replace parts.
- Only repair and replace parts that are listed in the "Spare parts" chapter and that are assigned to the unit.
- Before all work on the device and in the event of work interruptions:
 - Relieve the pressure from the device.
 - Secure the spray gun against actuation.
 - Switch off the energy and compressed air supply.
 - Disconnect the control unit from the mains.
- Observe the operating and service manual for all work.



14.1 HOW CAN SPARE PARTS BE ORDERED?

Always supply the following information to ensure delivery of the right spare part:

Order number, designation and quantity

The quantity need not be the same as the number given in the quantity column "**Stk**" on the list. This number merely indicates how many of the respective parts are used in each component.

The following information is also required to ensure smooth processing of your order:

- Address for the invoice
- Address for delivery
- Name of the person to be contacted in the event of any queries
- Type of delivery (normal mail, express delivery, air freight, courier etc.)

Identification in spare parts lists

Explanation of column "**K**" (labeling) in the following spare parts lists:

- ◆ Wearing parts Wearing parts are not included in the warranty terms.
- ★ Included in service set
- Not part of standard equipment, available, however, as additional extra.

Explanation of Order No. column:

- Item not available as spare part.
- / Item does not exist.

14.2 AQUACOAT BASIC DEVICE

AquaCoat basic sets: see Chapter [5.4.1](#)

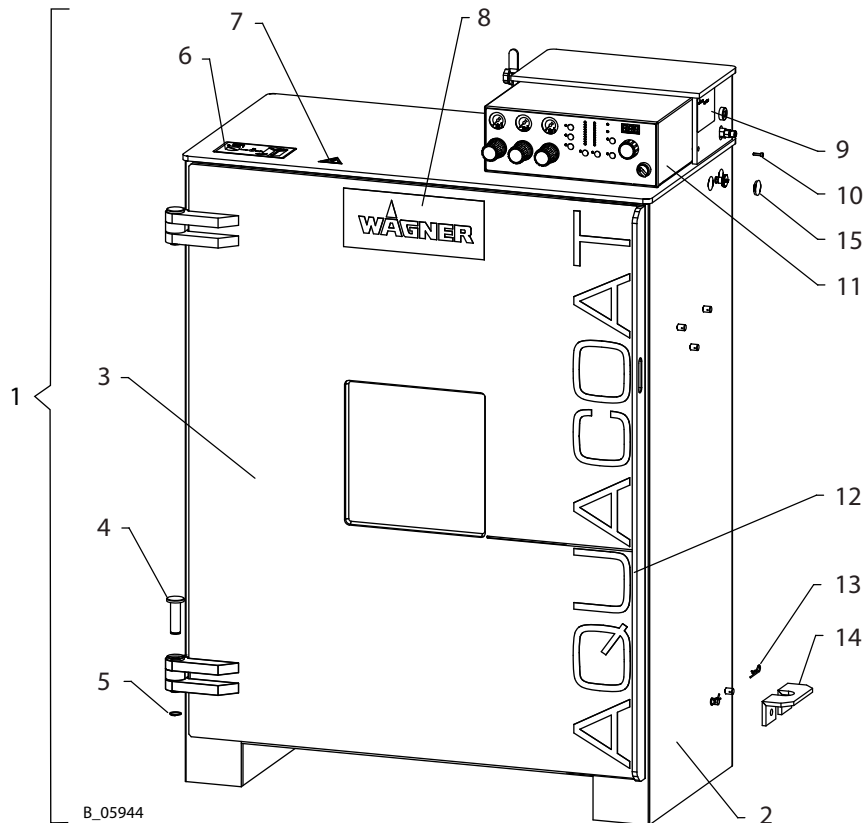

Spare parts list for AquaCoat basic device				5020	5020G	5010	5010G
Pos	K	Stk	Designation	Order No.	Order No.	Order No.	Order No.
1		1	Manual basic device, AquaCoat	2363292	2363734	2363401	2363736
2		1	AquaCoat cabinet	--		--	
3		1	Cabinet door, AquaCoat including items 8, 12, 95-98	2367567	2367570	2367569	2367571
4		2	Hinge bolt	2358921			
5		2	Securing ring	9922511			
6		1	Instruction label, AquaCoat 5020	2359298			
7		1	High-voltage warning sign, 50 mm	9952558			
8		1	Label, WAGNER	--			
9		1	Type plate, AquaCoat	--			
10		2	Hexagon socket cylinder head screw	9900308			
11		1	Control unit, VM 5020W For details, see Chapter 14.2.1	2362954			
12		1	Label, AquaCoat	--			
13		2	Connection fields	9935049			
14		1	Hose holder, below	2358373			
15		1	Plug	R204.07			

◆ = Wearing parts

Spare parts list for AquaCoat basic device				5020	5020G	5010	5010G
Pos	K	Stk	Designation	Order No.	Order No.	Order No.	Order No.
21		2	Hexagon socket cylinder head screw			9900365	
22		1	Pump support			2362723	
23		2	Hexagon socket cylinder head screw			9900346	
24		13	Washer			9920103	
25		7	Lock washer internal teeth			9922109	
26		1	Grounding cable, 10 m			130215	
27		1	Strain relief grommet, DM4			9999438	
28		1	Mains cable (see Chapter 13.4)			--	
29	◆	1	Ball valve			9991523	
30		2	Strain relief grommet, DM7			9999437	
31		1	Fitting, G1/2-G1/2A			9999440	
32		1	Straight hermetic plug connection, G inside			9992741	
33		1	Double fitting, G1/4-G1/4			9994627	
34		1	Interlock lever			2358914	
35		2	Grub screw			9901108	
36		1	Spring rod			2366942	
37	◆	1	Tension spring			2362850	
38		1	Driving pins			2358916	
39		1	Pushrod, welded			2358913	
41		1	Screw connector T			9999109	
42		2	Reducing fitting, A-G1/2-I-G1/4			9985685	
43		1	Male stud elbow, 10-1/4			9999208	
44		1	Threaded plug, G1/4"			9998274	
51		1	Hexagon socket cylinder head screw			9907050	
52		1	Washer			9920118	
53		6	Hexagon nut			9910102	
54		1	High knurled nut			9910522	
61		2	Hexagon nut			9910125	
62		2	Socket cap screw with slit			2311709	
63		1	Door switch, complete			2363036	
64		2	Hexagon nut			9910107	
65		3	Washer			9920102	
66		1	Hexagon socket cylinder head screw			9907079	
68		1	Washer			9920110	
120		1	Loctite® 542			9992831	
121		1	Loctite® 243			9992511	
122		1	Loctite® 270			9992528	

◆ = Wearing parts

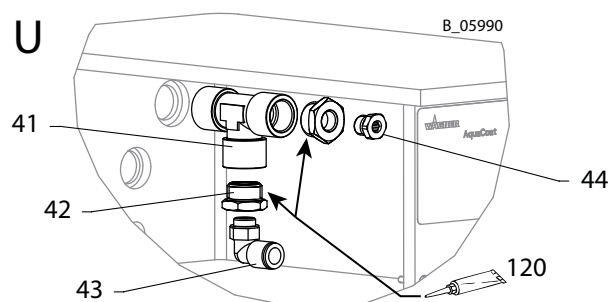

OPERATING MANUAL

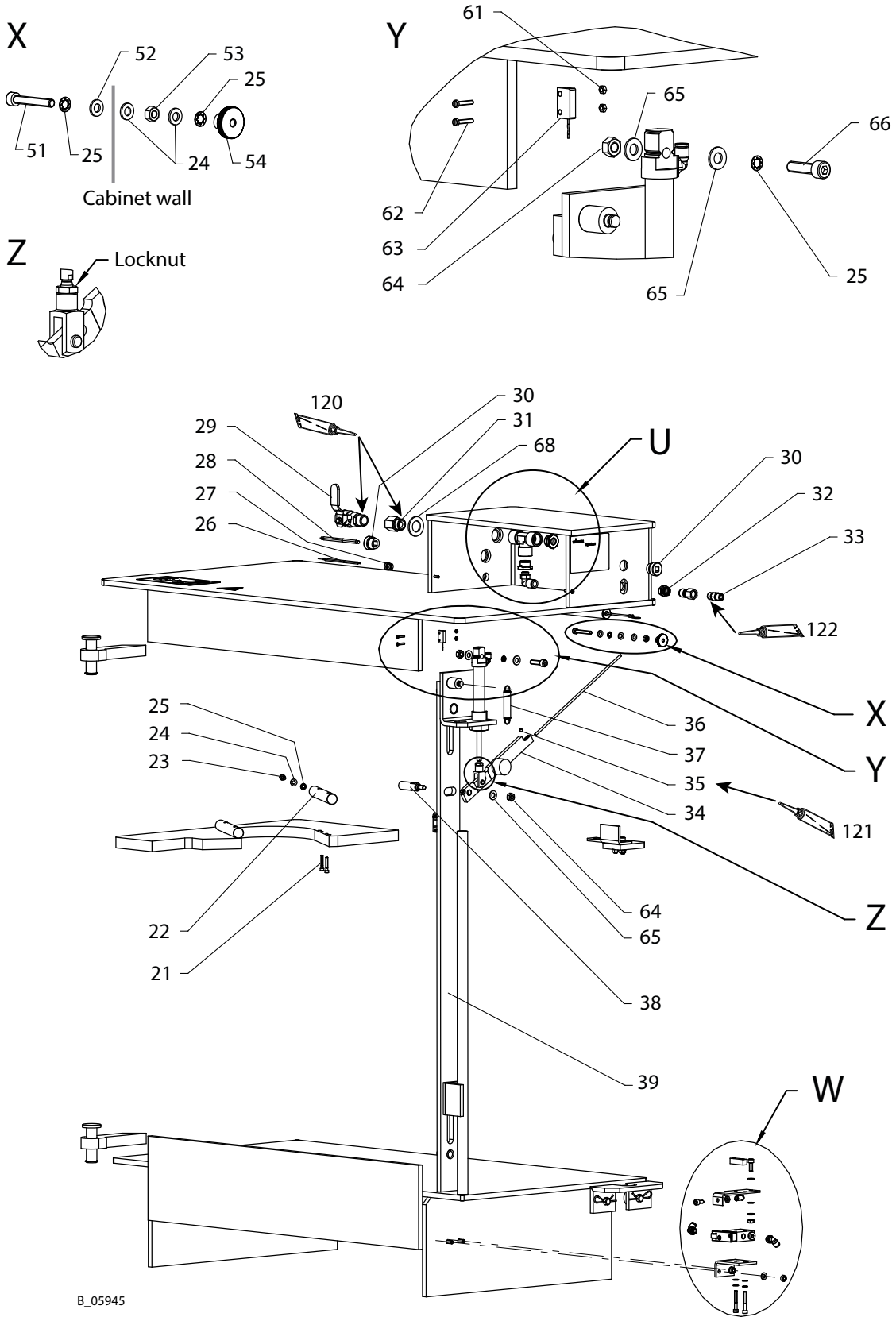

OPERATING MANUAL

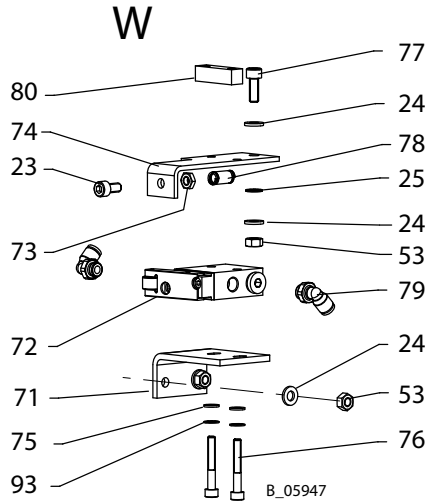

Locking device for cabinet door
(View from top)

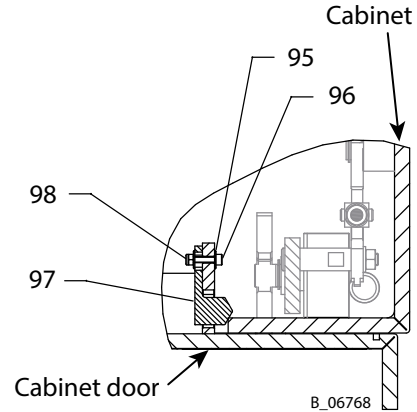

Spare parts list for AquaCoat basic device				5020	5020G	5010	5010G
Pos	K	Stk	Designation	Order No.	Order No.	Order No.	Order No.
71		1	Valve holder			2362721	
72		1	Roller lever valve, RS-3-1/8			2362775	
73		1	Hexagon nut, 0.5 d			9911005	
74		1	Grounding plate			2362722	
75		2	Washer			9920101	
76		2	Hexagon socket cylinder head screw			9907001	
77		1	Hexagon socket cylinder head screw			9900325	
78	◆	1	Pressure spring, 1.0x8.0 L=17			123357	
79		3	Male stud elbow 6-1/8, Ex			9998110	
80		1	Threaded anchor plate			2373026	
81		1	Shorting member			2358920	
82	◆	1	Standard cylinder, ESNU-20-50-P-A			2359249	
83		1	Hexagon screw without shaft			9907222	
84		1	AquaCoat resistor, 3 GOhm			353864	
85		1	Roll snapper			2362973	
86		2	Washer			9920114	
87		2	Screws, PT fillister head			9905504	
88		1	Rod clevis, SG-M8			2359255	
89		2	Washer			2358919	
90		3	Securing ring			9998144	
91		4	Hexagon socket cylinder head screw			9900315	
93		2	Lock washer internal teeth			9922106	
95		4	Washer			9920308	
96		2	Hexagon socket cylinder head screw			9906004	
97		2	Spring element			2373035	
98		2	Self-locking hexagon nut			9910202	

◆ = Wearing parts

OPERATING MANUAL

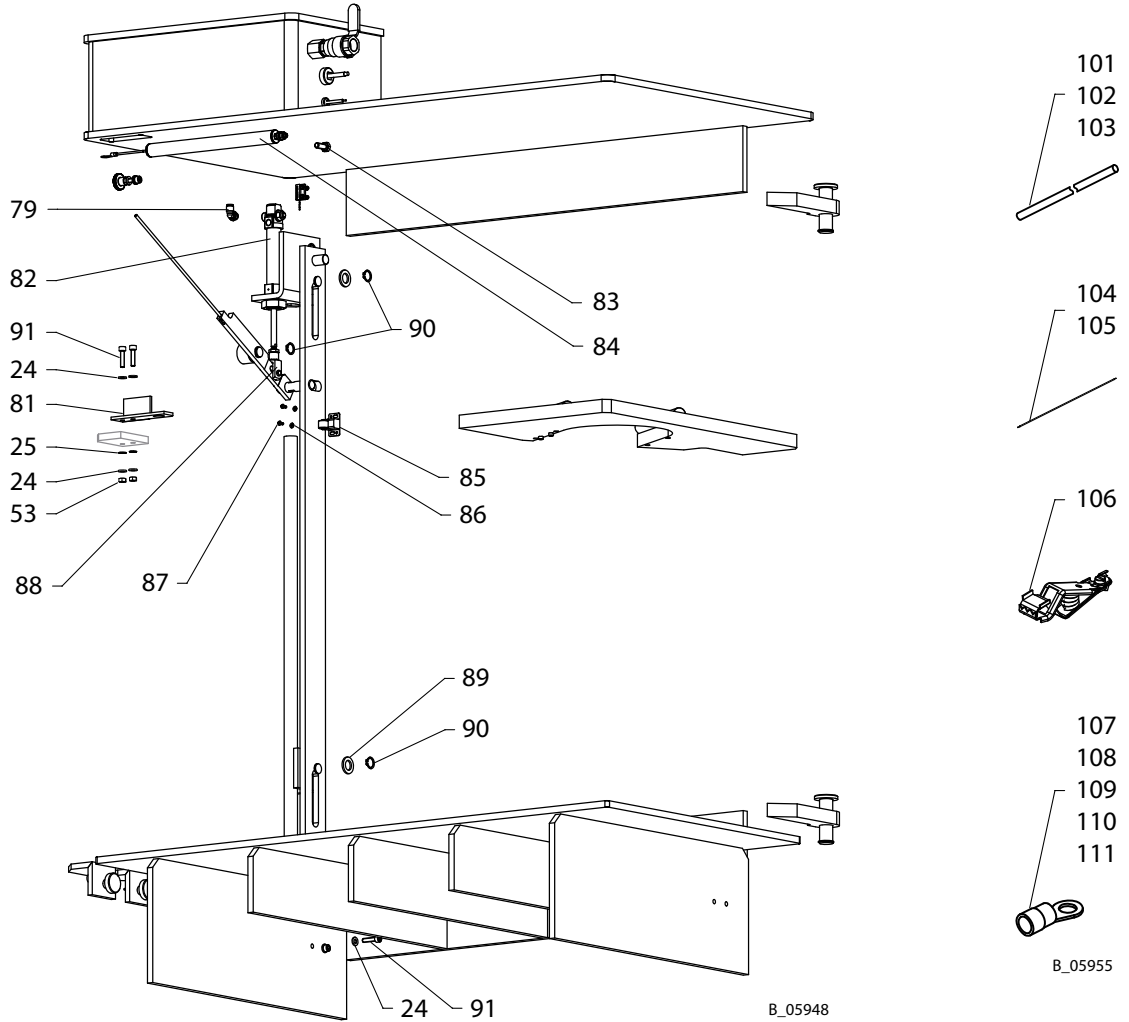

B_05955

B_05948

Spare parts list for AquaCoat basic device				5020	5020G	5010	5010G
Pos	K	Stk	Designation	Order No.	Order No.	Order No.	Order No.
101		2 m	Hose, black Ø 10 mm; 0.39 inches			9987076	
102		1.9 m	Hose, black Ø 8 mm; 0.32 inches			9982078	
103		3.7 m	Hose, black Ø 6 mm; 0.24 inches			9982079	
104		3.4 m	Strand, yellow/green			9953082	
105		4.2 m	Strand, orange			9953415	
106		1	Battery clip			9950585	
107		1	Cable lug, 0.5–1.0 mm ² M4			9950606	
108		1	Cable lug, 0.5–1.0 mm ² M5			9950656	
109		8	Cable lug, 0.5–1.0 mm ² M6			9950616	
110		5	Cable lug, 1.5–2.5 mm ² M6			9955403	
111		1	Cable lug, 1.5–2.5 mm ² M8			9950646	
120		1	Loctite® 542			9992831	
121		1	Loctite® 243			9992511	
122		1	Loctite® 270			9992528	

◆ = Wearing parts

14.2.1 VM 5020W CONTROL UNIT

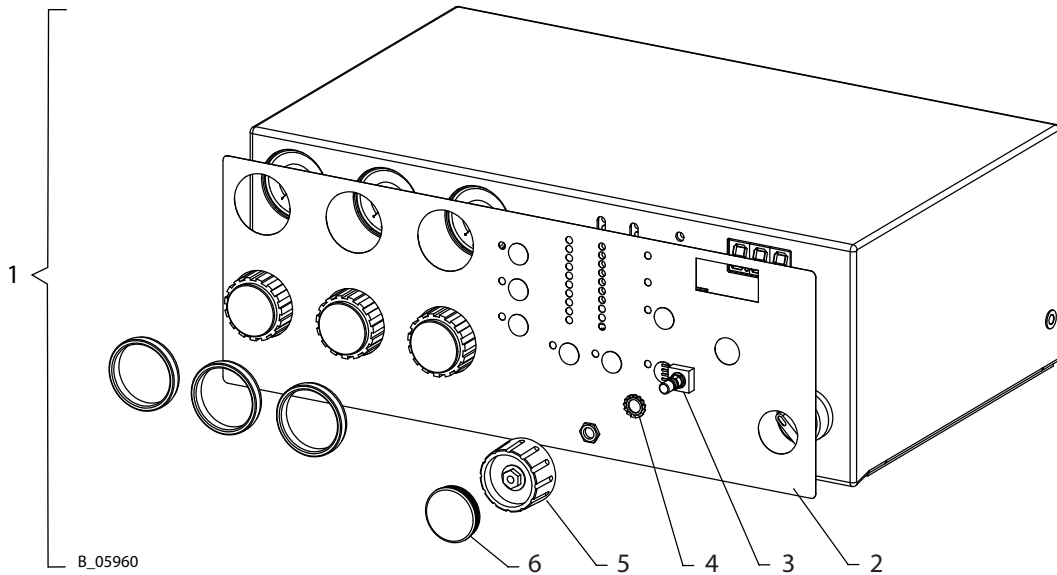

Spare parts list for VM 5020W control unit

Pos	K	Stk	Order No.	Designation
1		1	2362954	Control unit, VM 5020W
2		1	--	Front panel, VM 5000W
3		1	2304459	Incremental encoder, type E33
4		1	2329441	Serrated lock washer, externally toothed
5		1	2304461	Rotary knob
6		1	2304462	Cover

◆ = Wearing parts

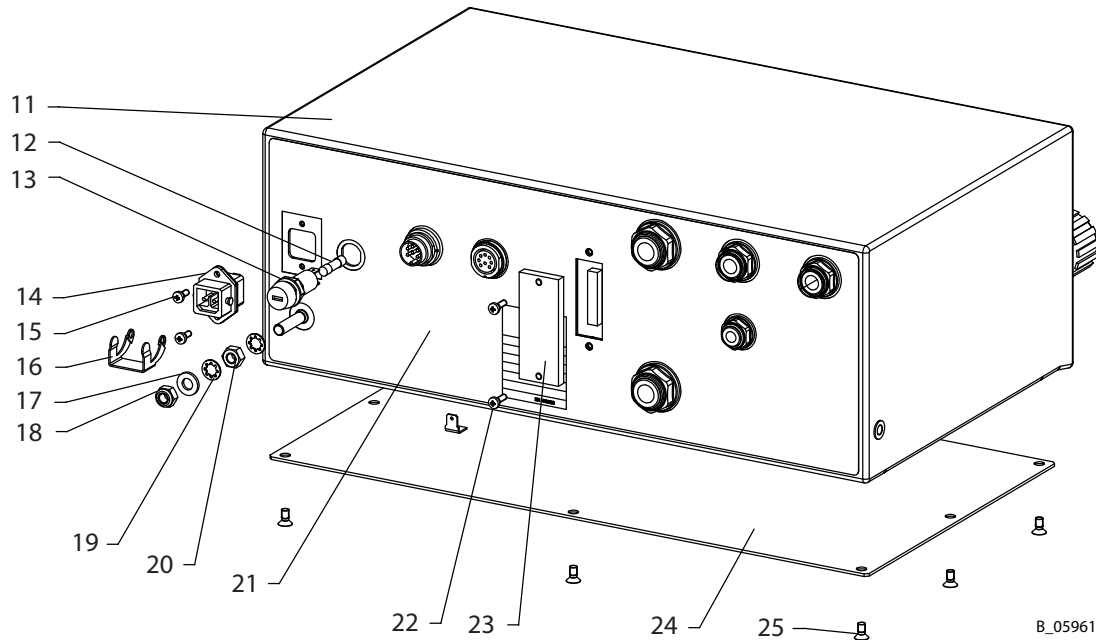

B_05961

Spare parts list for VM 5020W control unit

Pos	K	Stk	Order No.	Designation
11		1	--	Housing, VM 5020W
12		1	9951117	Delay-action fuse 1.0 AT
13		1	2348276	Fuse socket, FPG1 for 5x20 mm glass
14		1	--	Cable loom, VM 5020W
15		2	9903306	Recessed head raised fillister head screw, H form
16		1	9950330	Safety clip for device sockets
17		1	9920118	Washer
18		1	9910204	Self-locking hexagon nut
19		2	9922109	Lock washer internal teeth
20		1	9910102	Hexagon nut
21		1	--	Back sheet, VM 5020W
22		2	9903311	Recessed head raised fillister head screw, H form
23		1	241323	Cover, white
24		1	2353727	Cover
25		8	2306405	Recessed countersunk flat head screw, Z form

◆ = Wearing parts

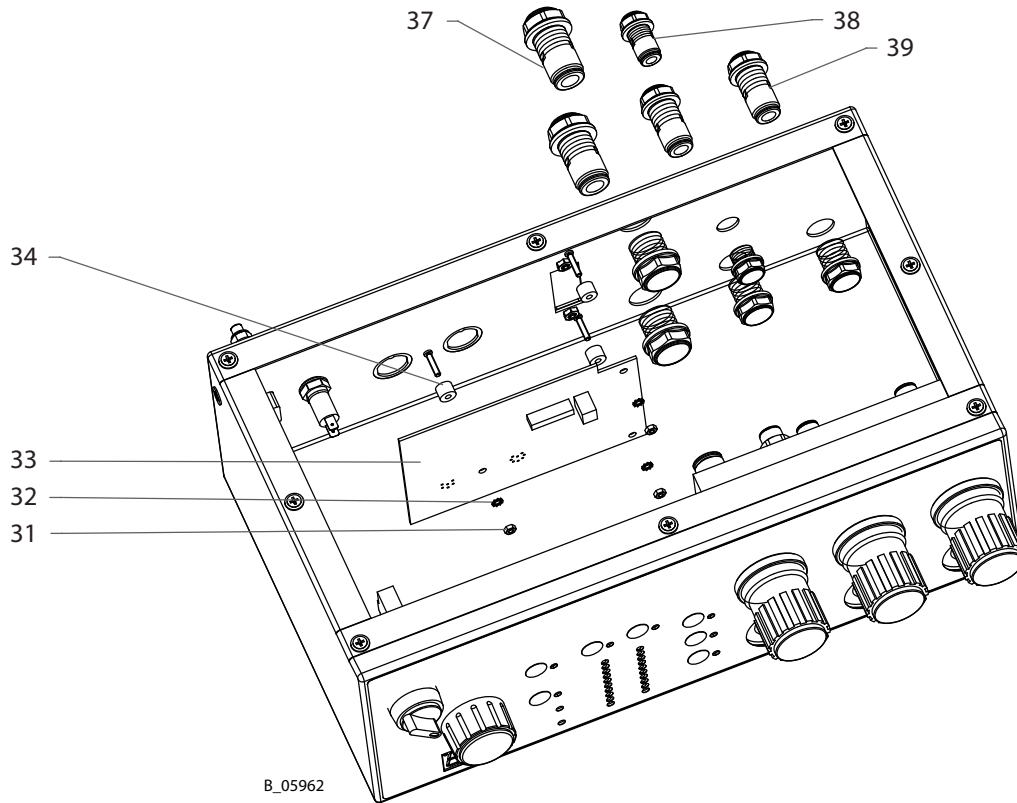

Spare parts list for VM 5020W control unit

Pos	K	Stk	Order No.	Designation
31		3	9910103	Hexagon nut
32		7	9922011	Serrated lock washer, externally toothed
33		1	2365967	Print VM 5020W rear panel, complete Including connector plug and socket
34		3	263400	Distance bush
37		2	9998769	Straight hermetic plug connection, D=10
38		1	9998614	Straight hermetic plug connection, D = 6
39		2	9998615	Straight hermetic plug connection, D = 8

◆ = Wearing parts

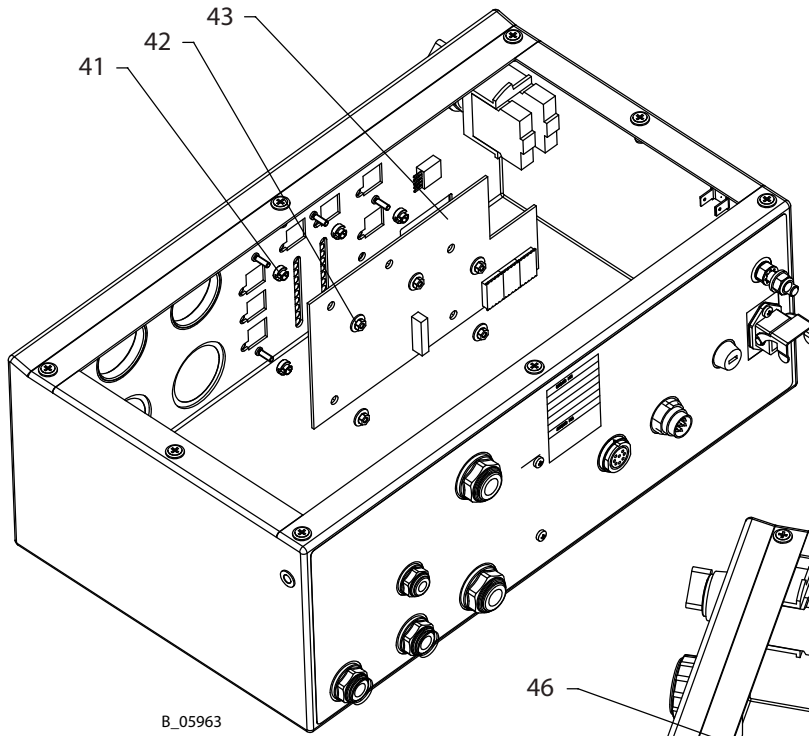

B_05963

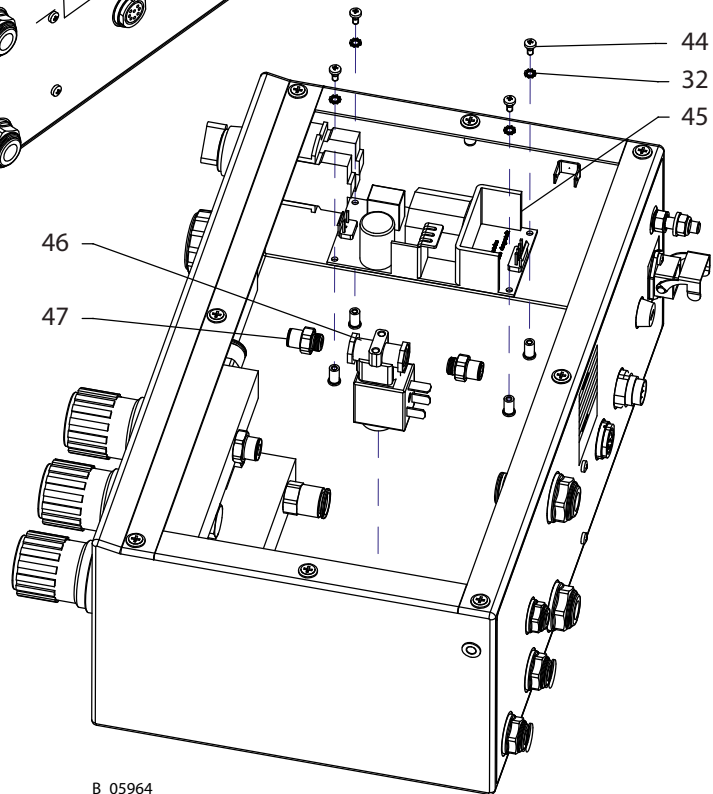

B_05964

Spare parts list for VM 5020W control unit

Pos	K	Stk	Order No.	Designation
41		5	2309112	Spacer
42		5	2312348	Hexagon lock nut
43		1	2317539	Print, complete for VM 5000 display. Including Pos 3.
44		4	9903312	Recessed head raised fillister head screw, H form
45		1	2352818	Switching power supply, EPS-45-24
46		1	2360090	Solenoid valve, complete
47		2	9998090	Straight screw-in fitting

◆ = Wearing parts

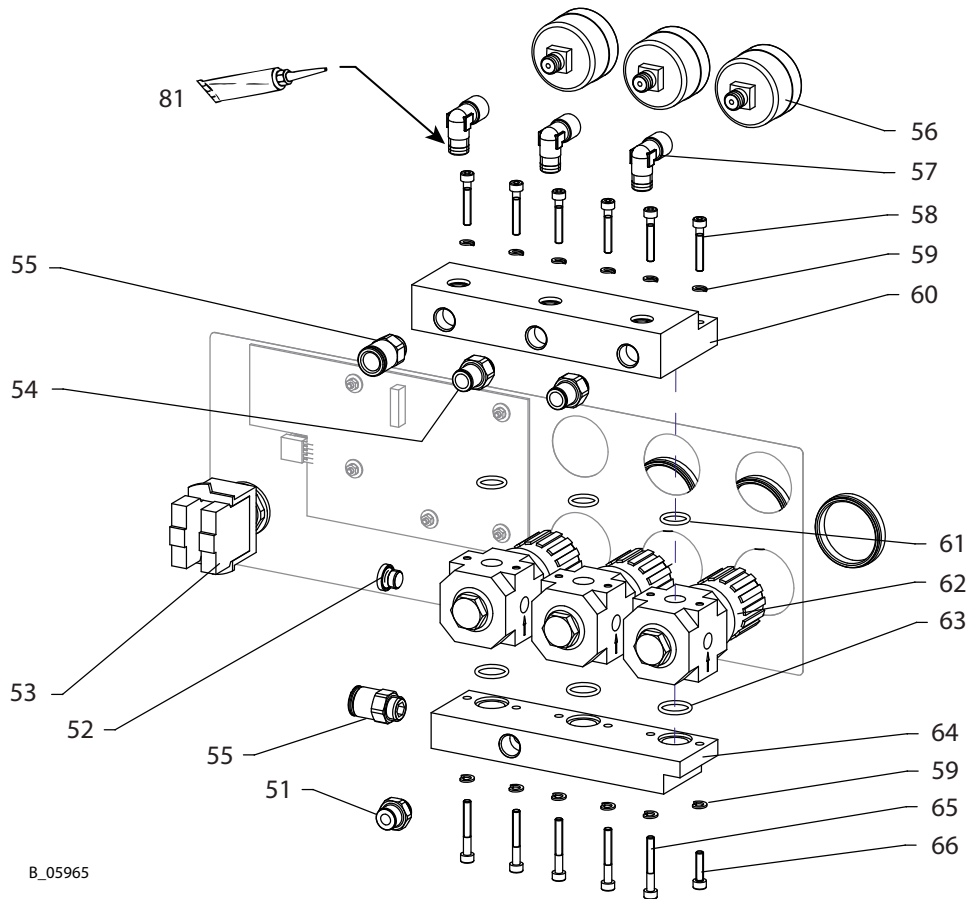

B_05965

Spare parts list for VM 5020W control unit

Pos	K	Stk	Order No.	Designation
51		1	9998255	Straight threaded fitting
52		3	9998675	Threaded plug, G1/8"
53		1	9956178	Switch
54		2	9998254	Screw-in fitting, 8 mm - 1/4"
55		2	9998987	Threaded fitting, 10 mm - 1/4"
56	◆	3	9998677	Pressure gauge, 0-10 bar RF40 (d40)
57		3	9992289	Male stud elbow
58		6	9900365	Hexagon socket cylinder head screw
59		12	9921511	Spring washer
60		1	2335187	Air outlet, 3-fold
61	◆	3	9971313	O-ring
62		3	2309972	Pressure regulator, LR-1/4-D-O-I-Mini
63	◆	3	9974166	O-ring
64		1	2335186	Air inlet, 3-fold
65		5	9900386	Hexagon socket cylinder head screw
66		1	9900308	Hexagon socket cylinder head screw

Mounting materials

81		1	9992831	Loctite® 542
----	--	---	---------	--------------

◆ = Wearing parts

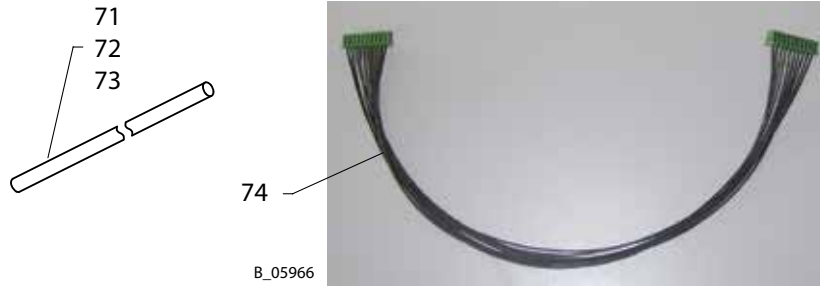

Spare parts list for VM 5020W control unit

Pos	K	Stk	Order No.	Designation
71		0.45 m	9987076	Hose, black Ø 10 mm; 0.39 inches
72		0.30 m	9982078	Hose, black Ø 8 mm; 0.32 inches
73		0.16 m	9982079	Hose, black Ø 6 mm; 0.24 inches
74		1	2304487	Print connection cable

◆ =Wearing parts

14.3 PUMP SETS

14.3.1 DD10 SET

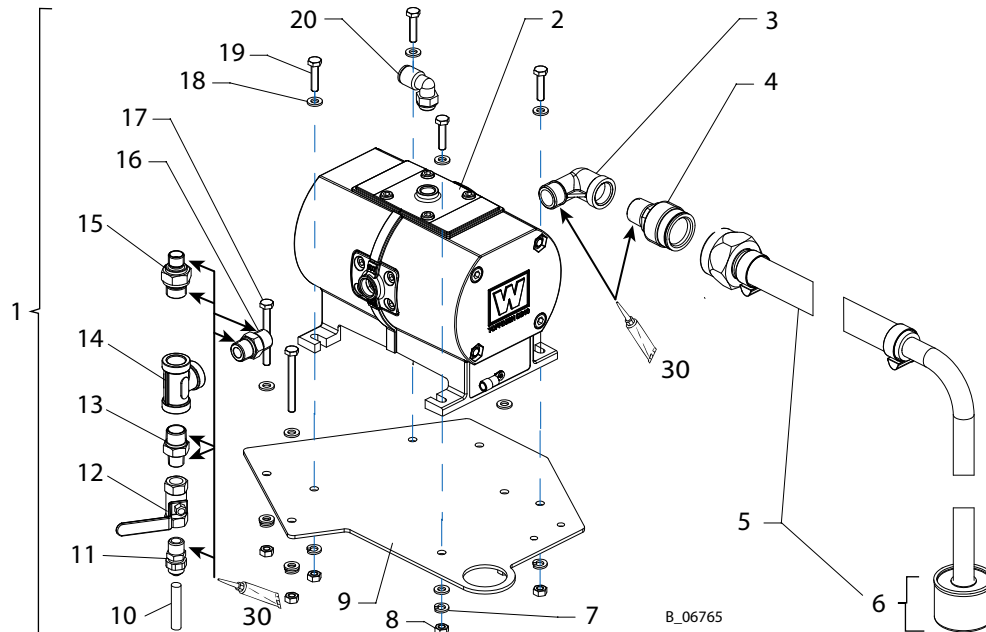

DD10 set spare parts list for AquaCoat

Pos	K	Stk	Order No.	Designation
1		1	2364024	DD10 set for AquaCoat
2		1	2368651	Double diaphragm pump, TOPFINISH DD10 Refer to pump's operating manual for details
3		1	2315783	Fitting, EF-MF-R1/2"-G1/2"-SSt
4		1	2329560	Fitting, DF-MM-R1/2"-M36-PN15-SSt
5	◆	1	2324110	Suction hose, complete DN16-SSt
6	◆	1	2323396	Suction filter, DN16-18mesh-SSt
7		8	9921502	Spring washer
8		8	9910102	Hexagon nut
9		1	2372633	Mounting plate
10	◆	0.1 m	S103.07N	Hose, PA12 D8 anti-static
11		1	M057.07	Fitting, 1/4"x8"
12	◆	1	M513.00IA	Ball valve, 1/4" SS
13		1	2328291	Fitting, DF-MM-R3/8-R1/4-530 bar-SSt
14		1	9985789	T-piece
15		1	2325826	Fitting, DF-MM-G3/8-G1/4-530 bar-SSt
16		1	2368425	Fitting, DF-MM-R3/8-R3/8-530 bar-SSt
17		4	3061695	Hexagon screw without shaft
18		16	9920103	Washer
19		4	9900224	Hexagon screw without shaft
20		1	9999208	Male stud elbow, 10-1/4
30		1	9992831	Loctite® 542 - 50 ml

◆ = Wearing parts



14.3.2DD10 SET WITH PRODUCT PRESSURE REGULATOR

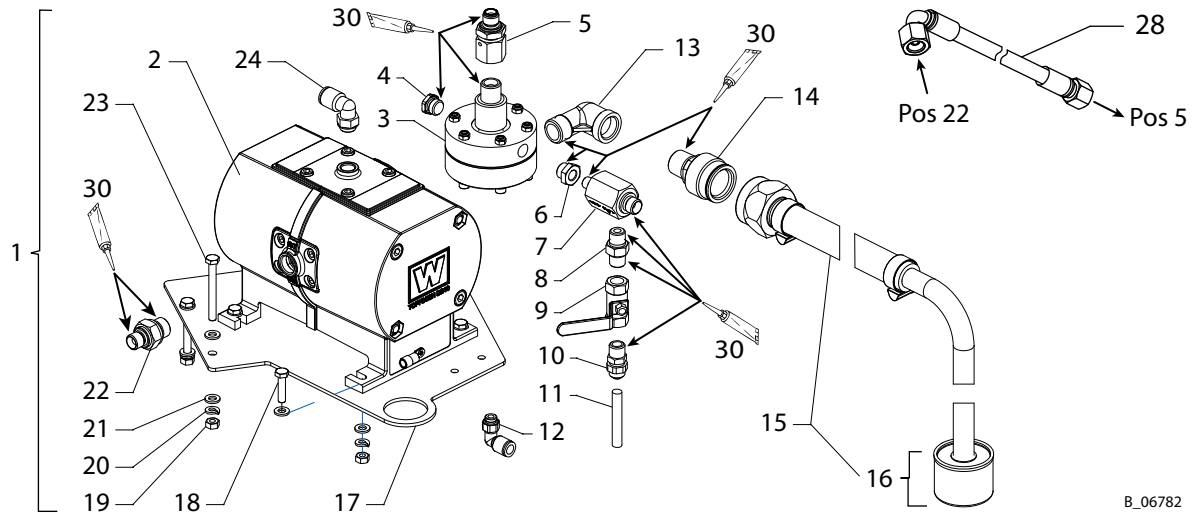

B_06782

DD10 set spare parts list for AquaCoat with product pressure regulator

Pos	K	Stk	Order No.	Designation
1		1	2390123	DD10 set for AquaCoat with product pressure regulator
2		1	2368651	Double diaphragm pump, TOPFINISH DD10 Refer to pump's operating manual for details
3		1	T0170.00BI	MPR 40/0.5-8 bar pneumatic SSSt Refer to product pressure regulator's operating manual for details
4		1	9998274	Threaded plug, G1/4"
5		1	2331971	Fitting, SF-FM-G3/8-G1/4-530 bar-SSSt
6		1	9985559	Reducing fitting
7		1	2372632	Fitting, DF-MM-R1/8-G1/4-350 bar
8		1	2325839	Fitting, DF-MM-R1/4-R1/4-530 bar-SSSt
9	◆	1	M513.00IA	Ball valve, 1/4" SS
10		1	M057.07	Fitting, 1/4"x8"
11	◆	0.1 m	S103.07	Hose
12		1	9992757	Male stud elbow, 8-1/8
13		1	2315783	Fitting, EF-MF-R1/2-G1/2-SSSt
5		1	2329560	Fitting, DF-MM-R1/2"-M36-PN15-SSSt
15	◆	1	2324110	Suction hose, complete DN16-SSSt
16	◆	1	2323396	Suction filter, DN16-18mesh-SSSt
17		1	2372633	Mounting plate
18		4	9900224	Hexagon screw without shaft
19		8	9910102	Hexagon nut
20		8	9921502	Spring washer
21		16	9920103	Washer
22		1	2325826	Fitting, DF-MM-G3/8-G1/4-530 bar-SSSt
23		4	3061695	Hexagon screw without shaft
24		1	9999208	Male stud elbow, 10-1/4
28	◆	1	2333833	HP hose, complete
30		1	9992831	Loctite® 542 - 50 ml

◆ = Wearing parts

14.3.3 ZIP52 SET

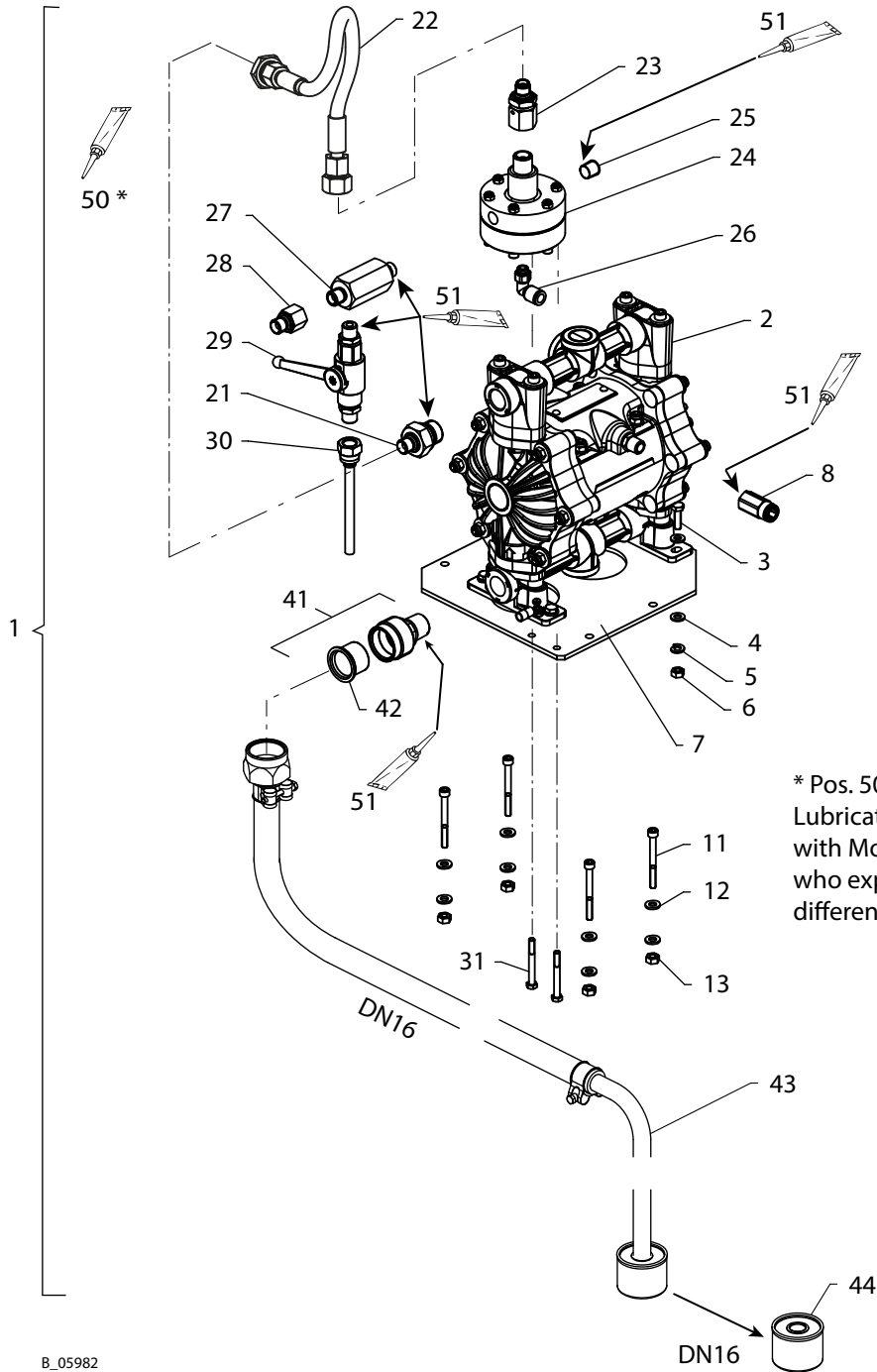

B_05982

OPERATING MANUAL



ZIP52 set spare parts list for AquaCoat

Pos	K	Stk	Order No.	Designation
1		1	2363856	ZIP52 set for AquaCoat

Double diaphragm pump

2		1	U552.GHSS7	DDP ZIP52 GHSS7 Refer to pump's operating manual for details
3		4	9900108	Hexagon screw without shaft
4		8	9920103	Washer
5		4	9921502	Spring washer
6		4	9910102	Hexagon nut
7		1	353530	Mounting plate
8		1	3304972	Connector female, 6463-10-1/4

Mount on pump support

11		4	3061695	Hexagon screw without shaft
12		8	9920103	Washer
13		4	9910204	Self-locking hexagon nut

Product outlet

21		1	2331062	Fitting, DF-MM-G1/2-G1/4-530 bar-SSt
22	◆	1	2333833	HP hose, complete
23		1	2331971	Fitting, SF-FM-G3/8-G1/4-530 bar-SSt
24		1	T0170.00BI	MPR 40/0.5-8 bar pneumatic SSt Refer to product pressure regulator's operating manual for details
25		1	9907019	Screw plug
26		1	9992757	Male stud elbow, 8-1/8
27		1	B0461.03A	Fitting, DF-MM-R1/4-1/4NPSM-350 bar-SSt
28		1	2364712	Fitting, RF-FM-NPS1/4-G1/4-530 bar-SSt
29	◆	1	2334488	Ball valve R1/4"-G1/4"-PN530-SSt
30	◆	1	2331752	Return tube, DN6-G1/4"-100mm-PA
31		2	9907001	Hexagon socket cylinder head screw

Product inlet

41		1	2329560	Fitting, DF-MM-R1/2"-M36-PN15-SSt
42		1	2329898	Sealing sleeve
43	◆	1	2324110	Suction hose, complete DN16-SSt
44	◆	1	2323396	Suction filter, DN16-18mesh-SSt

Mounting materials

50		1	9992616	Molykote® DX grease
51		1	9992831	Loctite® 542

◆ = Wearing parts



14.4 GM 5020EAW SPRAY GUN

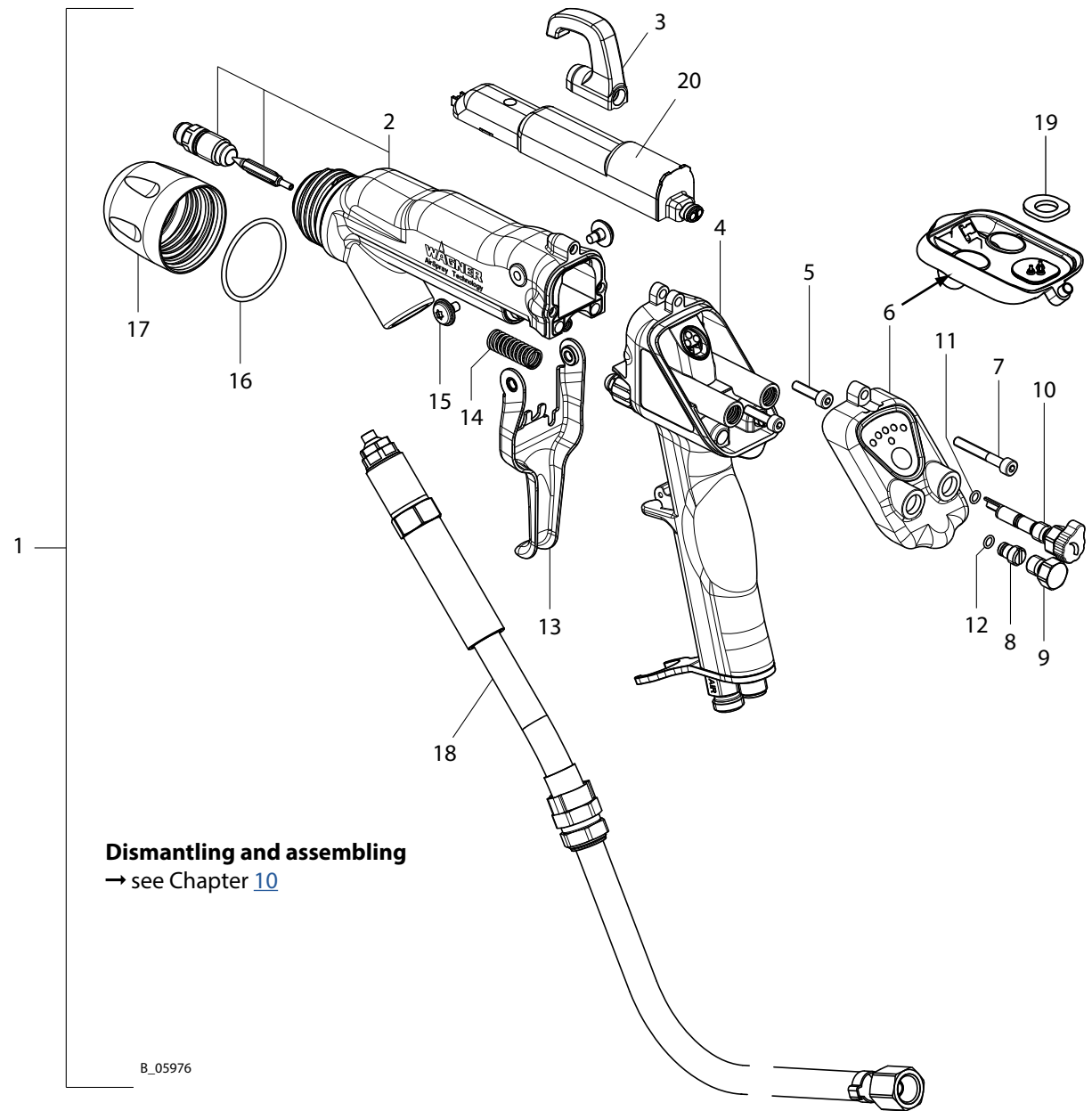

Spare parts list for GM 5020EAW spray gun

Pos	K	Stk	Order No.	Designation
1		1	2362852	GM 5020EAW
2		1	--	Adapter, complete GM 5000EA, for details, see Chapter 14.4.1
3		1	2314361	Hook
4		1	--	Handle, complete ES 5000 Air, for details, see Chapter 14.4.2
5		2	9900308	Hexagon socket cylinder head screw
6		1	2312183	Lid complete
7		1	9900386	Hexagon socket cylinder head screw
8		1	2311970	Sealing plug
9		1	2307104	Screw plug
10		1	2312180	Air regulation complete
11	◆ ★	1	9971182	O-ring
12	◆ ★	1	9971182	O-ring
13	◆	1	2314360	Trigger
14		1	2311849	Cylindrical helical spring
15		2	2310617	Oval head screw with hexalobular socket
16	◆ ★	1	2311217	O-ring
17		1	2307039	Union nut for flat jet and AWR 5000
	●	1	2361272	Union nut, EARV LV (see Chapter 14.5.2)
	●	1	2365978	Union nut, EARV HV (see Chapter 14.5.2)
18	◆ ●	1	2309907	Product hose, complete DN6 EAW, 7.5 m; 24.6 ft
			2309909	Product hose, complete DN6 EAW, 10 m; 32.81 ft
			2309910	Product hose, complete DN6 EAW, 15 m; 49.2 ft
			2309911	Product hose, complete DN6 EAW, 20 m; 65.6 ft
			2363037	Product hose, complete DN6 EAW, 7.5 m; 24.6 ft
			2363038	Product hose, complete DN6 EAW, 10 m; 32.81 ft
			2363039	Product hose, complete DN6 EAW, 15 m; 49.2 ft
2363040	Product hose, complete DN6 EAW, 20 m; 65.6 ft			
19	◆ ★	1	2308699	Cover seal
20		1	2312181	Cascade, complete GM 5000E
		1	2326391	Service set, GM 5000EAW / GM 5020EAW

◆ = Wearing parts

★ = Included in service set

● = Not part of the standard equipment but available as a special accessory.

14.4.1 GM 5000EA ADAPTER

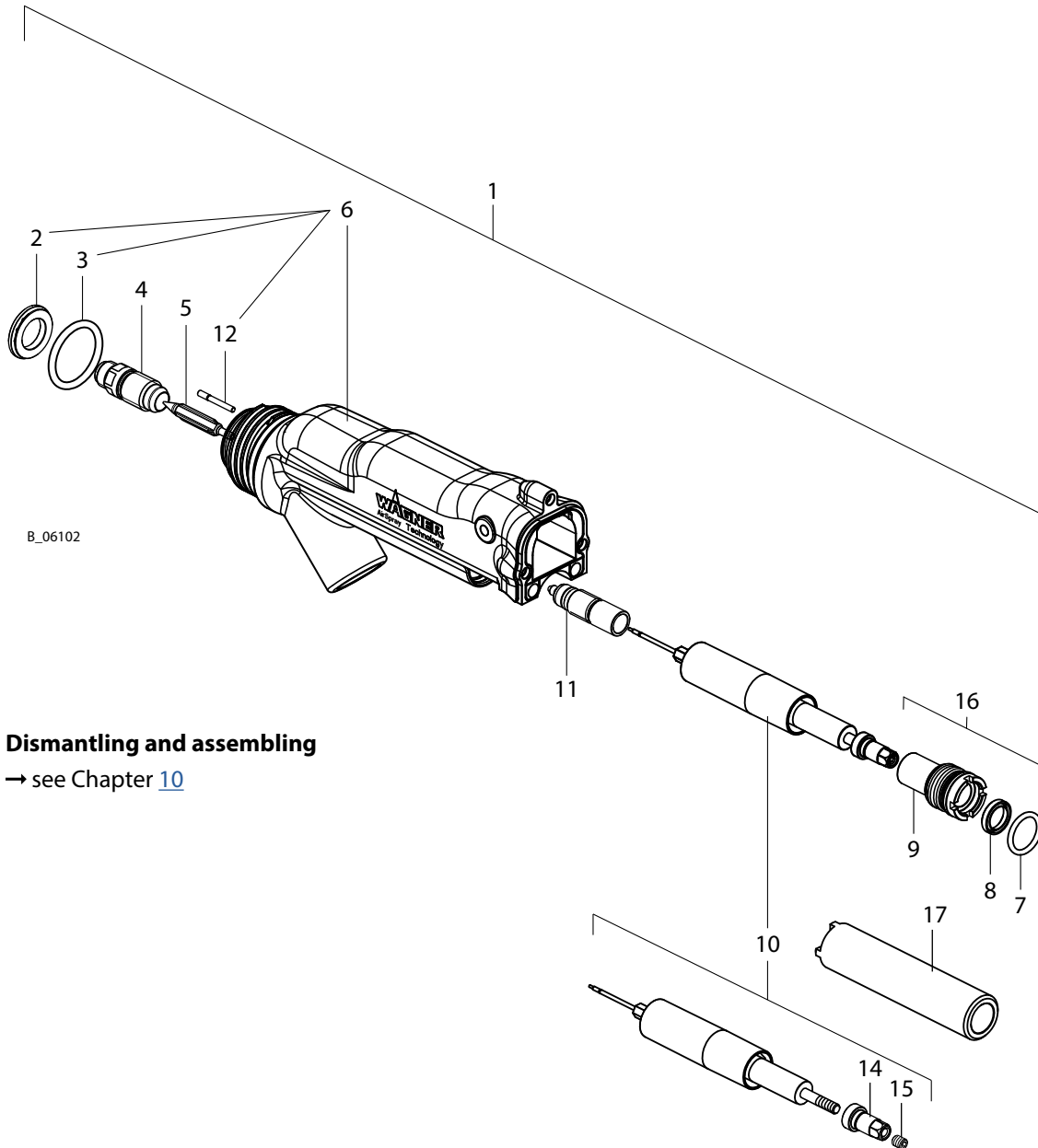

B_06102

Dismantling and assembling

→ see Chapter [10](#)

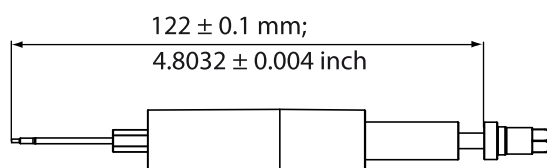

Spare parts list for GM 5000EA adapter

Pos	K	Stk	Order No.	Description
1		1	--	Adapter, complete GM 5000EA
2	★	1	2309391	Air manifold ring, Air
3	◆ ★	1	2307180	O-ring, sheathed
4	◆ ★ ●	1	2312176	Valve seat Air, complete (PEEK)
	◆ ★	1	2312179	Valve seat Air, complete (steel)
5	◆ ★	1	2312187	Valve tip EAW, complete (PEEK)
	◆ ●	1	2312188	Valve tip EAW, complete (steel)
6		1	2314271	Adapter, GM 5000EA, including pos. 2 and 3
7	◆ ★	1	9974166	O-ring
8	◆ ★	1	2311562	Rod seal
9		1	2307062	Clamping screw valve rod
10		1	2312177	Valve rod unit, Air
11	◆ ★	1	2357106	Packing, complete
12		1	2309346	Plug
14		1	2307059	Withdrawal nut
15		1	9901411	Threaded pin with hexagon socket
16		1	2357665	Clamping screw valve rod, complete
17		1	2325263	Clamping screw assembly tool
		1	2326391	Service set, GM 5000EAW / GM 5020EAW

◆ = Wearing parts

★ = Included in service set

● = Not part of the standard equipment but available as a special accessory.



14.4.2 ES 5000 AIR HANDLE

Dismantling and assembling

→ see Chapter 10

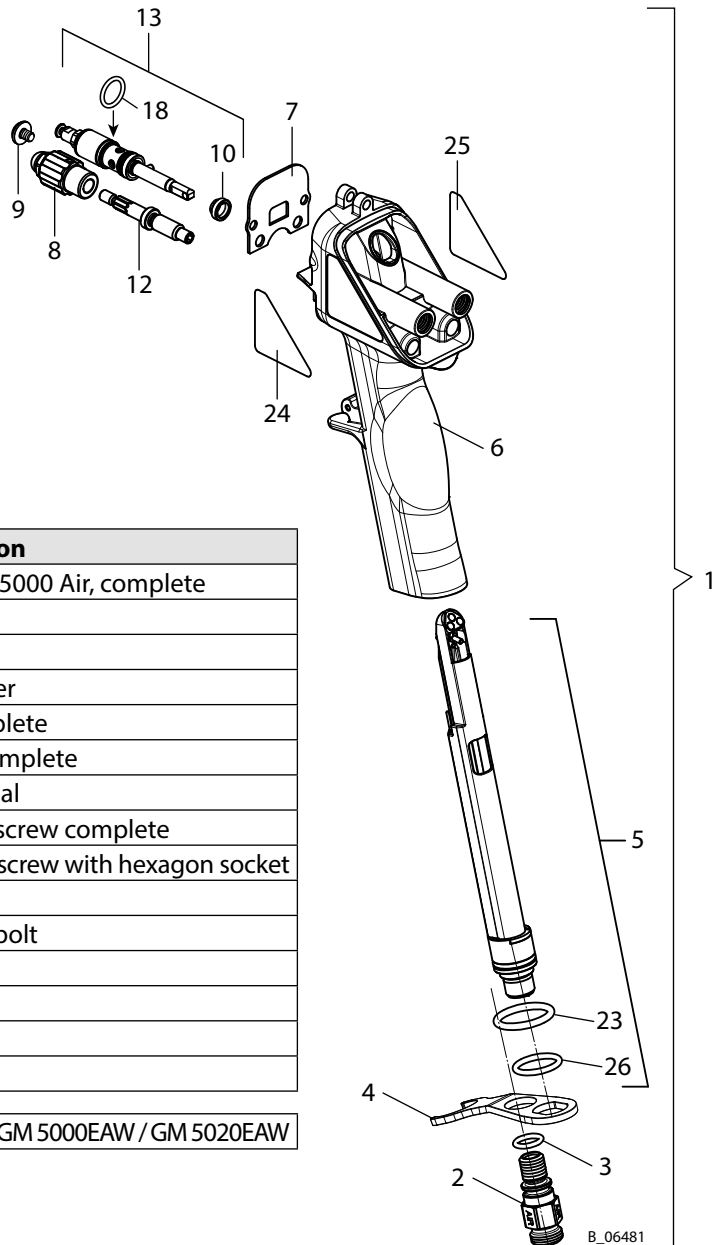

Spare parts list handle ES 5000 Air

Pos	K	Stk	Order No.	Designation
1		1	--	Handle ES 5000 Air, complete
2		1	2307288	Nipple
3	◆★	1	9971025	O-ring
4		1	2307290	Hose holder
5		1	2312182	Plug, complete
6		1	2314270	Handle, complete
7	★	1	2307232	Adapter seal
8		1	2325789	Adjusting screw complete
9		1	2309825	Oval head screw with hexagon socket
10	◆★	1	2310692	Seal
12		1	2307281	Threaded bolt
13		1	2312189	Air valve
18	◆★	1	9974218	O-ring
23	◆★	1	9974166	O-ring
26	◆	1	9971364	O-ring

		1	2326391	Service set, GM 5000EAW / GM 5020EAW
--	--	---	---------	--------------------------------------

◆ = Wearing parts

★ = Included in service set

14.5 ACCESSORIES SPARE PARTS LISTS

14.5.1 AWR 5000 ROUND JET NOZZLES

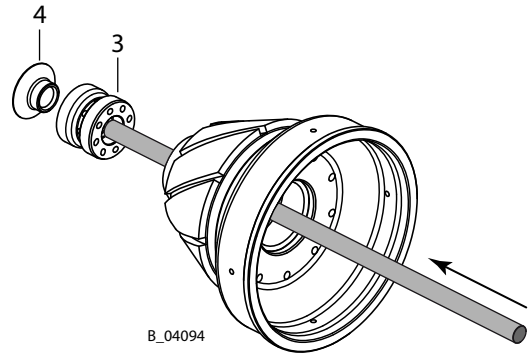
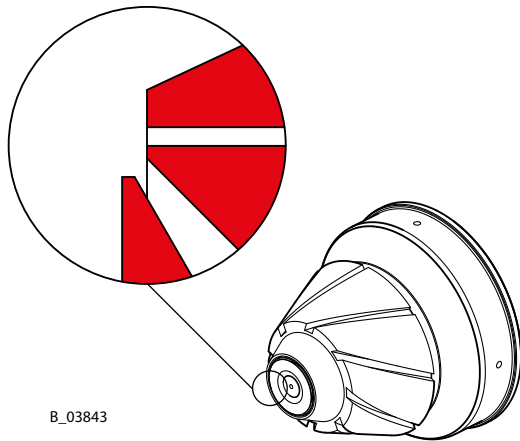

Note:
Parts 3 and 4 can be pushed out of the nozzle with a suitable pin (∅ 2.0–2.3 mm; 0.08–0.09 inch).

! NOTICE
Incorrect assembly!
 Damage to the parts or device.
 → Do not deteriorate the edges of the parts (see detail) during assembly (press parts carefully on stop).

14.5.1.1 AWR 5000 (D8) NOZZLE

AWR 5000 (D8) nozzle spare parts list

Pos	K	Stk	Order No.	Designation
1		1	2310559	Nozzle, complete AWR 5000 (D8)
2	◆	1	2327658	Nozzle, AR (D8)
3	◆	1	2327666	Nozzle attachment, AWR (D8)
4	◆	1	2327660	Air diffuser, AR (D8)

◆ = Wearing parts

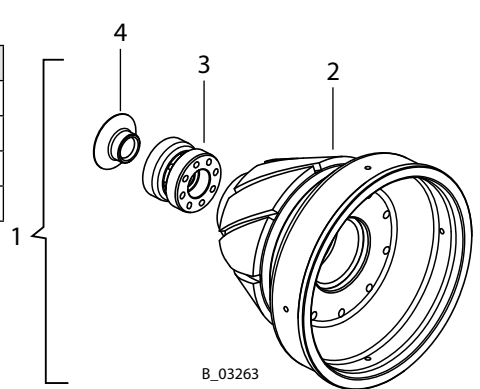



14.5.1.2 AWR 5000 (D12) NOZZLE

AWR 5000 (D12) nozzle spare parts list

Pos	K	Stk	Order No.	Designation
1		1	2315051	Nozzle, complete AWR 5000 (D12)
2	◆	1	2327661	Nozzle, AR (D12)
3	◆	1	2327667	Nozzle attachment, AWR (D12)
4	◆	1	2327663	Air diffuser, AR (D12)

◆ = Wearing parts

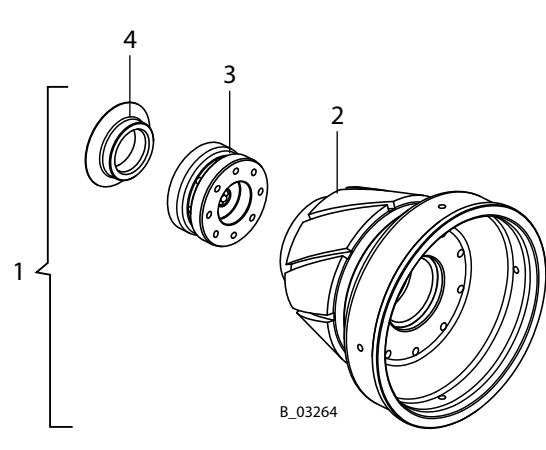

14.5.2 ADJUSTABLE EAWRV 5000 ROUND JET NOZZLES

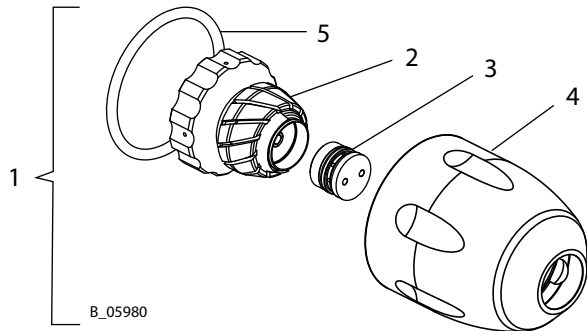

Markings on union nut

LV	HV
Low-viscosity (LV) products	High-viscosity (HV) products
B_05984	B_05985

EAWRV 5000 spare parts list				LV	HV
				Low-viscosity (LV) products	High-viscosity (HV) products
Pos	K	Stk	Designation	Order No.	Order No.
1		1	Nozzle set, EAWRV 5000	2366998	2366997
2	◆	1	Nozzle, EARV	2361273	
3	◆	1	Nozzle insert, EAWRV	2366986	
4		1	Union nut, EARV	2361272	2365978
5	◆ ★	1	O-ring, sheathed	2311217	

◆ = Wearing parts

★ = Included in GM 5020EAW service set. See Chapter 14.4.

Mounting tool		
353210	Air nozzle spanner	B_00117

14.5.3 UNDERFRAME WITH ROLLS

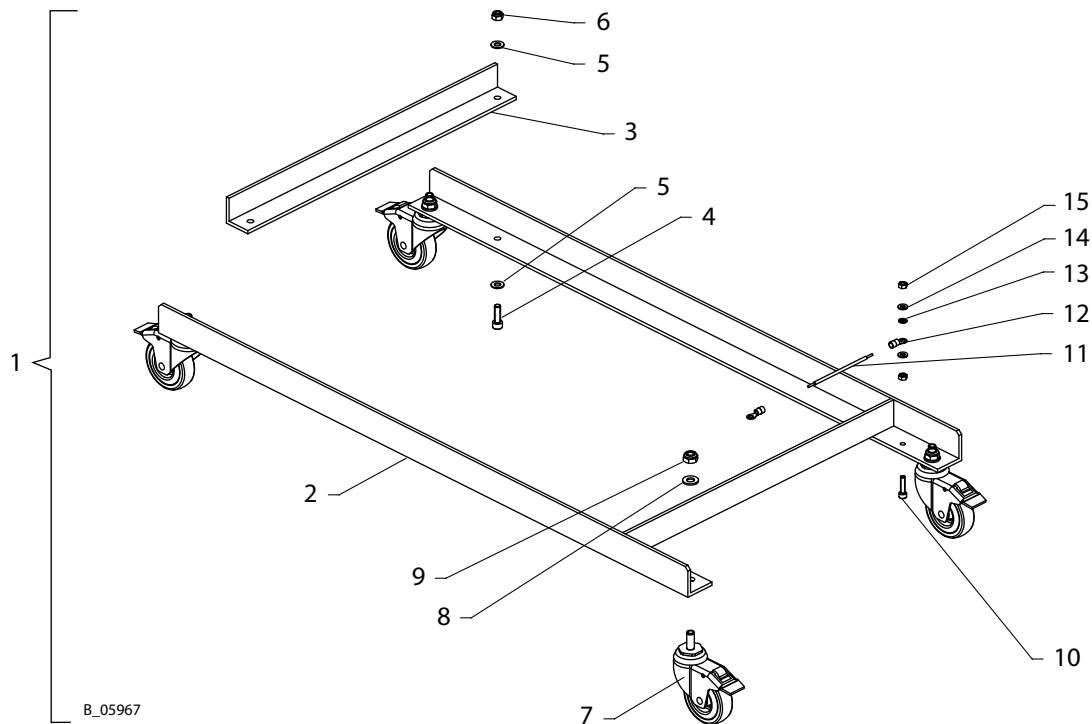

Spare parts list for underframe with rolls				5020	5020G	5010	5010G
Pos	K	Stk	Designation	Order No.	Order No.	Order No.	Order No.
1		1	Underframe with rolls	2359029		2364394	
2		2	Swivel castor support	--		--	
3		2	Crossbar		--		
4		4	Hexagon socket cylinder head screw		9900313		
5		8	Washer		9920102		
6		4	Self-locking hexagon nut		9910208		
7		4	Swivel castor with double stop		9994947		
8		4	Washer		9920106		
9		4	Hexagon nut with clamp		3055157		
10		1	Hexagon socket cylinder head screw		9900315		
11		0.6 m	Ground wire		9951211		
12		2	Cable lug		9950604		
13		1	Lock washer internal teeth		9922109		
14		2	Washer		9920118		
15		2	Hexagon nut		9910102		

◆ = Wearing parts

14.5.4 HOSE HOLDER

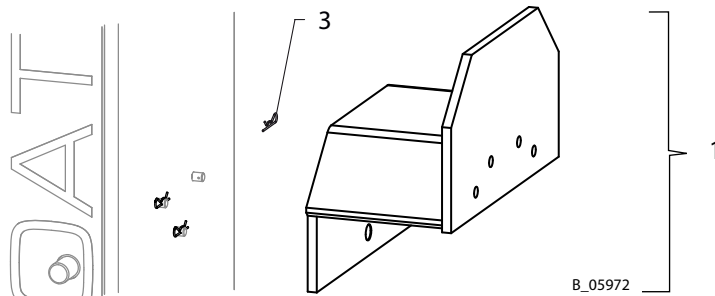

Spare parts list for hose holder

Pos	K	Stk	Order No.	Designation
1		1	353050	Hose holder, complete
3		3	9935049	Connection fields

◆ = Wearing parts

14.5.5 GUN HOLDER

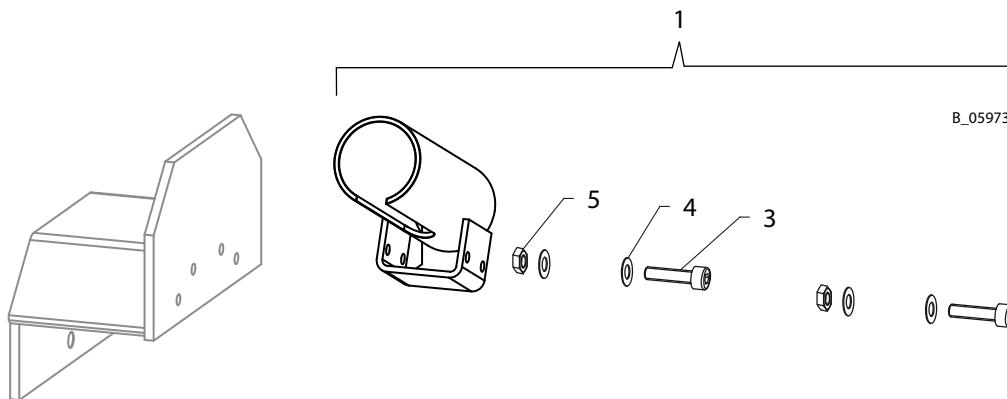

Spare parts list for gun holder

Pos	K	Stk	Order No.	Designation
1		1	2359097	Gun holder, complete
3		2	9900313	Hexagon socket cylinder head screw
4		4	9920102	Washer
5		2	9910107	Hexagon nut

◆ = Wearing parts

14.5.6 LEVEL MONITORING WITH ALARM HORN

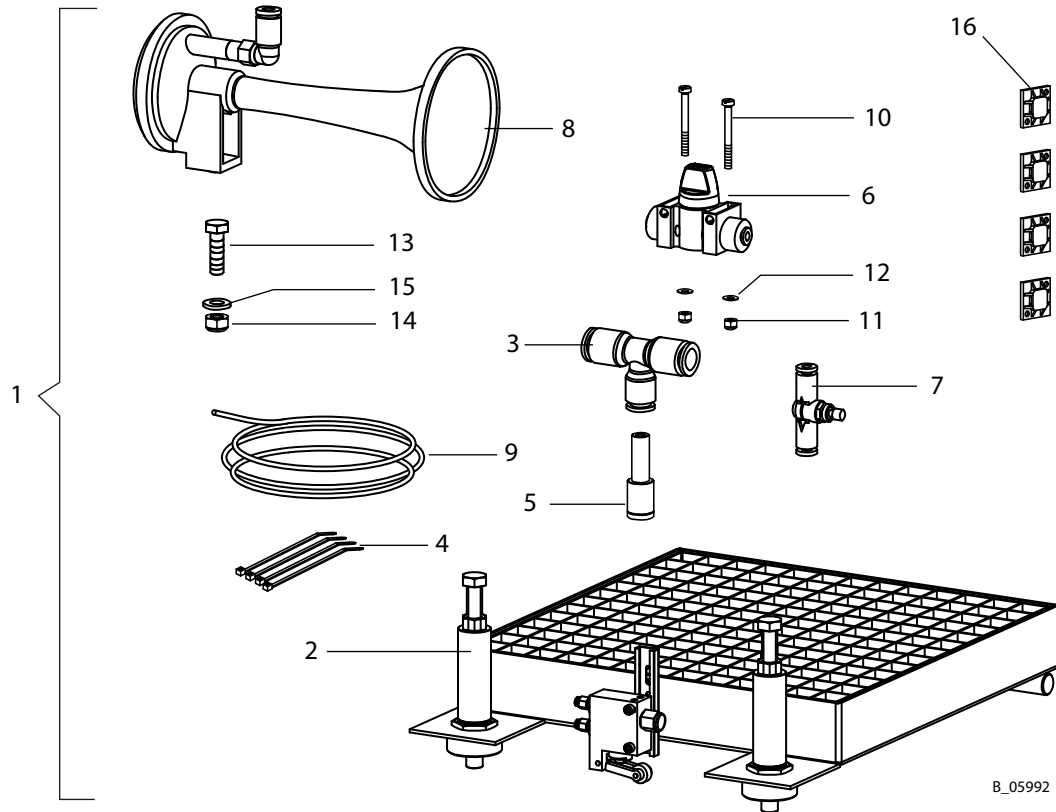

B_05992

Spare parts list for level monitoring with alarm horn

Pos	K	Stk	Order No.	Designation
1		1	353053	Level monitoring with alarm horn
2	◆	1	3207739	Niveau compensator, 30-liter
3		1	9999435	T-connection
4	◆	4	9950615	Cable tie
5		1	3151777	Straight reduction
6	◆	1	9999441	2/2-way valve
7	◆	1	9943023	Adjustable check-valve
8	◆	1	R037.00	Pneumatic alarm horn
9		5 m	9982072	Hose
10		2	9900704	Socket cap screw with slit
11		2	9910211	Hexagon nut with clamp
12		2	9920114	Washer
13		1	9900108	Hexagon screw
14		1	9910204	Hexagon nut with clamp
15		1	9920103	Washer
16		4	9950385	Fixing element

◆ = Wearing parts

14.5.7 D350 DRUM COVER

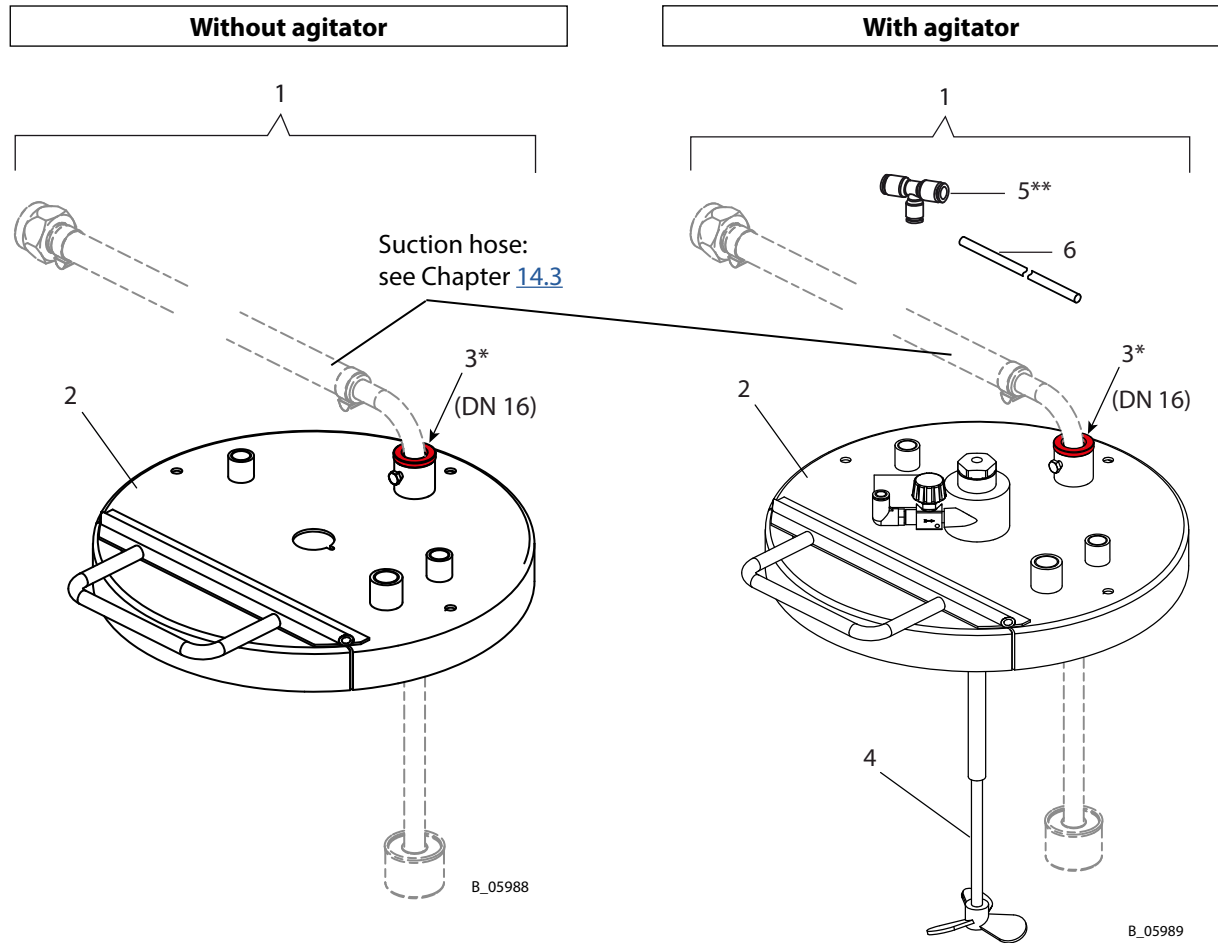

Spare parts list for D350 drum cover				Without agitator	With agitator
Pos	K	Stk	Designation	Order No.	Order No.
1		1	D350 drum cover	353054	353055
2		1	Cover, 365-A with plug	2304618	
3*		1	Bush	2367311	
4	◆	1	Agitator, P300HS-L400x16-D100-M32		2304533
5**		1	T-connection		9999435
6		2 m	Hose, black PUR 8/5.5		9982078

◆ = Wearing parts

* Pos. 3: For DN 16 suction hose.

** Pos. 5: Air is branched off from air inlet to control unit.

15 DECLARATION OF WARRANTY AND CONFORMITY

15.1 IMPORTANT NOTES ON PRODUCT LIABILITY

As a result of an EC regulation effective from January 1, 1990, the manufacturer shall only be liable for his product if all parts originate from him or are approved by him, and if the devices are properly mounted, operated and maintained.

The manufacturer will not be held liable or will only be held partially liable if third-party accessories or spare parts have been used.

With genuine WAGNER accessories and spare parts, you have the guarantee that all safety regulations are complied with.

15.2 WARRANTY CLAIM

Full warranty is provided for this device:

We will at our discretion repair or replace free of charge all parts which within 24 months in single-shift, 12 months in 2-shift or 6 months in 3-shift operation from date of receipt by the purchaser are found to be wholly or substantially unusable due to causes prior to the sale, in particular faulty design, defective materials or poor workmanship.

The type of warranty provided is such that the device or individual components of the device are either replaced or repaired as we see fit. The resulting costs, in particular shipping charges, road tolls, labor and material costs will be borne by us except where these costs are increased due to the subsequent shipment of the device to a location other than the address of the purchaser.

We do not provide warranty for damage that has been caused or contributed to for the following reasons:

Unsuitable or improper use, faulty assembly or commissioning by the purchaser or a third party, normal wear, negligent handling, defective maintenance, unsuitable coating products, substitute products and the influence of chemical, electrochemical or electrical agents, except when the damage is attributable to us.

Abrasive coating products such as red lead, emulsions, glazes, liquid abrasives, zinc dust paints and so forth reduce the service life of valves, packings, spray guns, nozzles, cylinders, pistons etc. Signs of wear traced back to these products are not covered by this warranty. Components that have not been manufactured by WAGNER are subject to the original warranty of the manufacturer.

Replacement of a component does not extend the period of warranty of the device.

The device should be inspected immediately upon receipt. To avoid losing the warranty, we or the supplier company are to be informed in writing about obvious faults within 14 days upon receipt of the device.

We reserve the right to have the warranty compliance met by a contracting company.

The services provided by this warranty are dependent on evidence being provided in the form of an invoice or delivery note. If the examination discovers that no warranty claim exists, the costs of repairs are charged to the purchaser.

It is clearly stipulated that this warranty claim does not represent any constraint on statutory regulations or regulations agreed to contractually in our general terms and conditions.

Wagner International AG

15.3 EC DECLARATION OF CONFORMITY

Herewith we declare that the supplied version of:

AquaCoat 5010/5020 System GM 5020EAW Manual Airspray

complies with the following guidelines:

2006/42/EC	2014/30/EU	2012/19/EU
2014/35/EU	2011/65/EU	--

Applied standards, in particular:

EN ISO 12100:2010
 EN 50059:1990
 EN 1953:2013
 EN ISO 4413:2010
 EN ISO 4414:2010
 EN 12621: 2006+A1: 2010
 EN 60204-1:2006+A1:2009+B:2010
 EN 61000-6-2:2005+B:2011
 EN 61000-6-4:2007+A1:2011
 EN ISO 9001:2008

Applied national technical standards and specifications, in particular:

DGUV 209-046
 DGUV 209-052

Identification: 

EC Declaration of Conformity

The EC Declaration of Conformity is enclosed with this product. If needed, further copies can be ordered through your WAGNER dealer by specifying the product name and serial number.

Order number: 2363961

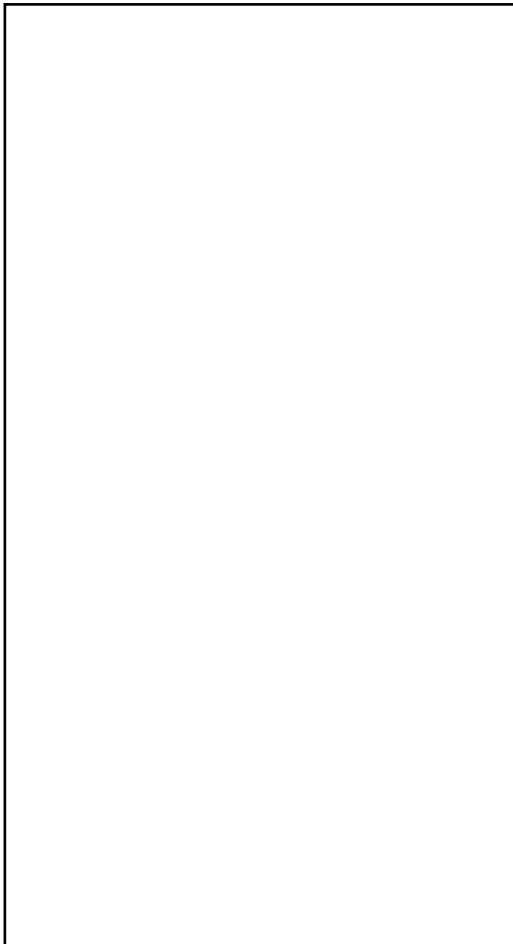

Order No. 2366717
Edition 02/2018

Germany

J. Wagner GmbH
Otto-Lilienthal-Str. 18
Postfach 1120

88677

Markdorf

Phone +49/ (0)7544 / 5050
Telefax +49/ (0)7544 / 505200
E-Mail ts-liquid@wagner-group.com

Switzerland

Wagner International AG
Industriestrasse 22

9450

Altstätten

Phone +41/ (0)71 / 757 2211
Telefax +41/ (0)71 / 757 2222

More contact addresses:
www.wagner-group.com

Subject to changes without notice