

Operating Manual

WAGNER

WAGNER

WAGNER

Tribo Manual Spray Gun

STOP DANGER



High Voltage!
Turn power off
before servicing!

CAUTION

Read rules for safe
operation and
instructions
carefully!

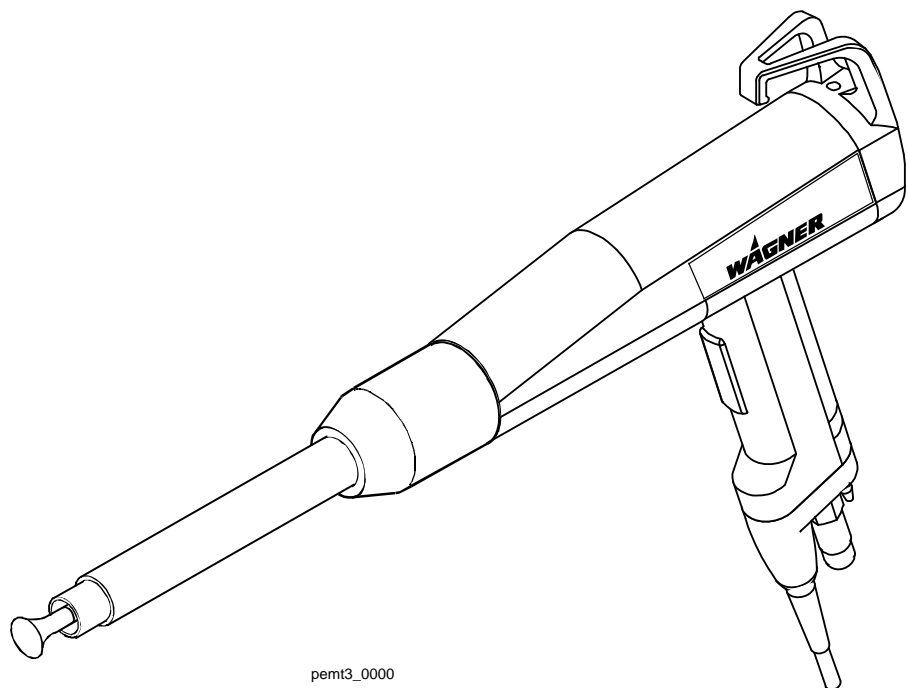

pemt3_0000



0351967

PEM-T3



WAGNER

WAGNER

WAGNER

WAGNER

WAGNER

Tribo manual spray gun

Article No. 0351019

00_Pemt3_Aufbau.doc

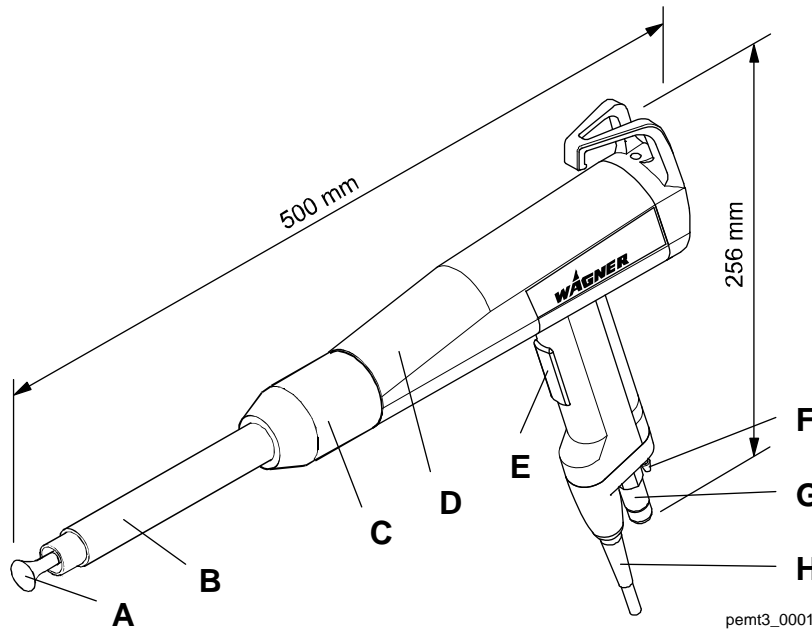

- | | | | |
|---|----------------|---|------------------------|
| A | Deflector cone | E | Trigger |
| B | Nozzle body | F | Tribo air connection |
| C | Outer nut | G | Powder hose connection |
| D | Spray gun body | H | Power supply |

The Tribo manual spray gun **PEM-T3** is used for powders suitable for **friction loading**.

The **PEM-T3** powder spray gun is used for industrial powder coating.

This spray gun can be operated with the following control units:

- | | | |
|-----------------------------|----------------------|---------------|
| • EPG 2008 | with powder injector | PI-P1 |
| • EPG-D1 | with powder injector | PI-F1 |
| • Control unit Bravo | with powder injector | PI-FM1 |

The powder feed and the Tribo air supply to the spray gun are activated by pressing the trigger.



Caution

The user must ensure, that the spray gun is only connected to **Wagner** equipment!
 High ambient temperatures must be avoided; in particular, the hoses **must** not be routed through factory areas exposed to direct sunlight!
 To provide a safeguard against unintentional use of the spray gun, the control unit **must** be turned off!

| Table of contents | | Page |
|--------------------------|--|-------------|
| 1. | Safety regulations | 5 |
| 1.1 | Safety hints..... | 5 |
| 1.2 | EC Declaration of conformity..... | 6 |
| 2. | Preparing the spray gun | 7 |
| 2.1 | Select the suitable nozzle system | 7 |
| 2.2 | Connecting the spray gun | 7 |
| 2.3 | Grounding..... | 8 |
| 3. | Working with the spray guns | 9 |
| 3.1 | Start up the spray gun | 9 |
| 3.2 | Switching off the spray gun | 9 |
| 3.3 | Carrying out a change of color | 10 |
| 4. | Maintenance and cleaning..... | 11 |
| 4.1 | Replacing the spray gun..... | 11 |
| 4.2 | Cleaning the spray gun and replace the wear parts..... | 12 |
| 4.3 | Mounting the gun extension | 13 |
| 4.4 | Disposal..... | 15 |
| 5. | Rectification of malfunctions | 16 |
| 6. | Technical data | 17 |
| 7. | Warranty..... | 18 |
| 8. | Scope of delivery and spare parts lists..... | 19 |
| 8.1 | How to order..... | 19 |
| 8.2 | Scope of delivery and spare parts list of PEM-T3 | 19 |
| 8.3 | Charging body (complete)..... | 20 |
| 8.4 | Wide fan spray nozzle | 20 |
| 8.5 | Gun extension | 21 |
| 8.6 | Charging body of PEM-T3 300..... | 22 |
| 8.7 | Outer tube | 23 |

00_...doc

This manual contains information and hints for the service, repair and maintenance of the equipment. The user must obey all the rules of operation found in this manual; failure to do so will render the warranty invalid.

Wagner powder systems are designed to meet the most stringent safety requirements. They can be operated in compliance with generally applicable safety codes and applicable national safety regulations.

Please pay particular attention to the parts marked by the following symbols. Follow the instructions exactly, in the interests of both your own safety and the correct functioning of the unit.



Warning

This symbol draws attention to the fact that if the operating instructions, working instructions, prescribed working sequences etc. are not followed exactly, this can lead to injury or even fatal accidents.



Caution

This symbol indicates that failure to follow the operating instructions, working instructions, prescribed working sequences etc. exactly can lead to material damage.



Hint

This symbol draws your attention to useful additional information and tips. Failure to observe these instructions can cause malfunctions.

1. Safety regulations

1.1 Safety hints

010101_.doc



Warning

This equipment can be dangerous if it is not operated in accordance with this operating manual!

There might be additional regulations to be observed, put into effect by governmental, state or other official agencies or local security (fire) departments!



Warning

Under no circumstance may persons with a cardiac pacemaker come close to the area between the tip of the spray gun and the work piece to be coated!

The following rules must be observed in order to ensure a safe and efficient use of the equipment:

- The user has to observe particularly the safety guidelines of the VdS, the local professional and security institutions.
- Trained and qualified personnel may only operate the electrostatic coating equipment.
- The spray gun may only be operated in powder coating booths or on powder coating stands that are equipped with a ventilation system.
- The user has to make sure, that the average powder/air concentration does not exceed 50% of the LEL (maximum allowed concentration of powder in air). If a reliable LEL value is not available, the average powder/air concentration may not exceed 10 g/m³.
- Over sprayed powder must be reliably collected.
- Adhere to the instructions given by the manufacturers and to the prevalent local laws on the environment when disposing of waste coating powder.
- The main power connection for operation of the Wagner powder equipment **must** be electrically interlocked with the exhaust system of the powder coating booth.
- In the event of faults or defects, repair work is to be performed at the user's discretion.
- The user must conduct periodic checks of the powder spray equipment (at least every year) with regard to explosion-protection.
- Repairs may only be carried out by trained technicians and may never be carried out in an explosion hazardous area. Protective measures against explosions must still be installed.
- The work area **must** have an electrostatically conductive floor (measured in accordance with EN 1081).
- All conductive parts in the work area **must** be electrostatically grounded (work area = 1 m around every spray location or opening in the booth).
- All persons inside the work area **must** wear electrostatically conductive footwear.
- Spray guns should be operated with bare hands! If gloves are used they **must** be made of conductive material.
- **Guideline 94/9/EC:** The device is suited for the applications it was designed for, even in explosion-hazard areas.

- **Wear suitable work clothing**
- **Use breathing protection or a visor for work which produces powder and when developing solvent steams:**
Avoid health dangers by inhalation and skin contacts of solvent steams and lacquer aerosols; Cornea injuries by splashes in the eye.
- **Check the equipment for damage**
Before operating the system, check if slightly damaged parts still function correctly. Check whether the moving parts operate properly, whether they jam and whether parts are damaged.
Damaged parts should be repaired or replaced by a Wagner customer service.



Warning

For your own safety, use only accessories and equipment listed in the operating manual. The use of individual parts other than those recommended in the operating manual may create a hazard to personal safety.

Use only original Wagner replacement parts!

Alteration or repair of Wagner original spare parts may cause fatal accidents or explosions in the coating system!

1.2 EC Declaration of conformity



Wagner hereby declares that the unit described in these operating instructions has been designed and manufactured according to the provisions of EU Directives 98/37/EC, 94/9/EC, 73/23 EEC and 89/336 EEC.

The following **European standards** were applied:

| | | |
|---------------|-------------------|--------------|
| EN 12100-1/-2 | EN 50281-1-1/-1-2 | EN 61000-6-1 |
| EN 61000-6-2 | EN 61000-6-3 | EN 60204-1 |
| EN 50053-2 | EN 50050 | EN 50177 |

The following **German standards** and/or Guidelines were applied:

BGI 764

The product includes an **EC declaration of conformity**. This can be ordered again if necessary from your WAGNER dealer by giving details of the product and serial number involved.

The number of the EC Declaration of Conformity is **0351967**.

2. Preparing the spray gun

2.1 Select the suitable nozzle system

0201_Duesenauswahl_tribo.doc

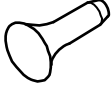
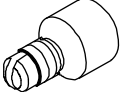
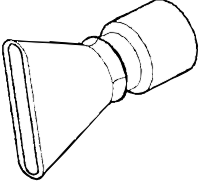
| Nozzle | Overview Application | Spray pattern |
|---|---|--|
| Deflector cone  | <ul style="list-style-type: none"> • Wire goods • Grid designs | Oval powder cloud: Size is dependent on the deflector cone diameter. For powder quantities from: 50 ... 300 g/min |
| Fan spray nozzle  | Difficult workpieces: <ul style="list-style-type: none"> • Undercuts • Profiles | Widely spread flat powder cloud. For powder quantities: from 50 ... 150 g/min |
| Wide fan spray nozzle  | Difficult workpieces: <ul style="list-style-type: none"> • Undercuts • Profiles | Widely spread flat powder cloud. For powder quantities: from 100 ... 250 g/min |

The part numbers are listed in chapter [8 "Scope of delivery and spare parts lists"](#).

2.2 Connecting the spray gun

Before you start making connections, switch off the powder feeding. Refer to the operating instructions of the corresponding control unit for this.

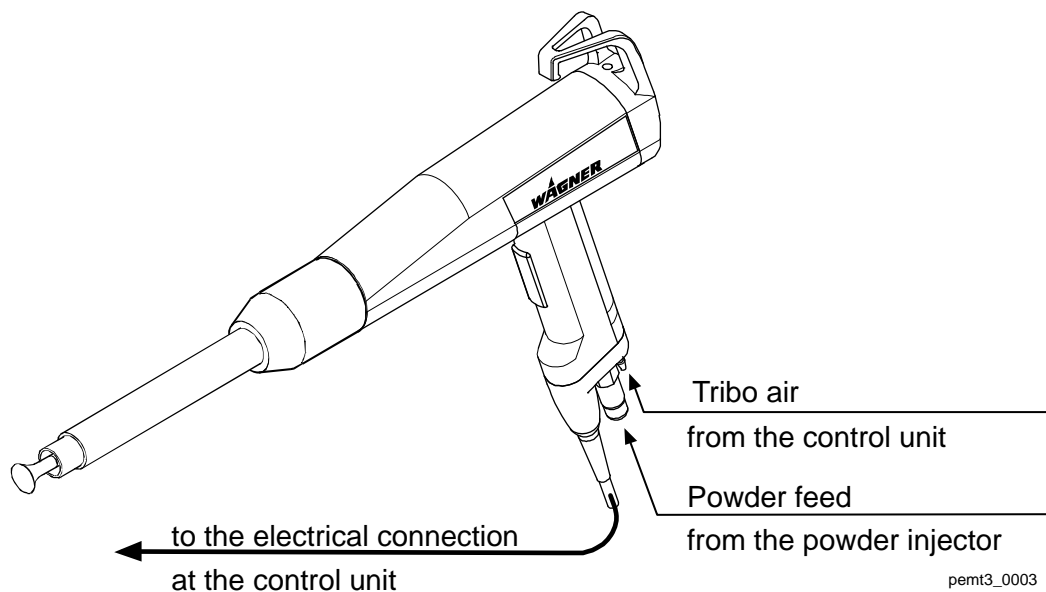

- Connect the spray gun to the Tribo current measuring or display module with the electrical cable.
- Connect the powder hose to the spray gun and to the powder injector.
- Connect the hose for Tribo air to the spray gun and to the control unit.

2.3 Grounding

For safety reasons, the **spray gun must** be properly grounded. This occurs through the electrical cable.

0203_.doc

Good grounding of the **workpiece** is also necessary for optimum powder coating.

A poorly grounded workpiece causes:

- dangerous electric charging of the workpiece
- back-spray onto spray gun and user
- uneven coating
- very bad wrap around



Warning

Sparks between workpiece and conveyor hooks (hangers) can occur if hooks or other hanger parts are not completely cleaned!

These sparks can cause heavy radio frequency interference.

3. Working with the spray guns

3.1 Start up the spray gun

- Switch on the control unit.
- Select the type of gun **Manual** and charging **Tribo** on the control unit.
- Refer to the operating instructions of the control unit for this.



Caution

To reduce wear, the total of feed air and dosage air **must** range between **3.5 - 6 Nm³/h!**

The total of feed air, dosage air and Tribo air should not exceed a maximum of **7.5 Nm³/h!**

- Hold the **manual gun** in the spray booth, press the trigger and set the powder volume and the powder speed to a test piece by adjusting the volume of feed air and dosage air.
- Only open the Tribo air until a Tribo current reading of 3 μ A is attained.



Caution

The Tribo air **must** be reduced or shut off if the Tribo current (charging current) exceeds **3.5 μ A!**

The charging current depends on the type of powder used and should ideally lie between 2.5 and 3.5 μ A.

3.2 Switching off the spray gun

The spray gun is switched off in different ways, depending on the type of powder injector.



Hint

The spray gun should be blown through (flushed) and cleaned from powder deposits with every interruption of work. In this way **powder deposits** and **surges** on switching on again are to a great extent avoided.

0302_.doc

The flushing procedure can be set on the control unit if the spray gun is connected to an **EPG-D1** or a **Control unit Bravo** in conjunction with the **PI-F1** powder injector. In this case the spray gun is blown free of powder as soon as the trigger is released.

If the spray gun is operated with an **EPG 2008** control unit and a **PI-P1** powder injector, proceed as follows:

- Release the trigger on the spray gun so that the powder feed and high voltage generator are switched off.
- Set the knob for the overall air quantity on the control unit **EPG 2008** to maximum. No more powder will be delivered when switching on again.
- Press the trigger on the spray gun so that the spray gun is blown free of powder.
- Switch off the control unit and secure against inadvertent switch on.

3.3 Carrying out a change of color

All parts carrying powder in the entire coating system **must** be **thoroughly** cleaned of powder deposits on a change of color. In the following, only the procedure for the spray gun is described. Instructions on cleaning the other components can be found in the appropriate operating instructions.

- Switch off the control unit and secure it against being switched on again.

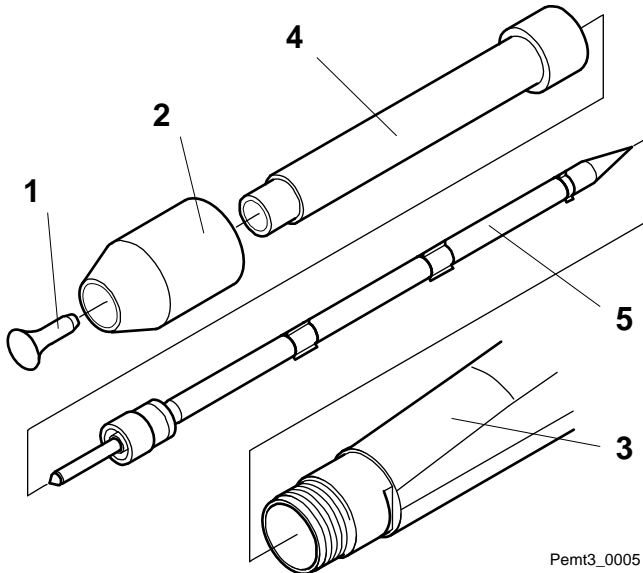

Pemt3_0005

- If you do not use automatic flushing:
 Release the trigger on the spray gun so that the powder supply and high voltage generation are switched off.
 Pull the powder injector out of the powder container's injector connection so that no powder can be delivered during flushing.
 Press the trigger on the spray gun so that the spray gun is blown free of powder.
 Switch the control unit off and secure it against being switched on unintentionally.

- Pull off the deflector cone **1** from the charging body **5**.
- Unscrew the outer nut **2** from the gun housing **3**.
- Carefully draw the nozzle body **4** out of the gun housing **3**.
- Carefully extract the charging body **5**.



Caution

Ensure in particular that none of the charging body's components are damaged when removing and replacing the wear parts!

- Clean the parts, which have been dismantled, and the spray gun from powder deposits.
- Carefully re-fit the charging body **5** and the nozzle body **4** in the gun housing **3** and tighten it up with the outer nut **2**.
- Slide the deflector cone **1** onto the charging body **5** again.

The spray gun is again ready for operation.

4. Maintenance and cleaning

4.1 Replacing the spray gun

0401_.doc

Before you commence the replacement of the spray gun any powder residue **must** be removed **thoroughly**.



Caution

Repair or replacement of the spray gun or parts of the spray gun are only allowed to be performed outside the hazard area and in a suitable place by specialist personnel!

The wearing parts in the spray gun, marked in the spare parts list with *, must be regularly checked and, if necessary replaced.

0401_Pemt3_Ausbauen.doc

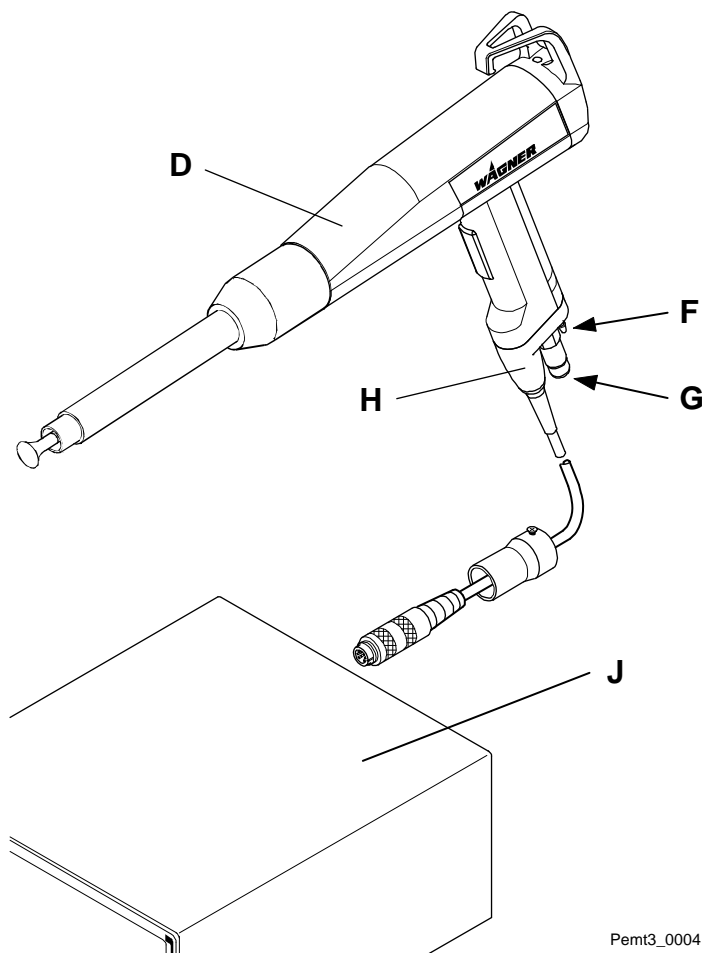

Pemt3_0004

- Switch off the control unit and/or high voltage generator.
- Disconnect the electrical cable **H** from the control unit **J**.
- Disconnect the powder feed hose **G** and Tribo air hose **F** from the spray gun **D**.

- Exchange the spray gun for a new one and assemble it in reverse order.

4.2 Cleaning the spray gun and replace the wear parts



Caution

Never place the spray gun or parts of it into any wet cleaning agent!

0402_Pemt3_Verschlaustausch.doc



Caution

While pulling out and replacing the wearing parts make sure that the parts of the charging body are not damaged.

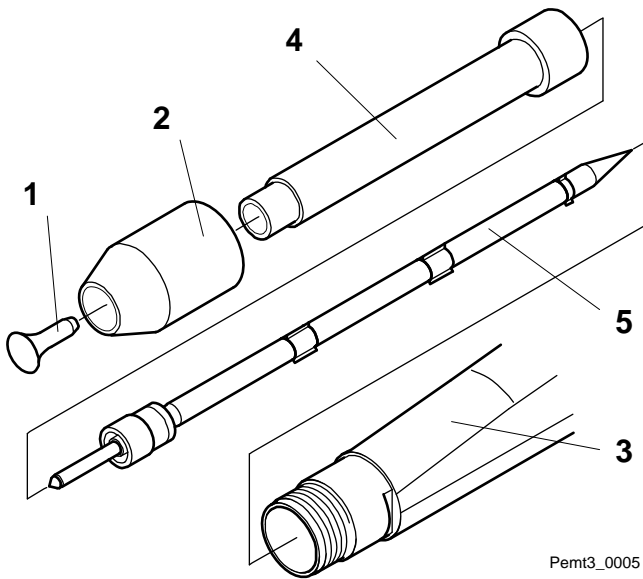

Pemt3_0005

- Pull the deflector cone 1 from the charging body 5.
- Unscrew the outer nut 2 from the gun housing 3.
- Carefully pull out the nozzle body 4 from the gun housing 3.
- Carefully pull out the charging body 5.
- Check the removed parts for wear. The **entire** charging body can be replaced with a **new** one during this procedure.

It is also possible to dismantle the charging body and merely replace the parts affected by wear.

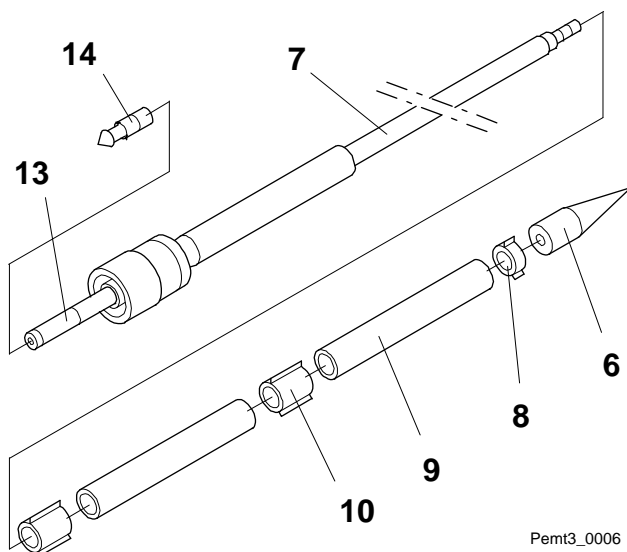

Pemt3_0006

- Carefully unscrew the tip 6 from the threaded bar 7 and dismantle the charging body.
- Unscrew the air nozzle 14 from the deflector cone rod 13 if worn and replace it with a **new** one.
- Complete clean residual powder from all parts.
- Replace worn parts with new ones.
- Reassembly of the charging body.
- Carefully push the charging body back into gun and reassemble the gun.

4.3 Mounting the gun extension



Caution

In order to install a gun extension, the spray gun **must** always be thoroughly clean!
It is even better to use a new spray gun.

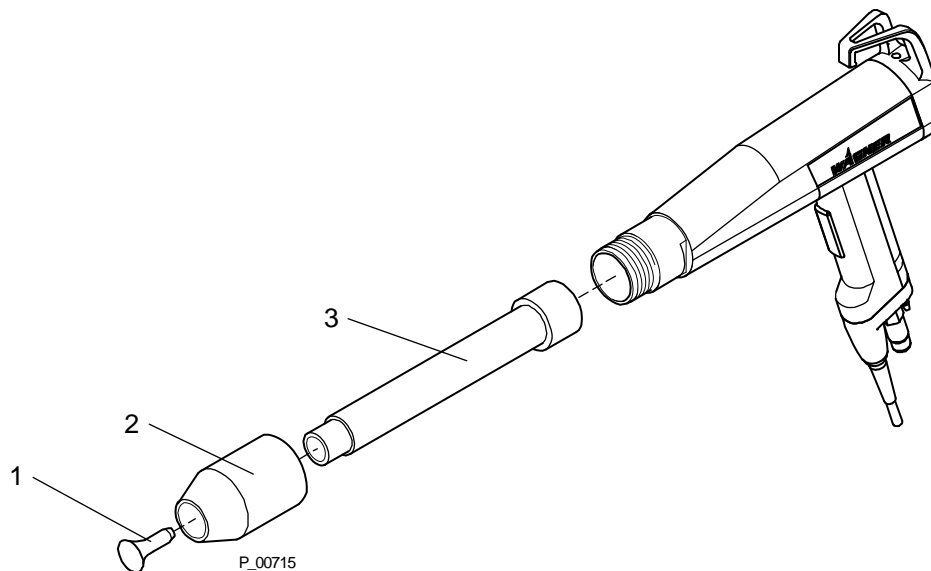

- Pull the deflector cone/fan spray nozzle 1 from the nozzle body 3.
- Unscrew the outer nut 2 from the gun housing.
- Pull the nozzle body 3 from the gun housing.

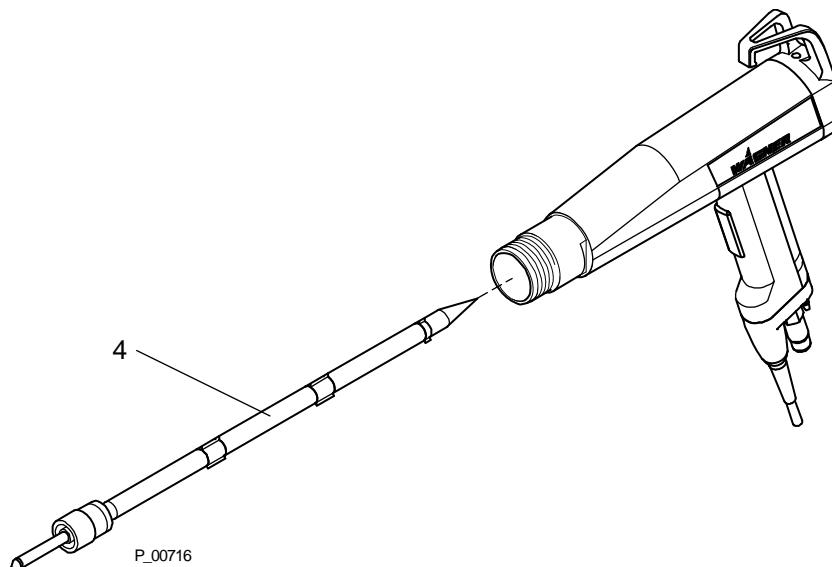

- Pull out the charging body 4 from the gun housing.

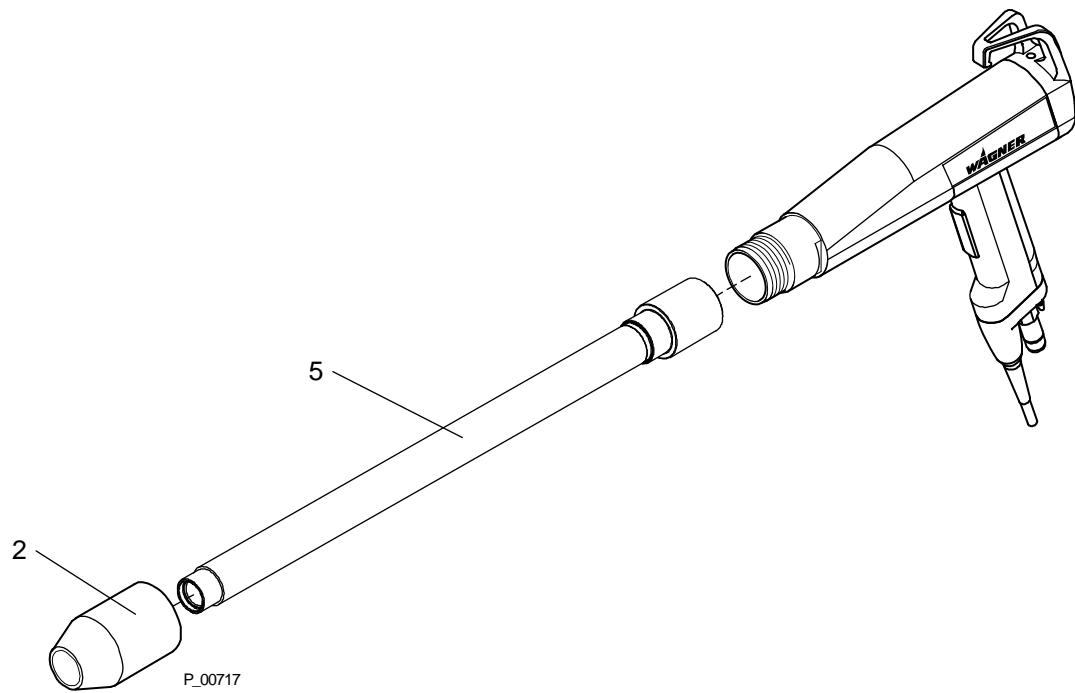

- Insert outer tube 5 into the gun housing and secure it with outer nut 2.

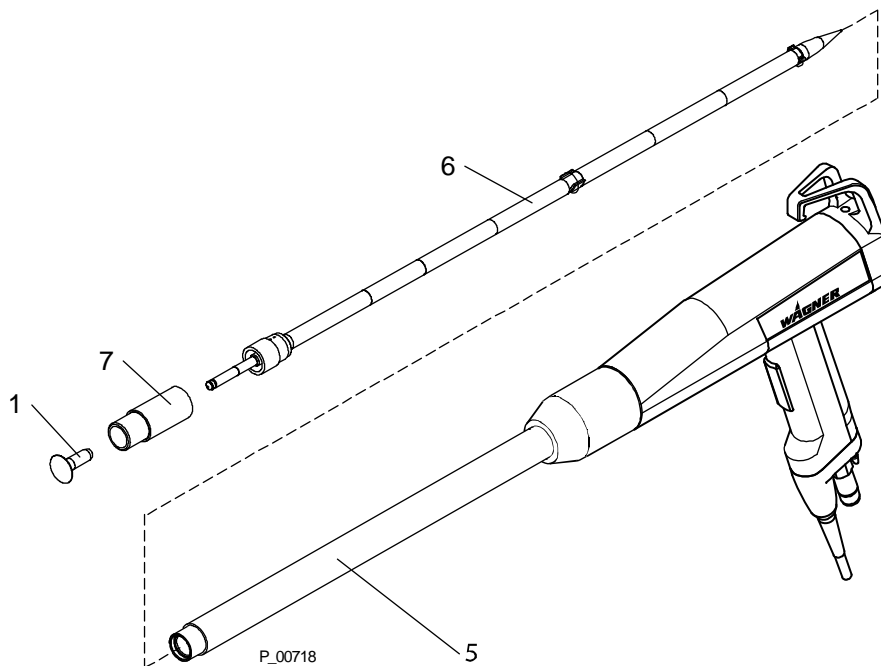

- Insert charging body 6 into the outer tube 5 and push it in as far as it will go.
- Push adapter 7 onto outer tube 5 as far as it will go.
- Locate deflector cone / column nozzle 1 onto adapter 7.

4.4 Disposal

04_Entsorgung.doc

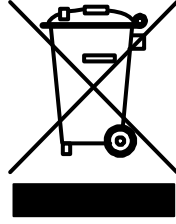
| | |
|---|--|
|  | <p>Only for EU countries</p> <p>Do not dispose of electric tools together with household waste material!</p> <p>In observance of the European Directive 2002/96/EC on waste electrical and electronic equipment and implementation in accordance with national law, this product is not to be disposed of together with household waste material but must be recycled in an environmentally friendly way!</p> |
|---|--|

Wagner or one of our dealers will take back your used Wagner waste electrical or electronic equipment and will dispose of it for you in an environmentally friendly way. Please ask your local Wagner service center or dealer for details or contact us direct.

5. Rectification of malfunctions

| Malfunction | Cause | Rectification |
|---|--|---|
| No Tribo current (e.g. no wraparound or no powder adhesion) | <ul style="list-style-type: none"> - Inadequate or no powder charging - Electrical cable from spray gun to control unit faulty - Tribo current measuring or display module defective - Powder-conveying parts in spray gun worn | <ul style="list-style-type: none"> - Contact Wagner Service - Replace worn parts |
| Poor wrap-around Back-spray | <ul style="list-style-type: none"> - Inadequate or no ground | <ul style="list-style-type: none"> - See chapter "Grounding" |
| Powder outlet uneven or inadequate | <ul style="list-style-type: none"> - Soiling - Powder sintering or powder-conveying parts in spray gun worn - Blow through parts carrying powder - Feed air / dosage air ratio incorrect - Wear on powder injector nozzle | <ul style="list-style-type: none"> - Blow through parts carrying powder - Clean parts carrying powder and replace if necessary - See operating instructions for the related devices connected - Adjust at control unit - Replace worn parts in the powder injector 1.) |
| Spray pattern is uneven | <ul style="list-style-type: none"> - Parts of nozzle system worn | <ul style="list-style-type: none"> - Replace worn parts |

1.) You will find the wearing parts and spare parts in the operating instructions for the powder injector.

6. Technical data

Adjusting

Weight: 500 g

06_Tribopistolendaten.doc

Electrical:

Design: as per EN 50177 and EN 50050

Protection class: IP 54

Pneumatic:

Input air pressure (Tribo air): max. 43.5 psi (3 bar)

Powder output quantity: max. 300 g/min

06_.doc

Required compressed air quality:

| Quality class | Compressed air quality according to ISO 8573.1 | |
|---------------|--|--|
| 5 | Max. residual water: (pressure dew point in °F at 100 psi / °C at 700 kPa) | +44.6 °F / +7 °C |
| 2 | Max. oil contents: | 0.1 mg oil/m ³ / 0.1 oz/ft ³ |
| 3 | Max. concentration: | 5 mg/m ³ / 5 oz/ft ³ |
| 3 | Max. particle size: | 5 μm / 5 microns |

Ambient conditions:

If low temperature powders are used, the ambient temperature may have to be lower than 86 °F (30 °C).



Volume measures:

For volumes, specified in Nm³ (standard cubic meters). One cubic meter of a gas at 32 °F (0 °C) and 1.013 bar is called norm cubic meter.

1 Nm³/h = 35.3 ft³/h; 1 bar = 14.504 psi

7. Warranty

08_.doc

What is covered by this warranty?

Faulty or defective parts are replaced according to our general delivery conditions.

Within the applicable warrant period, Wagner will repair or replace, at our option, defective parts without charge if such parts are returned with transportation charges prepaid to the nearest authorized service center. If Wagner is unable to repair this product so as to conform to this Limited Warranty after a reasonable number of attempts, Wagner will provide, at our option, either a replacement for this product or a full refund of the purchase price of this product.

These remedies are the sole and exclusive remedies available for breach of express and implied warranties.

What is not covered by this warranty?

This warranty does not cover any of the following damages or defects:

1. Damages or defects caused by use or installation of repair or replacement parts or accessories not manufactured by Wagner,
2. Damages or defects caused by repair performed by anyone other than a Wagner authorized service center, or
3. Damages or defects caused by or related to abrasion, corrosion, abuse, misuse, negligence, accident, normal wear, faulty installation or tampering in a manner which impairs normal operation.

Limitation of remedies:

IN NO CASE SHALL WAGNER BE LIABLE FOR ANY INCIDENTAL, SPECIAL OR CONSEQUENTIAL DAMAGES OR LOSS, INCLUDING TRANSPORTATION COSTS, WHETHER SUCH DAMAGES ARE BASED UPON A BREACH OF EXPRESS OR IMPLIED WARRANTIES, BREACH OF CONTRACT, NEGLIGENCE, STRICT TORT, OR ANY OTHER LEGAL THEORY.

Disclaimer of implied warranties:

THE FOREGOING WARRANTIES ARE IN LIEU OF ALL OTHER WARRANTIES, EXPRESS OR IMPLIED, INCLUDING BUT NOT LIMITED TO THE IMPLIED WARRANTIES OF MERCHANTABILITY AND FITNESS FOR A PARTICULAR PURPOSE.

No ability to transfer:

This warranty is extended to the original purchaser only and is not transferable.

Your rights under state law:

Some states do not allow limitations on how long an implied warranty lasts or the exclusion of incidental or consequential damages, so the above limitation and exclusion may not apply to you. This warranty gives you specific legal rights; you may also be entitled to other rights, which vary from state to state.

8. Scope of delivery and spare parts lists

8.1 How to order

0901_.doc

Faulty and unserviceable parts are replaced in accordance with our General Terms and Conditions of Delivery.

In order to be able to guarantee safe and smooth spare parts delivery, the following information is necessary:

- Invoicing address
- Delivery address
- Name of contact persons for check back
- Type of delivery
- Quantity ordered, article number and designation

8.2 Scope of delivery and spare parts list of PEM-T3

0351019

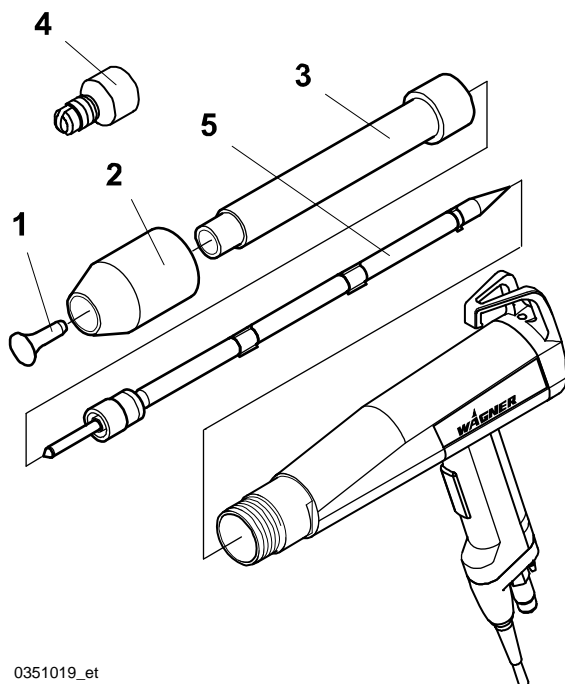

0351019_et

| Item | Art. No. | Designation |
|------|----------------|--------------------------------|
| -- | 0351019 | Tribo manual gun PEM-T3 |
| 1 | 0259474 * | Deflector cone (Ø22) |
| 1 | 0259475 * | Deflector cone (Ø28) *** |
| 2 | 0351654 | Outer nut Tribo ET |
| 3 | 0351581 | Nozzle body |
| 4 | 0260928 * | Fan spray nozzle ** |
| 5 | 0260629 * | Charging body (complete) |

* Wearing part

** Only available as a set

*** Special accessory

8.3 Charging body (complete)

0260629

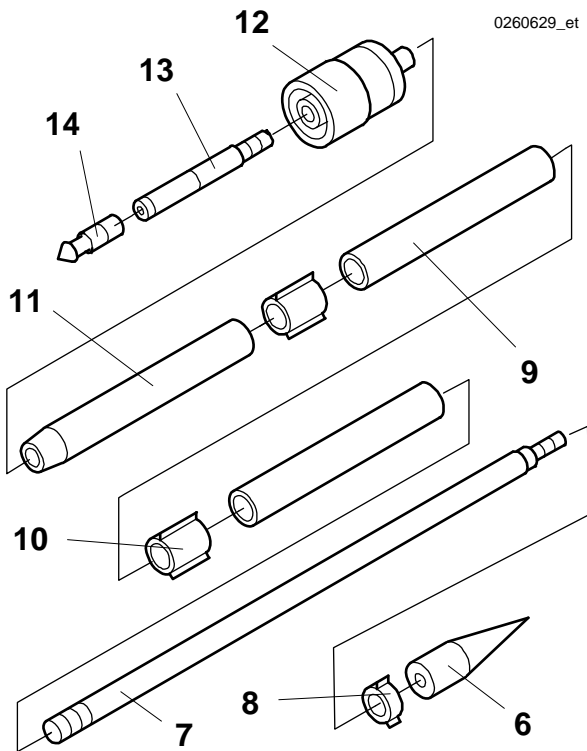

| Item | Art. No. | Designation |
|------|----------------|---------------------------------|
| - - | 0260629 | Charging body (complete) |
| 6 | 0260472 * | Tip |
| 7 | 0260473 | Threaded bar |
| 8 | 0260474 * | Ring |
| 9 | 0260471 * | Charging tube |
| 10 | 0260476 * | Support ring |
| 11 | 0260470 * | Rod |
| 12 | 0260463 * | Central air supply |
| 13 | 0260469 * | Deflector cone rod |
| 14 | 0260632 * | Air nozzle (complete) |

* Wearing part

8.4 Wide fan spray nozzle

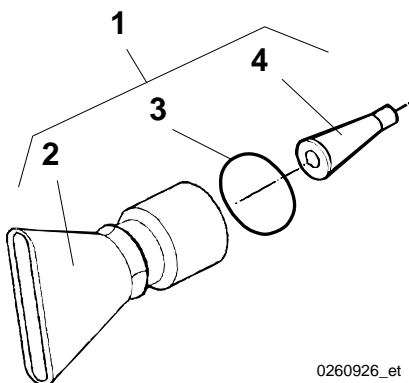

| Item | Art. No. | Designation |
|----------|------------------|---------------------------------|
| 1 | 0260926 * | Wide fan spray nozzle ** |
| 2 | 0260280 * | Wide fan spray nozzle |
| 3 | 9971037 * | O-ring 22x1,5 |
| 4 | 0260627 * | Deflector cone Ø13 |

* Wearing part

** Only available as a set

8.5 Gun extension

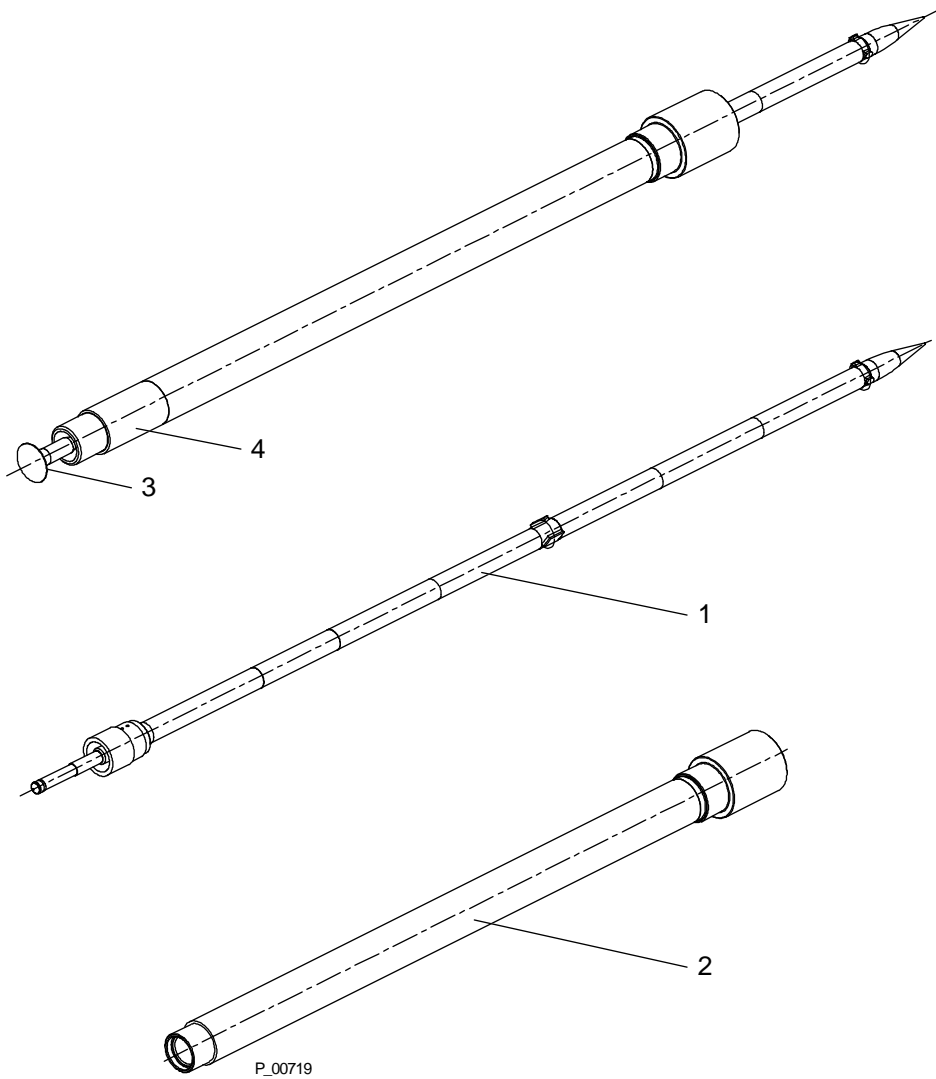

| Item | Art. No. | Designation |
|------|----------------|-----------------------------|
| -- | 0260934 | Gun extension 300 mm |
| 1 | 0260935 * | Charging body PEM-T3 ET |
| 2 | 0260936 * | Outer tube PEM-T3 ET |
| 3 | 0259474 * | Deflector cone (Ø22) |
| 4 | 0259479 | Adapter |

8.6 Charging body of PEM-T3 300

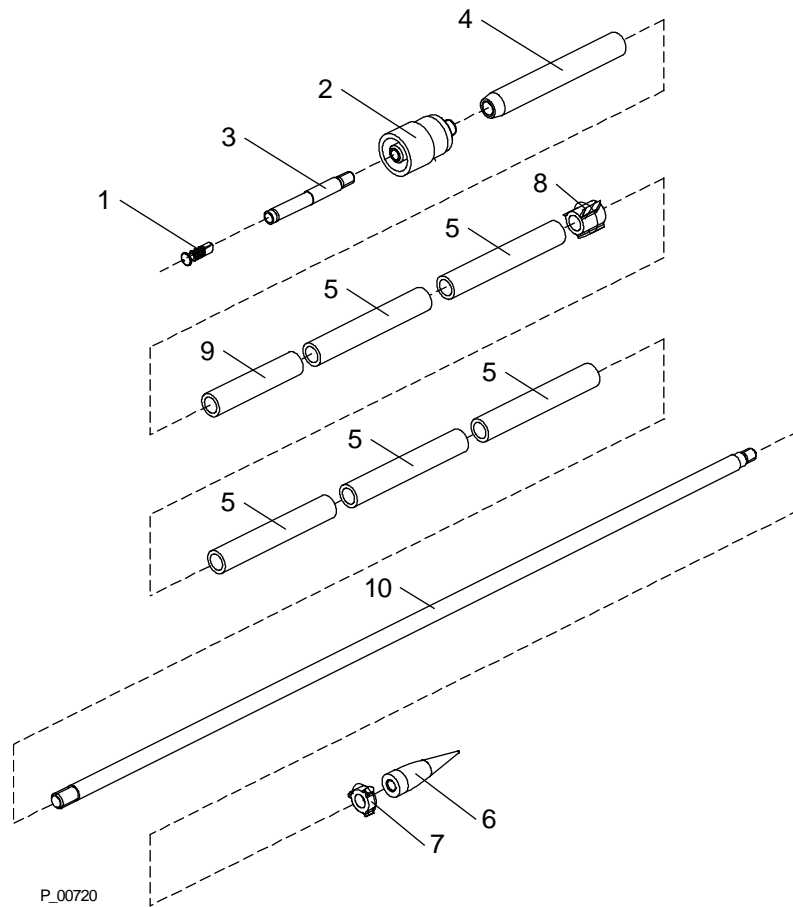

| Item | Art. No. | Designation |
|------|----------------|---------------------------------|
| -- | 0260935 | Charging body PEM-T3 300 |
| 1 | 0260632 * | Air nozzle (complete) |
| 2 | 0260463 * | Central air supply |
| 3 | 0260469 * | Deflector cone rod |
| 4 | 0260470 * | Rod |
| 5 | 0260471 * | Charging tube |
| 6 | 0260472 * | Tip |
| 7 | 0260474 * | Ring |
| 8 | 0260476 * | Support ring |
| 9 | 0260657 * | Charging tube |
| 10 | 0260658 | Threaded bar |

* Wearing part

8.7 Outer tube

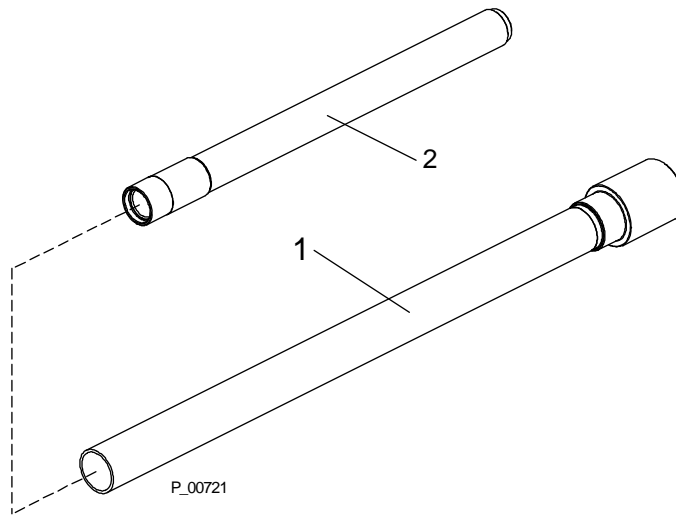

| Item | Art. No. | Designation |
|------|----------------|-----------------------------|
| -- | 0260936 | Outer tube T3 300 ET |
| 1 | 0260655 | Outer tube T300 |
| 2 | 0260656 | Powder tube |



ADDRESSES

Germany

J. WAGNER GmbH
Otto-Lilienthal-Str. 18
D-88677 Markdorf

Phone +49(0)7544/505-0
Fax +49(0)7544/505-200

Switzerland

J. WAGNER AG
Postfach 109
Industriestrasse 22
CH-9450 Altstätten

Phone +41(0)71/7572211
Fax +41(0)71/7572222

Austria

J. WAGNER GmbH
Otto-Lilienthal-Str. 18
Postfach 1120
D- 88677 Markdorf

Phone: ++49/ (0)7544 / 5050
Fax: ++49/ (0)7544 / 505200

Netherlands

Wagner Systemen Nederland B.V.
Proostwetering 105 C
NL-3543 AC UTRECHT

Phone +31(0)30/2410688
Fax +31(0)30/2410765

Belgium

Estee Industries
Leenbeekstraat 9
B-9770 Kruishoutem

Phone +32(0)9/3885410
Fax +32(0)9/3885440

Denmark

WAGNER Powder Systems Scvandinavia
Juupajokivej 8
DK-8850 Bjerringbro

Phone +45 7023 2052
Fax +45 8668 2052

Sweden

WAGNER Powder Systems Scandinavia AB
Hedenstorpsvägen 4
Sverige - 55593 Jönköping

Phone +46(0)36/341590
Fax +46(0)36/368580

Great Britain

WAGNER Spraytech (UK) Ltd.
Unit 3 Haslemere Way
Tramway Industrial Estate
UK-Banbury, Oxon OX 16 8TY

Phone +44-1295-265353
Fax +44-1295-269861

USA

WAGNER Systems Inc.
300 Airport Road, Unit 1
Elgin, IL 60123

Phone +1(0)630/503-2378
Fax +1(0)630/503-2377

Japan

WAGNER- HOSOKAWA Micron Ltd.
No. 9, 1-Chome
Shodal Tajka, Hirakata-Shi
Osaka 673-1132

Phone +81(0)728/566751
Fax +81(0)728/573722

China

WAGNER SPRAYTECH SHANGHAI CO LDT.
4th Flr, No. 395 Jiangchangxi Road
Shibei Industrial Zone
Shanghai, 200436

Phone +86(0)2166521858
Fax +86(0)2166529819

France

J. Wagner France SARL
B.P. 75, 5, Avenue du 1er Mai
F-91122 Palaiseau-Cédex

Phone +33(0)825/011111
Fax +33(0)1/69817257

Italy

WAGNER Itep S.p.A.
Via Santa Vecchia, 109
I-22049 Valmadrera - LC

Phone +39/0341/212211
Fax +39/0341/210200

Spain

WAGNER Spraytech Iberia S.A.
P.O.Boc, 132, Crtra. N-340, Km. 1245,4
E-08750 Molins de Rei (Barcelona)

Phone +34(0)93/6800028
Fax +34(0)93/6800555

The logo for CET, consisting of the letters 'CET' in a bold, italicized, sans-serif font.

DISTRIBUTED BY COATING EQUIPMENT TECHNOLOGY, INC