

# BINKS MODEL 7™ SPRAY GUN (6100-XXXX-X)



Your new Binks spray gun is exceptionally rugged in construction, and is built to stand up under hard, continuous use. However, like any other fine precision instrument, its most efficient operation depends on a knowledge of its construction, operation, and maintenance. Properly handled and cared for, it will produce beautiful, uniform finishing results long after other spray guns have worn out.

## TYPES OF INSTALLATION

### SIPHON FEED CUP HOOKUP

Air pressure for atomization is regulated at extractor. The amount of fluid is adjusted by fluid control screw on gun, viscosity of paint, and air pressure (see figure 1).

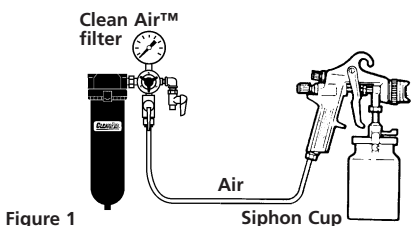

Figure 1

### PRESSURE FEED CUP HOOKUP

For fine finishing with limited spraying.

Air pressure for atomization is regulated at extractor; fluid pressure at cup regulator. For heavy fluids and internal mix nozzle spraying, fluid adjusted by control screw on gun.

Pressure cup also available less regulator (see figure 2).

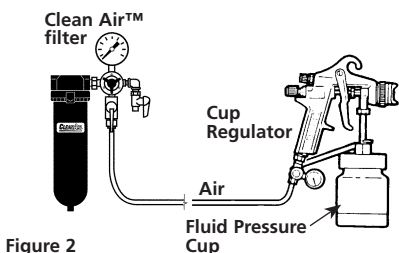

Figure 2



### PRESSURE FEED TANK HOOKUP

For medium production spraying (single regulator).

Air pressure for atomization is regulated at extractor, fluid pressure at tank regulator (see figure 3).

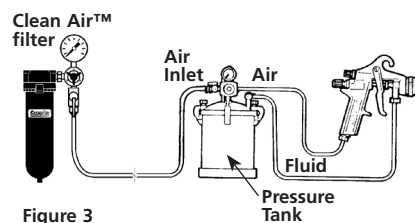

Figure 3

### PRESSURE FEED TANK HOOKUP

For portable painting operations (double regulator).

Air pressure for atomization and fluid supply is regulated by two individual air regulators on tank (see figure 4).

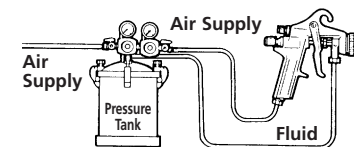

Figure 4

### PRESSURE FEED CIRCULATING HOOKUP

For heavy production spraying.

Air pressure atomization regulated at extractor. Fluid pressure regulated at fluid regulator (see figure 5).

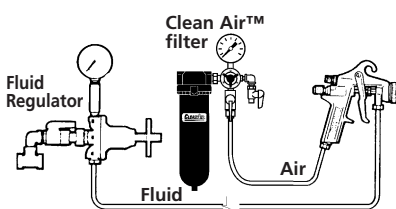

Figure 5

In this part sheet, the words **WARNING**, **CAUTION** and **NOTE** are used to emphasize important safety information as follows:

## **WARNING**

Hazards or unsafe practices which could result in severe personal injury, death or substantial property damage.

## **CAUTION**

Hazards or unsafe practices which could result in minor personal injury, product or property damage.

## **NOTE**

Important installation, operation or maintenance information.

## **WARNING**

### Read the following warnings before using this equipment.



#### **READ THE MANUAL**

Before operating finishing equipment, read and understand all safety, operation and maintenance information provided in the operation manual.



#### **OPERATOR TRAINING**

All personnel must be trained before operating finishing equipment.



#### **EQUIPMENT MISUSE HAZARD**

Equipment misuse can cause the equipment to rupture, malfunction, or start unexpectedly and result in serious injury.



#### **LOCK OUT / TAG-OUT**

Failure to de-energize, disconnect, lock out and tag-out all power sources before performing equipment maintenance could cause serious injury or death.



#### **AUTOMATIC EQUIPMENT**

Automatic equipment may start suddenly without warning.



#### **PRESSURE RELIEF PROCEDURE**

Always follow the pressure relief procedure in the equipment instruction manual.



#### **KEEP EQUIPMENT GUARDS IN PLACE**

Do not operate the equipment if the safety devices have been removed.



#### **KNOW WHERE AND HOW TO SHUT OFF THE EQUIPMENT IN CASE OF AN EMERGENCY**



#### **WEAR SAFETY GLASSES**

Failure to wear safety glasses with side shields could result in serious eye injury or blindness.



#### **INSPECT THE EQUIPMENT DAILY**

Inspect the equipment for worn or broken parts on a daily basis. Do not operate the equipment if you are uncertain about its condition.



#### **NEVER MODIFY THE EQUIPMENT**

Do not modify the equipment unless the manufacturer provides written approval.



#### **NOISE HAZARD**

You may be injured by loud noise. Hearing protection may be required when using this equipment.



#### **PROJECTILE HAZARD**

You may be injured by venting liquids or gases that are released under pressure, or flying debris.



#### **PINCH POINT HAZARD**

Moving parts can crush and cut. Pinch points are basically any areas where there are moving parts.



#### **STATIC CHARGE**

Fluid may develop a static charge that must be dissipated through proper grounding of the equipment, objects to be sprayed and all other electrically conductive objects in the dispensing area. Improper grounding or sparks can cause a hazardous condition and result in fire, explosion or electric shock and other serious injury.



#### **WEAR RESPIRATOR**

Toxic fumes can cause serious injury or death if inhaled. Wear a respirator as recommended by the fluid and solvent manufacturer's Safety Data Sheet.



#### **TOXIC FLUID & FUMES**

Hazardous fluid or toxic fumes can cause serious injury or death if splashed in the eyes or on the skin, inhaled, injected or swallowed. LEARN and KNOW the specific hazards or the fluids you are using.



#### **FIRE AND EXPLOSION HAZARD**

Improper equipment grounding, poor ventilation, open flame or sparks can cause a hazardous condition and result in fire or explosion and serious injury.



#### **MEDICAL ALERT**

Any injury caused by high pressure liquid can be serious. If you are injured or even suspect an injury:

- Go to an emergency room immediately.
- Tell the doctor you suspect an injection injury.
- Show the doctor this medical information or the medical alert card provided with your airless spray equipment.
- Tell the doctor what kind of fluid you were spraying or dispensing.



#### **GET IMMEDIATE MEDICAL ATTENTION**

To prevent contact with the fluid, please note the following:

- Never point the gun/valve at anyone or any part of the body.
- Never put hand or fingers over the spray tip.
- Never attempt to stop or deflect fluid leaks with your hand, body, glove or rag.
- Always have the tip guard on the spray gun before spraying.
- Always ensure that the gun trigger safety operates before spraying.



CA PROP  
**65**

#### **PROP 65 WARNING**

WARNING: This product contains chemicals known to the State of California to cause cancer and birth defects or other reproductive harm.

**IT IS THE RESPONSIBILITY OF THE EMPLOYER TO PROVIDE THIS INFORMATION TO THE OPERATOR OF THE EQUIPMENT. FOR FURTHER SAFETY INFORMATION REGARDING THIS EQUIPMENT, SEE THE GENERAL EQUIPMENT SAFETY BOOKLET (77-5300).**

Binks reserves the right to modify equipment specification without prior notice.

## Binks MODEL 7™ SPRAY GUN

### GUN HANDLING

The first requirement for a good resultant finish is the proper handling of the gun. The gun should be held perpendicular to the surface being covered and moved parallel with it. The stroke should be started before the trigger is pulled and the trigger should be released before the stroke is ended. This gives accurate control of the gun and material.

The distance between gun and surface should be 6 to 12 inches depending on material and atomizing pressure. The material deposited should always be even and wet. Lap each stroke over the preceding stroke to obtain a uniform finish.

### NOTE

To reduce overspray and obtain maximum efficiency, always spray with the lowest possible atomizing air pressure.

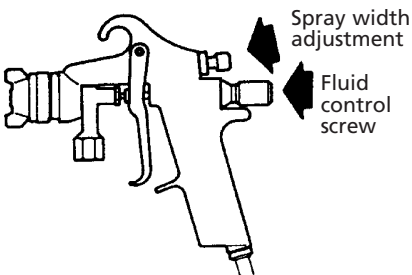
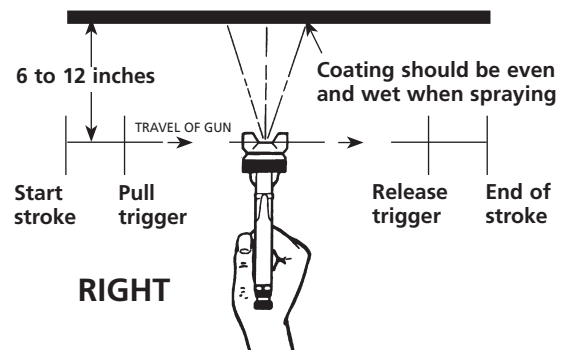
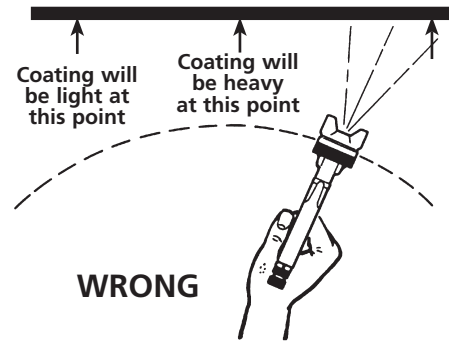

**Spray width adjustment:** Turn clockwise for round, counterclockwise for fan.

**Fluid control screw:** Turn clockwise to decrease flow, counterclockwise to increase flow.

As width of spray is increased, more material must be allowed to pass through the gun to obtain the same coverage on the increased area.

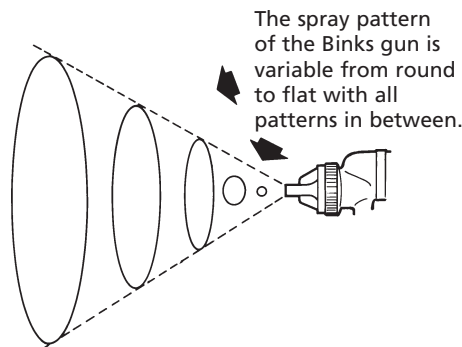

### SIPHON SPRAYING

Set atomization pressure at approximately 50 PSI for lacquer and 60 PSI for enamel. Test spray. If the spray is too fine, reduce the air pressure or open fluid control screw. If the spray is too coarse, close the fluid control screw. Adjust the pattern width and repeat adjustment of spray if necessary.

In normal operation, the wings on the nozzle are horizontal as illustrated here.

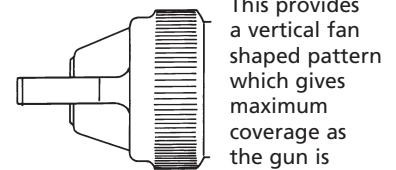

This provides a vertical fan shaped pattern which gives maximum coverage as the gun is moved back and forth parallel to the surface being finished.

### PRESSURE SPRAYING



After selecting correct size fluid orifice, set fluid pressure for desired flow. Open atomization air and test spray. If spray is too fine, reduce air pressure. If spray is too coarse, raise air pressure. Adjust pattern width and repeat adjustment of spray.

Keeping fluid control screw in open position will reduce fluid needle wear.

### NOTE

To reduce overspray and obtain maximum efficiency, always spray with the lowest possible atomizing air pressure.

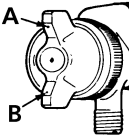
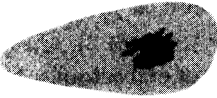
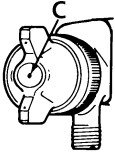
## FAULTY PATTERNS AND HOW TO CORRECT THEM

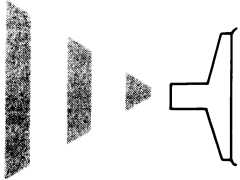
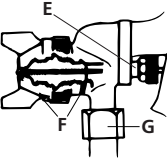
PATTERN	CAUSE	CORRECTION
	<p>Dried material in side-port "A" restricts passage of air. Greater flow of air from cleaner side-port "B" forces fan pattern in direction of clogged side.</p> 	<p>Dissolve material in side-ports with thinner, then blow gun clean. Do not poke into openings with metal instruments.</p>
	<p>Dried material around the outside of the fluid nozzle tip at position "C" restricts the passage of atomizing air at one point through the center opening of air nozzle and results in pattern shown. This pattern can also be caused by a loose air nozzle.</p> 	<p>Remove air nozzle and wipe off fluid tip using rag wet with thinner. Tighten air nozzle.</p>
	<p>A split spray or one that is heavy on each end of a fan pattern and weak in the middle is usually caused by:</p> <ol style="list-style-type: none"> <li>(1) Too high an atomization air pressure</li> <li>(2) Attempting to get too wide a spray pattern with thin material.</li> </ol>	<p>Reducing air pressure will correct cause (1). To correct cause (2), open material control to full position by turning to left. At the same time, turn spray width adjustment to right. This will reduce width of spray, but will correct split spray pattern.</p>
	<ol style="list-style-type: none"> <li>(1) Dried out packing around material needle valve permits air to get into fluid passageway. This results in spitting.</li> <li>(2) Dirt between fluid nozzle seat and body or loosely installed fluid nozzle will make gun spit.</li> <li>(3) A loose or defective swivel nut on siphon cup or material hose can cause spitting.</li> </ol>	 <p>To correct cause (1) back up knurled nut (E), place two drops of gun lube on packing, replace nut and tighten with fingers only. In aggravated cases, replace packing.</p> <p>To correct cause (2), remove fluid nozzle (F), clean back of nozzle and nozzle seat in gun body using rag wet with thinner, replace nozzle and draw up tightly against body.</p> <p>To correct cause (3), tighten or replace swivel nut.</p>

## Binks MODEL 7™ SPRAY GUN GENERAL MAINTENANCE

### SPRAY GUN

1. Immerse only the front end of the gun until solvent just covers the fluid connection.
2. Use a bristle brush and solvent to wash off accumulated paint.
3. Do not submerge the entire spray gun in solvent because:
  - a. the lubricant in the leather packings will dissolve and the packings will dry out.
  - b. the lubricant at wear surfaces will dissolve causing harder operation and faster wear.
  - c. residue from dirty solvent may clog the narrow air passages in the gun.
4. Wipe down the outside of the gun with solvent-dampened rag.
5. Lubricate gun daily. Use a light machine oil on:
  - a. fluid needle packing.
  - b. air valve packing.
  - c. side port control packing.
  - d. trigger pivot point.
 Coat the fluid control spring with vaseline.

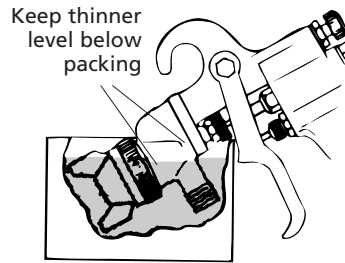

### AIR NOZZLE, FLUID NOZZLE, NEEDLE

1. All nozzles and needles are precision made. They should be handled with care.
2. Do not make any alterations in the gun. To do so could cause finishing difficulties.
3. To clean nozzles, soak them in solvent to dissolve any dried material, then blow them clean with air.
4. Do not probe any of the holes in the nozzles with metal instruments. If probing is necessary, use only a tool that is softer than brass.

### ⚠ CAUTION

Never use lubricants containing silicone since these lubricants can cause finish defects.

### NOTE

All parts on a spray gun should be screwed in hand tight at first; this will avoid the possibility of cross threading the parts. If the parts can not be turned by hand easily, make sure you have the correct parts, unscrew, realign, and try again. NEVER use undue force in mating parts.

## POINTERS ON CLEANING

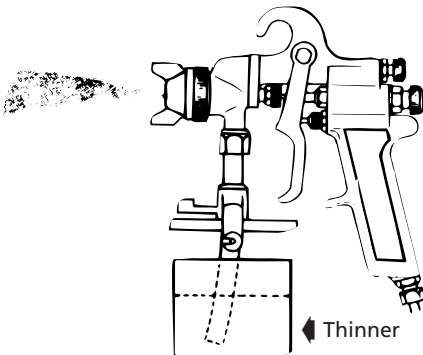

### When Used With Siphon Cup

A compatible thinner or solvent should be siphoned through gun by inserting tube in open container of that liquid. Trigger gun repeatedly to flush passageway thoroughly and to clean tip of needle.

When local codes prohibit spraying of thinner or solvent, use a gun washer to clean spray guns.

### When Used With Pressure Tank

Shut off air supply to tank and release pressure on tank. Open vent and loosen air nozzle. Hold a piece of cloth over the air nozzle and squeeze trigger. Air will back up through fluid nozzle, and force fluid out of hose into tank. Next, put enough thinner into tank to wash hose and gun thoroughly. Spray thinner through the gun until it is clean. Attach fluid hose to air line and blow it out thoroughly to remove all traces of materials and to dry it.

Binks MODEL 7™ SPRAY GUN

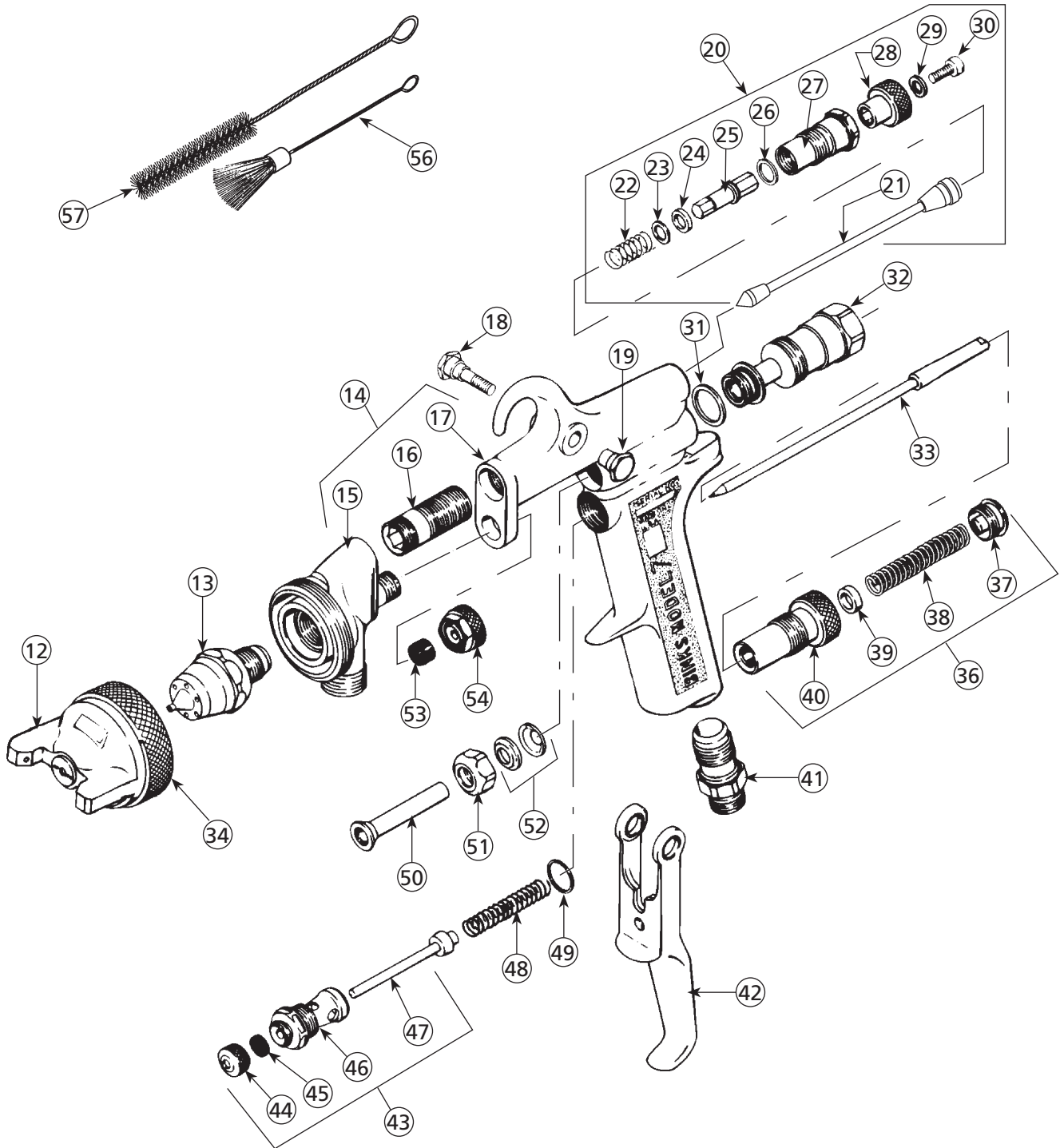

# PARTS LIST

When ordering, please specify Part No.

ITEM NO.	PART NO.	DESCRIPTION	QTY.	ITEM NO.	PART NO.	DESCRIPTION	QTY.
12	*	AIR NOZZLE.....	1	36	54-724★	FLUID CONTROL ASSEMBLY.....	1
13	*	FLUID NOZZLE.....	1	37	54-725•	SCREW.....	1
14	54-706•	HEAD AND BODY ASSEMBLY.....	1	38	54-728-5■□•	SPRING (Kit of 5).....	1
15	54-707★	HEAD.....	1	39	54-727•	RING.....	1
16	54-710★	SCREW.....	1	40	54-726•	BODY.....	1
17	54-711•	BODY.....	1	41	54-768★	CONNECTION.....	1
18	54-759★	SCREW Trigger.....	1	42	54-753★	TRIGGER.....	1
19	54-760★	STUD Trigger.....	1	43	54-1341	AIR VALVE ASSEMBLY.....	1
20	54-729★	SIDE PORT CONTROL ASSEMBLY .	1	44	54-1340	NUT.....	1
21	54-730★	STEM.....	1	45	54-747-5■□	PACKING (Kit of 5).....	1
22	54-736■•	SPRING.....	1	46	54-751★	BODY.....	1
23	54-737★•	WASHER.....	1	47	54-744■★	STEM.....	1
24	54-738-5■□	PACKING (Kit of 5).....	1	48	54-750-5■□•	SPRING (Kit of 5).....	1
25	54-735★	SPINDLE.....	1	49	54-749-5■□	GASKET (Kit of 5).....	1
26	54-739■★	GASKET.....	1	50	54-718★	SLEEVE.....	1
27	54-734★	HOUSING.....	1	51	54-721★	RETAINER.....	1
28	54-740★	KNOB.....	1	52	54-722-5■□	WIPER (Kit of 5).....	2
29	54-742•	WASHER.....	1	53	2-28-5■□	PACKING (Kit of 5).....	1
30	—	SCREW.....	1	54	54-765★	NUT.....	1
31	54-723-5■□	GASKET (Kit of 5).....	1	55	73-165♦	WRENCH Gunhead (Optional).....	1
32	54-717★	HOUSING.....	1	56	OMX-88	BRUSH.....	1
33	**	NEEDLE VALVE.....	1	57	82-469	BRUSH.....	1
34	†	RING.....	1				

- \* When ordering, please specify number stamped on nozzle.
- \*\* When ordering, please specify number stamped on needle stem.
- † Furnished with nozzle. See Nozzle Chart.
- Available in Repair Kit 6-188. Please order separately.
- Items **NOT** available separately.
- ♦ Optional. Please order separately.
- Available only as a quantity pack.
- ★ Available from Binks distributors only.
- 54-839 Heavy Duty Spring (Optional).

## NOZZLE AND NEEDLE SELECTION CHART

TYPE OF FLUID VISCOSITY TO BE SPRAYED	FLUID x AIR NOZZLES	NOZZLE TYPE ††	CFM AT			MAX. PATTERN AT 8"	FLUID♦ NEEDLE	AIR NOZZLE RETAINING RING
			30 PSI	50 PSI	70 PSI			
<b>THIN</b>	36SS x 36SD	SE	7.8	11.5	—	10.0"	36	**
Sealers, Lacquers, Primers, Stains, Zinc Chromates, Lubricants								
<b>MEDIUM</b>	36SS x 36SD 36SS x 36SK	SE SE	7.8 11.5	11.5 15.7	— 20.2	10.0" 13.0"	36 36	** **
Lacquers, Enamels, Varnishes, Shellacs, Primers, Epoxies, Urethanes, Lubricants								
<b>MEDIUM HEAVY</b>	38SS x 38PM	PE	9.3	14.9	20.0	10.0"	38	**
House Paint, Multicolors, Wrinkles								

- PE Pressure feed, external mix. SE Siphon feed, external mix.
- \* Not furnished with nozzle. Please order separately.
- \*\* Furnished with nozzle.
- ♦ All needles are stainless steel.

<b>FLUID NOZZLE</b>	36SS	38SS
<b>ORIFICE SIZE</b>	.070	.086

6100-1808-9	36SS x 36SD
6100-1809-2	36SS x 36SK
6100-2111-5	38SS x 38PM

**AIR SUPPLY**

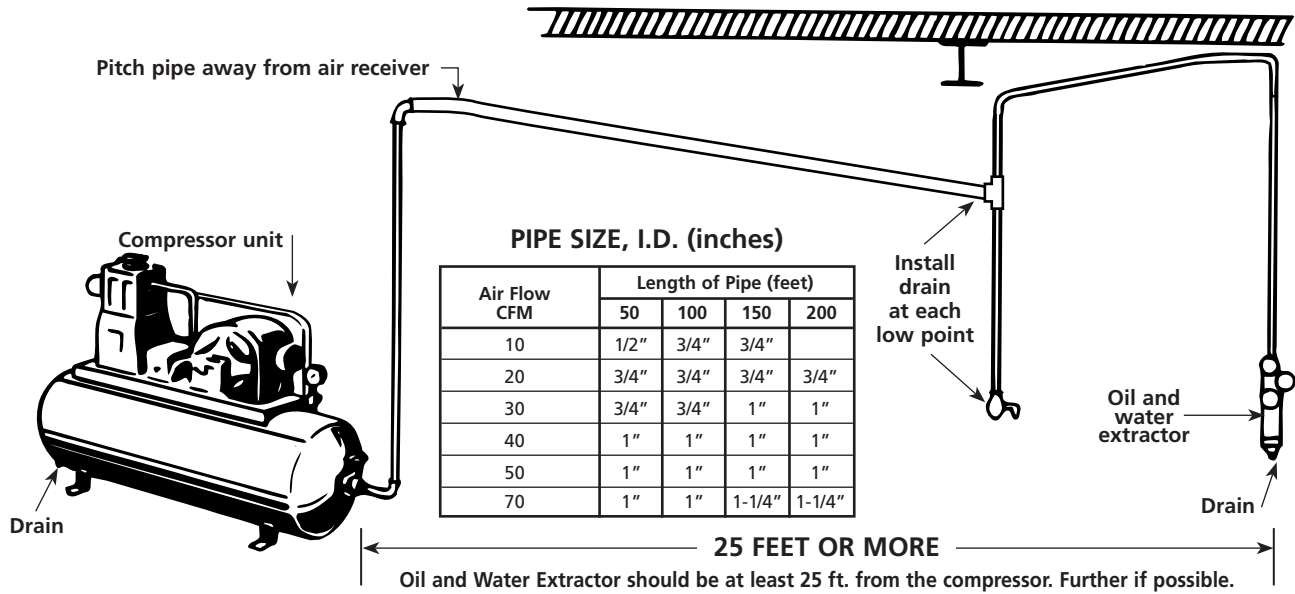

**The Clean Air™ filter should not be mounted on or near the air compressor.**

The temperature of air is greatly increased during compression. As the air cools down to room temperature, in the air line, on its way to the spray gun, the moisture contained in it condenses. Thus, for maximum effectiveness, the oil and water extractor should be mounted at some point in the air supply system where the temperature of the compressed air in the line is likely to be lowest.

**Air lines must be properly drained.**

Pitch all air lines away from the compressor so that condensed moisture can be drained off. Each low point in an air line acts as a water trap. Such points should be fitted with an easily accessible drain. See diagram above.

**AIR PRESSURE**

**Air pressure at the gun is important.**

Atomizing pressure must be set to allow for the drop in air pressure between the regulator and the spray gun.



**Only 44 PSI**

25 feet of 1/4" I.D. hose causes a drop of 16 PSI between the air supply and the gun.



**Only 55 PSI**

25 feet of 5/16" I.D. hose has a drop of only 5 PSI. For this reason we recommend the use of 5/16" hose.

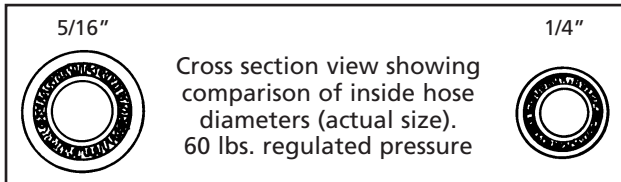

**A DeVilbiss Clean Air™ filter is important.**

A Clean Air™ filter serves a double purpose. It eliminates blistering and spotting by keeping air free from oil and water... and its precision air regulator makes possible perfect air pressure control at the gun.

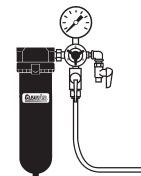

The best spray gun in the world will not operate efficiently without a good compressor and a Clean Air™ filter. Model HFRL-508 is recommended.

If you are attempting to get a fine finish without the use of a Clean Air™ filter you will not succeed.



---

**NOTES**

**NOTES**

---

**NOTES**

## WARRANTY POLICY

Binks products are covered by Carlisle Fluid Technologies one year materials and workmanship limited warranty. The use of any parts or accessories, from a source other than Carlisle Fluid Technologies, will void all warranties. For specific warranty information please contact the closest Carlisle Fluid Technologies location listed below.

Carlisle Fluid Technologies reserves the right to modify equipment specifications without prior notice. DeVilbiss®, Ransburg®, MS®, BGK®, and Binks® are registered trademarks of Carlisle Fluid Technologies, Inc. ©2016 Carlisle Fluid Technologies, Inc. All rights reserved.



Binks is part of Carlisle Fluid Technologies, a global leader in innovative finishing technologies. For technical assistance or to locate an authorized distributor, contact one of our international sales and customer support locations.

### USA/Canada

info@carlisleleft.com  
Tel: 1-888-992-4657  
Fax: 1-888-246-5732

### Mexico

ventas@carlisleleft.com.mx  
Tel: 011 52 55 5321 2300  
Fax: 011 52 55 5310 4790

### Brazil

vendas@carlisleleft.com.br  
Tel: +55 11 5641 2776  
Fax: 55 11 5641 1256

### United Kingdom

info@carlisleleft.eu  
Tel: +44 (0)1202 571 111  
Fax: +44 (0)1202 573 488

### France

info@carlisleleft.eu  
Tel: +33(0)475 75 27 00  
Fax: +33(0)475 75 27 59

### Germany

info@carlisleleft.eu  
Tel: +49 (0) 6074 403 1  
Fax: +49 (0) 6074 403 281

### China

mkt@carlisleleft.com.cn  
Tel: +8621-3373 0108  
Fax: +8621-3373 0308

### Japan

overseas-sales@carlisleleft.co.jp  
Tel: 081 45 785 6421  
Fax: 081 45 785 6517

### Australia

sales@carlisleleft.com.au  
Tel: +61 (0) 2 8525 7555  
Fax: +61 (0) 2 8525 7575

For the latest information about our products, visit [www.carlisleleft.com](http://www.carlisleleft.com).

# CET

DISTRIBUTED BY COATING EQUIPMENT TECHNOLOGY, INC.

