



MODEL 30 AUTOMATIC GLASS BEAD DISPENSING GUN
6279-0000-1 MODEL 30
6279-0000-5 MODEL 30 (BIG BORE)

The Model 30 Glass Bead Dispensing Gun delivers glass beads at the rate of up to 20 lbs. per minute. (A pressure tank with follower plate and bottom outlet is recommended for supply of glass beads to the gun.) Air for atomization is not required.

"On-off" of the gun is provided by the air cylinder. It is located at the rear of the gun body. The minimum recommended air pressure to the cylinder is 50 PSIG.



CAUTION

The gun should never be operated without having the guard (28) installed. All threads, including the hose connections, should be clean of beads before mating. The needle (15) should always be kept clean.

INSTALLATION

Mount the Model 30 gun on a 1/2" diameter steel rod. (Not furnished with gun. Please order separately, Model 54-380.) The rod should have a flat area to receive the mounting screw (19) for locking the gun to the rod. Attach the air hose to the 1/4" NPS(m) nipple (21) and attach the glass bead supply hose to the 3/4" NPS(m) inlet on the gun head (16).

NOTE

Be sure mating threads are clean of beads.

Depending on the delivery required, select the appropriate nozzle (orifice) insert (13) and install into the deflection nozzle (12). Install this assembly (14) into the gun and fasten securely with retainer ring (10) and o-ring (11).

NOTE

Be sure mating threads are clean of beads.

DISASSEMBLY INSTRUCTIONS

Read entire disassembly instructions before attempting repairs. Do only that which is required to repair a specific trouble. Complete disassembly may not be required.

1. Remove the screw (27) and guard (28).
2. Remove cap (3), control screw (1) and lock-nut (2). Remove springs (4) and (5).
3. Remove nozzle assembly (14) by unscrewing retainer ring (10).
4. Using a 11/16" socket, hold piston rod (6) and loosen nut (22) with a 7/16" wrench.
5. Unscrew needle (15) from piston rod (6) and nut (22). Remove take-up screw (23) from gun head (16). Since o-ring (24) and take-up screw (23) offer resistance to removal from needle (15), unscrew take-up screw (23) from needle (15), rather than pulling forcefully. Remove needle (15) from front of gun head (16).
6. Remove wiper (25) and retainer (26) from gun head (16).
7. Remove piston rod (6) and piston (8) by feeding air into the air inlet (21) at 5-10 PSIG.
8. Remove screw (17) and lockwasher (18) and separate gun body (20) from gun head (16).

ASSEMBLY INSTRUCTIONS

Before assembling gun, clean off all mating surfaces and remove any beads clinging to them.

1. Attach gun head (16) to gun body (20) with screw (17) and lockwasher (18).
2. Insert needle (15) through front of gun head (16). Check wiper (25) and retainer (26) and replace if worn or damaged. Install retainer (26) and wiper (25) through rear of gun head (16) onto needle (15).
3. Check o-ring (24) and replace if worn or damaged. Seat o-ring (24) correctly into take-up screw (23). Screw take-up screw o-ring assembly (23, 24) over needle threads (15) and into gun head (16) to finger tightness and tighten additionally 1/8 to 1/4 turn by wrench.
4. Screw nut (22) onto needle (15).
5. Check u-cup (9) and two o-rings (7) and replace if worn or damaged. Seat two o-rings (7) correctly onto piston rod (6) and seat u-cup (9) correctly onto piston (8). Insert piston rod (6) through piston (8) and insert piston rod/piston assembly (6, 8) into gun body (20).
6. Push piston rod (6) all the way into gun body (20) and hold it there with 11/16" socket wrench. Screw needle (15) deep into piston rod (6) while, at same time, turning nut (22), as required, to avoid "lockup".
7. Hold gun with nozzle end up. Insert nozzle assembly (14). Do not install retainer ring (10).
8. Unscrew piston rod (6) with socket wrench, while pushing on piston rod (6) and allow needle (15) to "lift" nozzle assembly (14) 3/32" off gun head (16).
9. While preventing needle (15) from turning, and while pushing on piston rod (6), screw nut (22) forward so as to lock against take-up screw (23). Tighten nut (22) securely with 7/16" wrench.
10. Install spring (4) and cap (3).
11. Install spring (5), lock-nut (2) and control screw (1).
12. Select appropriate nozzle insert (13) and insert into deflection nozzle (12). Insert nozzle assembly (14) into gun head (16).
13. Check o-ring (11) and replace if worn or damaged. Seat o-ring (11) correctly onto gun head (16).
14. Screw retainer ring (10) onto gun head (16) and make hand tight.
15. Attach guard (28) with screw (27) and nut (29).

In this part sheet, the words **WARNING**, **CAUTION** and **NOTE** are used to emphasize important safety information as follows:

WARNING

Hazards or unsafe practices which could result in severe personal injury, death or substantial property damage.

CAUTION

Hazards or unsafe practices which could result in minor personal injury, product or property damage.

NOTE

Important installation, operation or maintenance information.

WARNING

Read the following warnings before using this equipment.



READ THE MANUAL

Before operating finishing equipment, read and understand all safety, operation and maintenance information provided in the operation manual.



OPERATOR TRAINING

All personnel must be trained before operating finishing equipment.



EQUIPMENT MISUSE HAZARD

Equipment misuse can cause the equipment to rupture, malfunction, or start unexpectedly and result in serious injury.



LOCK OUT / TAG-OUT

Failure to de-energize, disconnect, lock out and tag-out all power sources before performing equipment maintenance could cause serious injury or death.



AUTOMATIC EQUIPMENT

Automatic equipment may start suddenly without warning.



PRESSURE RELIEF PROCEDURE

Always follow the pressure relief procedure in the equipment instruction manual.



KEEP EQUIPMENT GUARDS IN PLACE

Do not operate the equipment if the safety devices have been removed.



KNOW WHERE AND HOW TO SHUT OFF THE EQUIPMENT IN CASE OF AN EMERGENCY



WEAR SAFETY GLASSES

Failure to wear safety glasses with side shields could result in serious eye injury or blindness.



INSPECT THE EQUIPMENT DAILY

Inspect the equipment for worn or broken parts on a daily basis. Do not operate the equipment if you are uncertain about its condition.



NEVER MODIFY THE EQUIPMENT

Do not modify the equipment unless the manufacturer provides written approval.



NOISE HAZARD

You may be injured by loud noise. Hearing protection may be required when using this equipment.

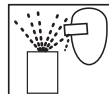

PROJECTILE HAZARD

You may be injured by venting liquids or gases that are released under pressure, or flying debris.



PINCH POINT HAZARD

Moving parts can crush and cut. Pinch points are basically any areas where there are moving parts.



STATIC CHARGE

Fluid may develop a static charge that must be dissipated through proper grounding of the equipment, objects to be sprayed and all other electrically conductive objects in the dispensing area. Improper grounding or sparks can cause a hazardous condition and result in fire, explosion or electric shock and other serious injury.



WEAR RESPIRATOR

Toxic fumes can cause serious injury or death if inhaled. Wear a respirator as recommended by the fluid and solvent manufacturer's Safety Data Sheet.



TOXIC FLUID & FUMES

Hazardous fluid or toxic fumes can cause serious injury or death if splashed in the eyes or on the skin, inhaled, injected or swallowed. LEARN and KNOW the specific hazards or the fluids you are using.



FIRE AND EXPLOSION HAZARD

Improper equipment grounding, poor ventilation, open flame or sparks can cause a hazardous condition and result in fire or explosion and serious injury.



MEDICAL ALERT

Any injury caused by high pressure liquid can be serious. If you are injured or even suspect an injury:

- Go to an emergency room immediately.
- Tell the doctor you suspect an injection injury.
- Show the doctor this medical information or the medical alert card provided with your airless spray equipment.
- Tell the doctor what kind of fluid you were spraying or dispensing.



GET IMMEDIATE MEDICAL ATTENTION

To prevent contact with the fluid, please note the following:

- Never point the gun/valve at anyone or any part of the body.
- Never put hand or fingers over the spray tip.
- Never attempt to stop or deflect fluid leaks with your hand, body, glove or rag.
- Always have the tip guard on the spray gun before spraying.
- Always ensure that the gun trigger safety operates before spraying.



PROP 65 WARNING

WARNING: This product contains chemicals known to the State of California to cause cancer and birth defects or other reproductive harm.

IT IS THE RESPONSIBILITY OF THE EMPLOYER TO PROVIDE THIS INFORMATION TO THE OPERATOR OF THE EQUIPMENT. FOR FURTHER SAFETY INFORMATION REGARDING THIS EQUIPMENT, SEE THE GENERAL EQUIPMENT SAFETY BOOKLET (77-5300).

Binks Model 30 AUTOMATIC GLASS BEAD DISPENSING GUN

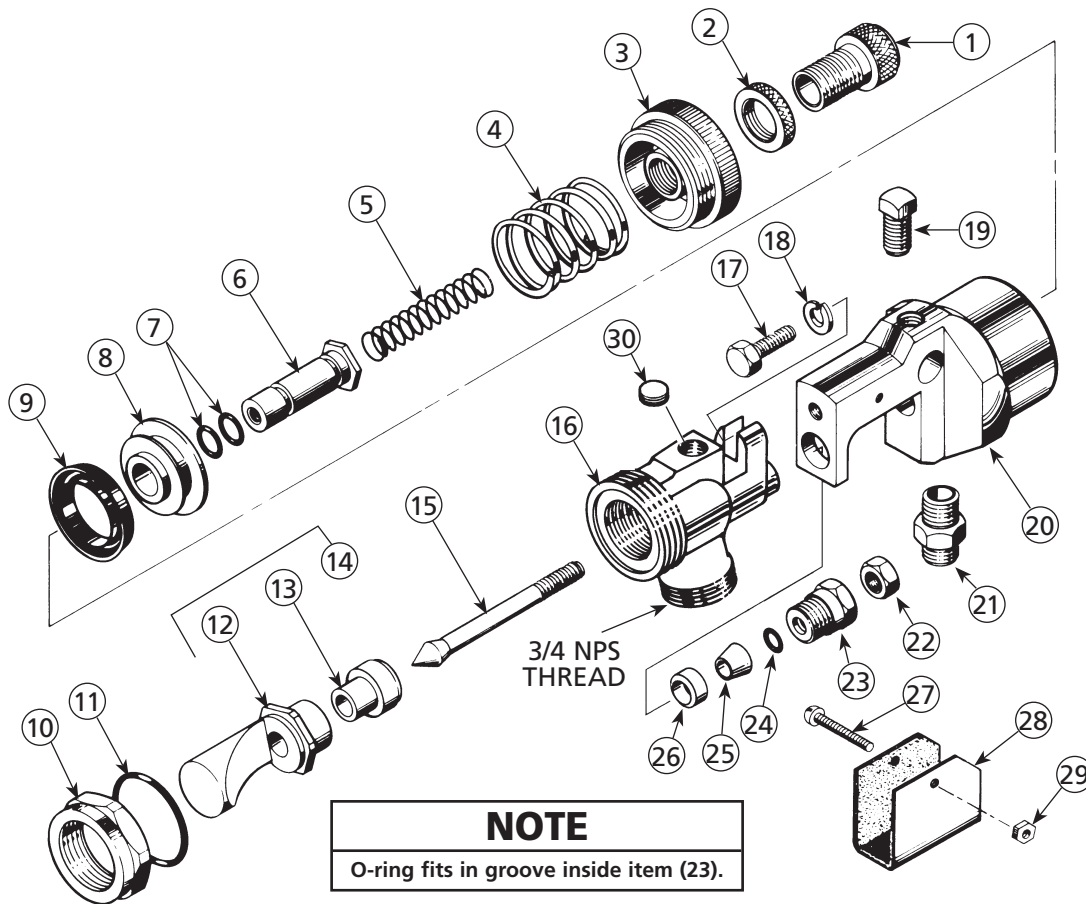

NOTE

O-ring fits in groove inside item (23).

PARTS LIST

When ordering, please specify Part No.

ITEM NO.	PART NO.	DESCRIPTION	QTY.	ITEM NO.	PART NO.	DESCRIPTION	QTY.
1	54-1195	CONTROL SCREW.....	1	16	54-1208	GUN HEAD.....	1
2	54-323	CONTROL SCREW LOCKNUT.....	1	17	20-702-1	SCREW, HEX HEAD.....	1
3	54-1196	CAP.....	1			1/4"-20 x 7/8" Long.....	1
4	54-236	SPRING.....	1	18	20-1041-1	LOCKWASHER.....	1
5	54-1648▲	SPRING.....	1	19	54-335	MOUNTING SCREW.....	1
6	54-1197	PISTON ROD.....	1	20	54-1194	GUN BODY.....	1
7	20-2369▲	O-RING.....	2	21	57-13-1	D.M. NIPPLE 1/4" NPS x 1/4" NPT.....	1
8	102-2059	PISTON.....	1	22	20-301-1	HEX NUT 1/4"-20.....	1
9	20-3723▲	U-CUP.....	1	23	54-1198	SCREW.....	1
10	52-1635	RETAINER RING.....	1	24	20-3620-5▲	O-RING.....	1
11	20-3829▲	O-RING.....	1	25	54-3114▲*	WIPER.....	1
12	45-102■	DEFLECTION NOZZLE .344" Dia.....	1	26	54-3113▲*	RETAINER.....	1
13	45-103■	NOZZLE INSERT 7/32" Dia.....	1	27	20-4827	SCREW, ROUND HEAD.....	1
13	45-104■	NOZZLE INSERT 1/4" Dia.....	1			6-32 x 1 1/4" Long.....	1
13	45-105■	NOZZLE INSERT 9/32" Dia.....	1	28	54-1199	GUARD.....	1
13	45-106■	NOZZLE INSERT 11/32" Dia.....	1	29	20-412-1	NUT 6-32.....	1
14	45-101	DEFLECTION NOZZLE and INSERT ASSEMBLY.....	1	30	20-2287-1	PIPE PLUG 1/8" NPT SOC Head.....	1
15	47-458	NEEDLE.....	1	—	6-1287	OPTIONAL: 1/2" BIG BORE KIT.....	1

▲ Also available in 6-271 Repair Kit. Please order separately.

■ Part of 45-101 Assembly.

* Also available in 54-3116 Wiper Kit. Please order separately.

Ref. Only: To convert to 1/2" nozzle, use 6-1287 Kit.

WARRANTY POLICY

This product is covered by Carlisle Fluid Technologies' materials and workmanship limited warranty. The use of any parts or accessories, from a source other than Carlisle Fluid Technologies, will void all warranties. Failure to reasonably follow any maintenance guidance provided may invalidate any warranty.

For specific warranty information please contact Carlisle Fluid Technologies.

Carlisle Fluid Technologies is a global leader in innovative finishing technologies. Carlisle Fluid Technologies reserves the right to modify equipment specifications without prior notice.

DeVilbiss®, Ransburg®, ms®, BGK®, and Binks®
are registered trademarks of Carlisle Fluid Technologies, Inc.

©2018 Carlisle Fluid Technologies, Inc.
All rights reserved.

For technical assistance or to locate an authorized distributor, contact one of our international sales and customer support locations.

Region	Industrial / Automotive	Automotive Refinishing
Americas	Tel: 1-800-992-4657 Fax: 1-888-246-5732	Tel: 1-800-445-3988 Fax: 1-800-445-6643
Europe, Africa, Middle East, India	Tel: +44 (0)1202 571 111 Fax: +44 (0)1202 573 488	
China	Tel: +8621-3373 0108 Fax: +8621-3373 0308	
Japan	Tel: +81 45 785 6421 Fax: +81 45 785 6517	
Australia	Tel: +61 (0) 2 8525 7555 Fax: +61 (0) 2 8525 7575	



DISTRIBUTED BY COATING EQUIPMENT TECHNOLOGY, INC

For the latest information about our products, visit www.carlisleleft.com