



Binks SV50 HVLP GRAVITY FEED SPRAY GUN & TOUCHUP GUN

ATTENTION!

READ BEFORE ATTACHING THE AIR HOSE

HVLP AIR SUPPLY REQUIREMENTS

FULL SIZE GUN: 30 PSI inlet pressure provides 10 PSI at the air cap. Consumes 12 CFM.

TOUCHUP GUN: 30 PSI inlet pressure provides 10 PSI at the air cap. Consumes 8 CFM.

NOTE: USE 5/16" OR LARGER I.D. AIR HOSES

SPECIFICATIONS

Max. Air Pressure:	100psi
For HVLP Compliance:	30 psi inlet pressure delivers 10 psi air cap pressure
Gun Body:	Cast Aluminum
Fluid Path:	Aluminum
Fluid Nozzle:	Stainless Steel
Fluid Needle:	Stainless Steel
Air Inlet Size:	1/4" NPS(M)



OPERATION AND MAINTENANCE INSTRUCTIONS

Your new SV50 Gravity Feed Spray Gun and Gravity Feed Touchup Gun are exceptionally rugged in construction and built to stand up under hard, continuous use. However, like any other fine precision instruments, their most efficient operation depends on a knowledge of their construction, operation, and maintenance. Properly handled and cared for, they will produce beautiful, uniform finishing results long after other spray guns have worn out.

⚠ WARNING

Servicing the gun while pressurized could result in components or material exiting the gun at high velocity, possibly resulting in personal injury or damage to the spray gun. Before removing any components from the spray gun, shut off air pressure and drain material from the paint cup.

SET-UP FOR SPRAYING (Figure 1) CONNECTING GUN TO AIR HOSE

Air should be supplied by a suitable length of 5/16" diameter air hose fitted with a 1/4 NPS(f) connection to the base of the gun handle. For hose lengths over 50', use 3/8" hose.

CONNECTING GRAVITY FEED CUP TO GUN

Screw the cup into the spray gun fluid inlet. Fill the cup with filtered paint.

If desired, attach air adjusting valve with gauge and/or quick disconnect to air inlet, then attach hose. Spray test and adjust air pressure, fan size, and fluid flow as required. Recommended spray distance is 6-8 inches.

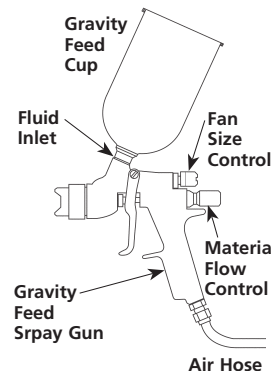

⚠ WARNING

A failure resulting in injury or damage may be caused by pressure beyond top of scale, excessive vibration or pressure pulsation, excessive instrument temperature, corrosion of the pressure containing parts or other misuse of the air adjusting valve with gauge.

Figure 1

In this part sheet, the words **WARNING**, **CAUTION** and **NOTE** are used to emphasize important safety information as follows:

⚠ WARNING
 Hazards or unsafe practices which could result in severe personal injury, death or substantial property damage.

⚠ CAUTION
 Hazards or unsafe practices which could result in minor personal injury, product or property damage.

NOTE
 Important installation, operation or maintenance information.

⚠ WARNING

Read the following warnings before using this equipment.



READ THE MANUAL
 Before operating finishing equipment, read and understand all safety, operation and maintenance information provided in the operation manual.



WEAR SAFETY GLASSES
 Failure to wear safety glasses with side shields could result in serious eye injury or blindness.

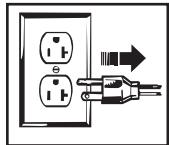

DE-ENERGIZE, DISCONNECT AND LOCK OUT ALL POWER SOURCES DURING MAINTENANCE
 Failure to De-energize, disconnect and lock out all power supplies before performing equipment maintenance could cause serious injury or death.



OPERATOR TRAINING
 All personnel must be trained before operating finishing equipment.



EQUIPMENT MISUSE HAZARD
 Equipment misuse can cause the equipment to rupture, malfunction, or start unexpectedly and result in serious injury.



KEEP EQUIPMENT GUARDS IN PLACE
 Do not operate the equipment if the safety devices have been removed.

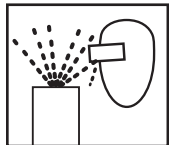

PROJECTILE HAZARD
 You may be injured by venting liquids or gases that are released under pressure, or flying debris.



PINCH POINT HAZARD
 Moving parts can crush and cut. Pinch points are basically any areas where there are moving parts.



AUTOMATIC EQUIPMENT
 Automatic equipment may start suddenly without warning.



INSPECT THE EQUIPMENT DAILY
 Inspect the equipment for worn or broken parts on a daily basis. Do not operate the equipment if you are uncertain about its condition.



NEVER MODIFY THE EQUIPMENT
 Do not modify the equipment unless the manufacturer provides written approval.



KNOW WHERE AND HOW TO SHUT OFF THE EQUIPMENT IN CASE OF AN EMERGENCY



PRESSURE RELIEF PROCEDURE
 Always follow the pressure relief procedure in the equipment instruction manual.



NOISE HAZARD
 You may be injured by loud noise. Hearing protection may be required when using this equipment.



STATIC CHARGE
 Fluid may develop a static charge that must be dissipated through proper grounding of the equipment, objects to be sprayed and all other electrically conductive objects in the dispensing area. Improper grounding or sparks can cause a hazardous condition and result in fire, explosion or electric shock and other serious injury.



FIRE AND EXPLOSION HAZARD
 Never use 1,1,1-trichloroethane, methylene chloride, other halogenated hydrocarbon solvents or fluids containing such solvents in equipment with aluminum wetted parts. Such use could result in a serious chemical reaction, with the possibility of explosion. Consult your fluid suppliers to ensure that the fluids being used are compatible with aluminum parts.



PROP 65 WARNING
 WARNING: This product contains chemicals known to the State of California to cause cancer and birth defects or other reproductive harm.

IT IS THE RESPONSIBILITY OF THE EMPLOYER TO PROVIDE THIS INFORMATION TO THE OPERATOR OF THE EQUIPMENT.

FOR FURTHER SAFETY INFORMATION REGARDING BINKS AND DEVILBISS EQUIPMENT,
 SEE THE GENERAL EQUIPMENT SAFETY BOOKLET (77-5300).

GENERAL SPRAY INSTRUCTIONS

To reduce overspray and obtain maximum efficiency, always spray with the lowest possible fluid/air pressure that produces an acceptable spray pattern.

Excessive atomizing air pressure can increase overspray, reduce transfer efficiency and with some materials, result in poor finish quality from dry spray.

Generally use up to 20 psi air at gun inlet. Unusually heavy, difficult to atomize materials may require up to 30 psi at gun inlet. See *Specifications* on page 1.

SPRAY TECHNIQUE

The first requirement for a good resultant finish is the proper handling of the gun. The gun should be held perpendicular to the surface being covered and moved parallel with it. The stroke should be started before the trigger is pulled and the trigger should be released before the stroke is ended. This gives accurate control of the gun and material.

The distance between gun and surface should be 6 to 8 inches depending on material and atomizing pressure. The material deposited should always be even and wet. Lap each stroke over the preceding stroke to obtain a uniform finish.

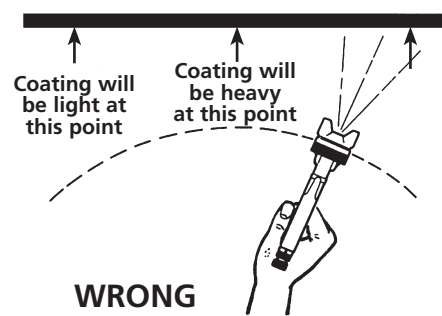
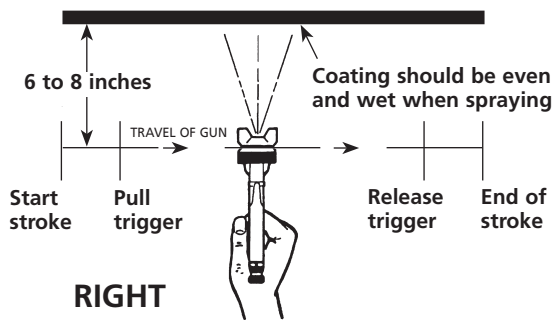

PACKING ADJUSTMENT INSTRUCTIONS

Before using this spray gun, the packing nut should be adjusted as follows:

1. Tighten packing nut until fluid needle starts to bind in the packing.
2. Loosen packing nut just enough so the fluid needle moves freely.

The packing nut is intentionally left loose so the PTFE packing does not take a "set" before the spray gun is used. This allows full utilization of the packing.

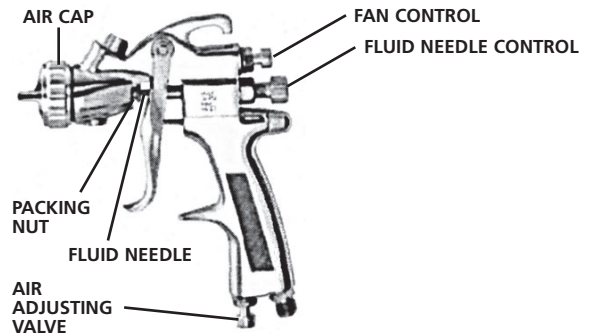

PREVENTIVE MAINTENANCE

SPRAY GUN LUBRICATION

Apply a drop of SSL-10 spray gun lube at trigger bearing stud and the stem of the air valve. The shank of the fluid needle where it enters the packing nut should also be oiled. The fluid needle packing should be kept soft and pliable by periodic lubrication. Make sure the baffle and retaining ring threads are clean and free of foreign matter. Before assembling retaining ring to baffle, clean the threads thoroughly, then add two drops of SSL-10 spray gun lube to threads. The fluid needle spring and air valve spring should be coated with a very light grease, making sure that any excess grease will not clog the air passages. For best results, lubricate the points indicated, daily.

- A. Trigger Points
- B. Packing
- C. Adjusting Valves
- D. Baffle/Air Cap Threads

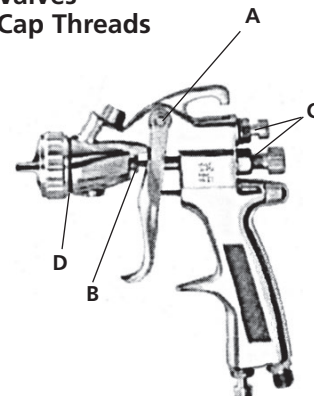

AIR NOZZLE, FLUID NOZZLE, FLUID NEEDLE

NOTE

To reduce overspray and obtain maximum efficiency always spray with the lowest possible atomizing air pressure.

1. All nozzles and needles are precision made. They should be handled with care.
2. Do not make any alterations in the gun. To do so could cause finishing difficulties.
3. To clean nozzles, soak them in solvent to dissolve any dried material, then blow them clean with air.
4. Do not probe any of the holes in the nozzles with metal instruments. If probing is necessary, use only a tool that is softer than brass.

⚠ CAUTION

Never use metal instruments to clean the air or fluid nozzles. These parts are carefully machined and any damage to them will cause faulty spray.

OPERATING THE SV50 GRAVITY FEED SPRAY GUN

CONTROLLING THE MATERIAL FLOW

Correct fluid nozzle size should be selected for proper material flow rate. The material valve control knob may be used to restrict the material needle valve opening and reduce the material flow as necessary.

CONTROLLING THE FAN SPRAY

The fan spray is controlled by means of the spray pattern valve control assembly. Turning this control clockwise until it is closed will give a round spray. Turning it counter-clockwise will widen the spray into a fan shape. The fan spray can be turned anywhere through 360° by positioning the air cap relative to the gun. To affect this, loosen retainer ring, position nozzle, then tighten retainer ring.

TROUBLE SHOOTING

FAULTY SPRAY

A faulty spray is often caused by improper cleaning resulting in dried materials around the material nozzle tip or in the air nozzle. Soak these parts in thinners to soften the dried material and remove with a brush or cloth. If either the air cap or fluid nozzle are damaged, these parts must be replaced before perfect spray can be obtained.

⚠ CAUTION

Never use metal instruments to clean the air or material nozzles. These parts are carefully machined and any damage to them will cause faulty spray.

INTERMITTENT SPRAY

Fluttering spray is caused by one of the following:

1. Insufficient material in cup. Refill the cup.
2. Loose fluid nozzle. Tighten snugly.
3. Cup connection loose or dirt in connection. Correct as necessary.
4. Air vent in gravity cup blocked. Clear obstruction.

SPRAY GUN CLEANING INSTRUCTIONS

In certain states, spraying solvents which contain Volatile Organic Compounds (VOC) into the atmosphere when cleaning a spray gun is now prohibited.

In order to comply with these new air quality laws, Binks recommends one of the following two methods to clean your spray finishing equipment.

1. Spray solvent through the gun into a *closed system*. An enclosed unit or spray gun cleaning station condenses solvent vapors back into liquid form which prevents escape of VOCs into the atmosphere.
2. Place spray gun in a washer type cleaner. This system must totally enclose the spray gun, cups, nozzles and

other parts during washing, rinsing and draining cycles. This type of unit must be able to flush solvent through the gun without releasing any VOC vapors into the atmosphere.

CLEANING GUN AND GRAVITY FEED CUP

Remove the cup cover and drain unused material from cup. Carefully rinse cup with solvent. Place clean solvent into the cup and spray this through the gun until it is clean. Remove and clean the cup if necessary. Blow air through the gun to dry it. (Refer to Service Bulletin SBBI-4-043 for cleaning instructions when using cup liners.)

BINKS SV50 HVLP GRAVITY FEED SPRAY GUN & TOUCHUP GUN

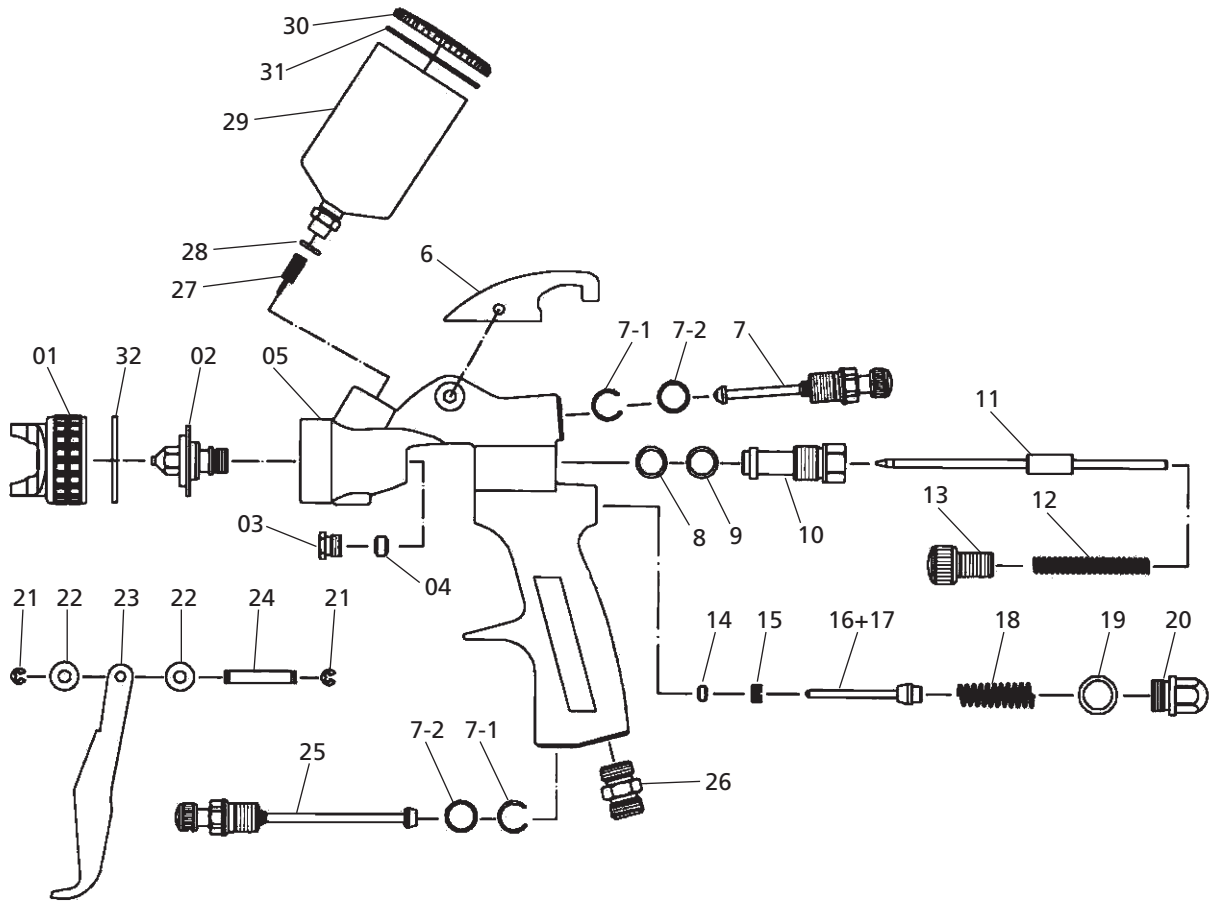

PARTS LIST

REF.	DESCRIPTION	REF.	DESCRIPTION
01	AIR CAP w/Ring	16+17	VALVE STEM COMPLETE
02	FLUID NOZZLE	18	SPRING
03	NUT	19	O-RING
04	GASKET	20	AIR VALVE NUT
05	GUN BODY	21	E-RING (2 pcs.)
06	HOOK	22	WASHER (2 pcs.)
07	FAN CONTROL	23	TRIGGER
7-1	C-CLIP (2 pcs.)	24	TRIGGER STUD
7-2	O-RING (2 pcs.)	25	AIR CONTROL
08	GASKET	26	AIR INLET FITTING
09	O-RING	27	FILTER
10	HOUSING	28	GASKET for Fitting (2 pcs.)
11	PAINT NEEDLE	29	600cc ALUM. CUP 250cc ALUM. CUP
12	SPRING	30	LID
13	KNOB, FLUID CONTROL	31	GASKET for Lid
14	GASKET	32	GASKET for Air Cap
15	SCREW		

NOTES



DISTRIBUTED BY COATING EQUIPMENT TECHNOLOGY, INC

NOTES

WARRANTY

This product is covered by Binks' 1 Year Limited Warranty.

Binks Sales and Service: www.binks.com



U.S.A./Canada Customer Service
195 Internationale Blvd.
Glendale Heights, IL 60139
630-237-5000

Toll Free Customer Service
and Technical Support
800-992-4657

Toll Free Fax
888-246-5732

77-2891R Revisions: (P2) Added Prop 65 warning;
(P3) PTFE reference update; (P8) Updated contact
information.