

# 43P Airless Gun

MODEL: 6370-0000-6

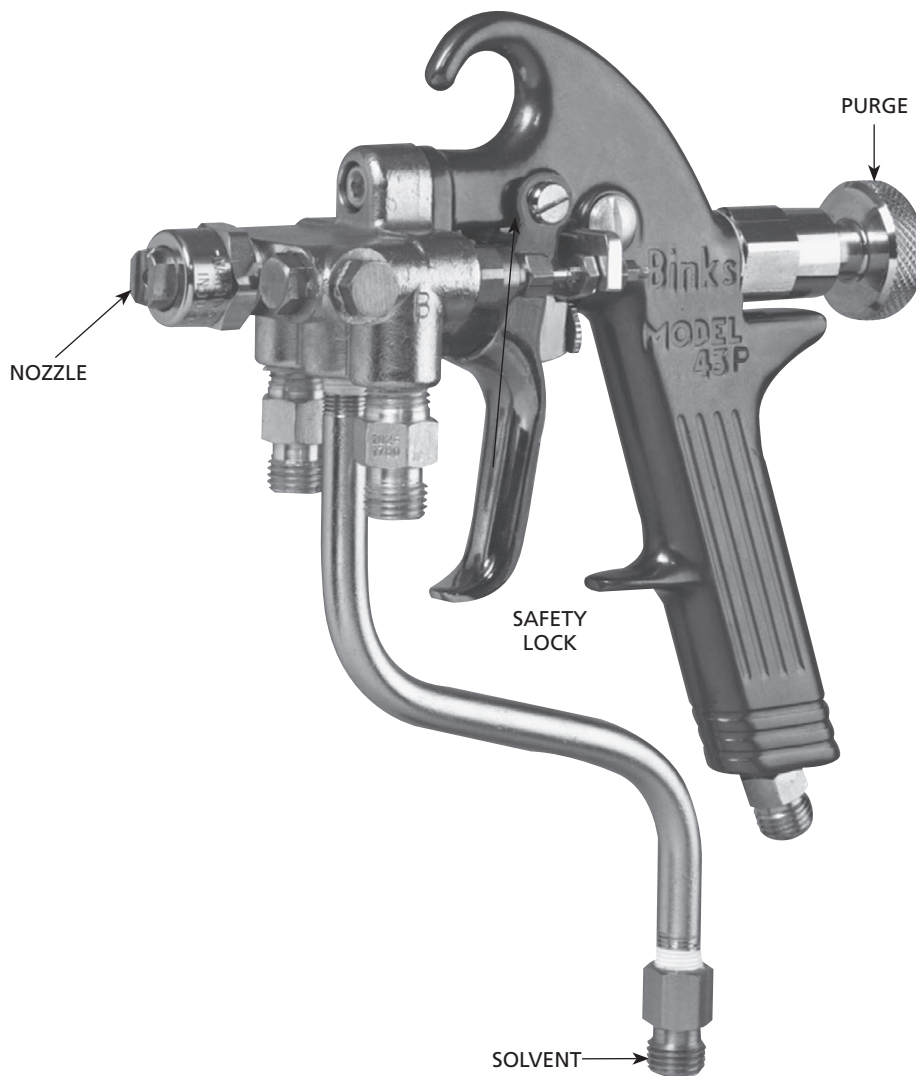

## DESCRIPTION

The Binks Model 43P is a low to medium-volume plural component (spray and/or pour) dispensing device designed specifically for plural component systems. Capacity is up to 20 lbs. spray using a patented static mixing principle.

The 43P, and its companion the 43PA (automatic), uses the opposed internal orifices principle with no moving parts (patented).

Spray patterns are by nozzle selection.

Gun output is dependent upon nozzle and impingement orifices in conjunction with applied fluid pressures. Impingement orifices usually are matched but may be dissimilar to “balance” divergent viscosities and/or ratios.

The 18-8 stainless steel head is designed with cross-drilled ports for ease of maintenance. The ports allow access to remove impacted cured resins. Immersion in solvent will not affect the PTFE seals.

Both resin (1/4 NPS) ports have check valves. The needle valves share common parts (springs, housing, take-up nuts, packings and followers) for simplicity. The resin needles are ball type, the purge is tapered tip.

The rugged forged aluminum gun handle is anodized for corrosion resistance. The trigger’s finger geometry affords comfortable trigger pull and operation.

In this part sheet, the words **WARNING**, **CAUTION** and **NOTE** are used to emphasize important safety information as follows:

**⚠ WARNING**  
 Hazards or unsafe practices which could result in severe personal injury, death or substantial property damage.

**⚠ CAUTION**  
 Hazards or unsafe practices which could result in minor personal injury, product or property damage.

**NOTE**  
 Important installation, operation or maintenance information.

**⚠ WARNING**

Read the following warnings before using this equipment.



**READ THE MANUAL**  
 Before operating finishing equipment, read and understand all safety, operation and maintenance information provided in the operation manual.



**WEAR SAFETY GLASSES**  
 Failure to wear safety glasses with side shields could result in serious eye injury or blindness.



**DE-ENERGIZE, DEPRESSURIZE, DISCONNECT AND LOCK OUT ALL POWER SOURCES DURING MAINTENANCE**  
 Failure to De-energize, disconnect and lock out all power supplies before performing equipment maintenance could cause serious injury or death.



**OPERATOR TRAINING**  
 All personnel must be trained before operating finishing equipment.



**EQUIPMENT MISUSE HAZARD**  
 Equipment misuse can cause the equipment to rupture, malfunction, or start unexpectedly and result in serious injury.

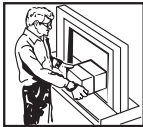

**KEEP EQUIPMENT GUARDS IN PLACE**  
 Do not operate the equipment if the safety devices have been removed.



**HIGH PRESSURE CONSIDERATION**  
 High pressure can cause serious injury. Relieve all pressure before servicing. Spray from the spray gun, hose leaks, or ruptured components can inject fluid into your body and cause extremely serious injury.



**GET IMMEDIATE MEDICAL ATTENTION**  
 To prevent contact with the fluid, please note the following:

- Never point the gun/valve at anyone or any part of the body.
- Never put hand or fingers over the spray tip.
- Never attempt to stop or deflect fluid leaks with your hand, body, glove or rag.
- Always have the tip guard on the spray gun before spraying.
- Always ensure that the gun trigger safety operates before spraying.
- Always lock the gun trigger safety when you stop spraying.



**PRESSURE RELIEF PROCEDURE**  
 Always follow the pressure relief procedure in the equipment instruction manual.



**MEDICAL ALERT**  
 Any injury caused by high pressure liquid can be serious. If you are injured or even suspect an injury:

- Go to an emergency room immediately.
- Tell the doctor you suspect an injection injury.
- Show the doctor this medical information or the medical alert card provided with your airless spray equipment.
- Tell the doctor what kind of fluid you were spraying or dispensing.
- Refer to the Material Safety Data Sheet for specific information.



**TOXIC FLUID & FUMES**  
 Hazardous fluid or toxic fumes can cause serious injury or death if splashed in the eyes or on the skin, inhaled, injected or swallowed. **LEARN** and **KNOW** the specific hazards or the fluids you are using.



**WEAR RESPIRATOR**  
 Toxic fumes can cause serious injury or death if inhaled. Wear a respirator as recommended by the fluid and solvent manufacturer's Material Safety Data Sheet.



**ELECTRIC SHOCK / GROUNDING**  
 Improper grounding or sparks can cause a hazardous condition and result in fire, explosion or electric shock and other serious injury.

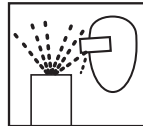

**PROJECTILE HAZARD**  
 You may be injured by venting liquids or gases that are released under pressure, or flying debris.



**FIRE AND EXPLOSION HAZARD**  
 Improper equipment grounding, poor ventilation, open flame or sparks can cause hazardous conditions and result in fire or explosion and serious injury.



**STATIC CHARGE**  
 Fluid may develop a static charge that must be dissipated through proper grounding of the equipment, objects to be sprayed and all other electrically conductive objects in the dispensing area. Improper grounding or sparks can cause a hazardous condition and result in fire, explosion or electric shock and other serious injury.



**PROP 65 WARNING**  
**WARNING:** This product contains chemicals known to the State of California to cause cancer and birth defects or other reproductive harm.

**IT IS THE RESPONSIBILITY OF THE EMPLOYER TO PROVIDE THIS INFORMATION TO THE OPERATOR OF THE EQUIPMENT.**

**FOR FURTHER SAFETY INFORMATION REGARDING BINKS AND DEVILBISS EQUIPMENT, SEE THE GENERAL EQUIPMENT SAFETY BOOKLET (77-5300).**

## Binks MODEL 102-1700 (43P) AIRLESS SPRAY GUN

Your Binks 43P Airless Spray Gun has been thoroughly tested before leaving the factory. No adjustment is required prior to its operation other than installing the nozzle tip.

### 1. Solvent Hook-up

Hook up solvent line and check to insure proper purging. Open purge valve and allow solvent to enter the gun head. Activate valve on-off and observe solvent spray emitting from front of gun. It is important that solvent purge be available in case of incorrect resin-hardener hook-up, reacting fluids, or mixed resins remaining in gun mix chamber.

### 2. Gun Hook-up

Remove Items 1, 2, 3, and 5. Connect material lines to gun. Run system to insure material flows through gun. Shut gun off and allow system to run to stall. Check for leaks at all connections.

### 3. Material Flow Check

*Aim gun into a suitable waste container* or place waste container under front of gun head. Operate formulator and open gun needles until both fluids flow freely from front of gun head. 1:1 systems should appear equal in volume. (Off-ratio systems will visibly be unequal.)

#### NOTE

Purge gun with solvent at end of material flow check.

### 4. Calibration

To check for correct proportioning of two fluids the simplest method is to take two containers of equal capacity and fill them simultaneously.

#### NOTE

When a heated system is used, be sure materials are preheated approximately 1 hour prior to calibrating.

Deviation from volumetric ratio of 1:1 can be attributed to malfunctioning pump(s) or to excessive differences in viscosity of components.

### 5. Shut-Down

When spraying is discontinued for extended periods of time such as lunch, overnight or weekends, the following procedures are recommended:

- A. Remove items 1, 2, 3, and 4 and place in clean solvent. Pack mixing chamber with petroleum jelly.
- B. Leave gun connected to the hoses and formulator and shut-off fluid supply to the gun, but do not

#### NOTE

If you wish to disconnect fluid hoses, you must first shut off main air supply to formulator and gun and then bleed off all fluid material pressure before removing any hoses.

bleed the pressure.

For long shut-down periods, it is necessary to purge ("flush") the system completely (use solvent recommended by the material supplier). Pump sol-

vent through system until all traces of material are removed. Pack gun mixing chamber with petroleum jelly. To exclude ambient moisture and/or foreign matter from hoses and formulator, fill system with an inert fluid such as a plasticiser (DOTP, etc.).

### 6. Gun Ports

The gun head is drilled with bottom material inlet ports (1/4 NPT) and solvent port (1/8 NPT).

### 7. Priming and "Warm-Up"

Heating resins (at the gun head) at start-up can help assure improved mixing. "Warm-up" may also be needed after a down-time of duration that would allow heat loss in hoses to gun.

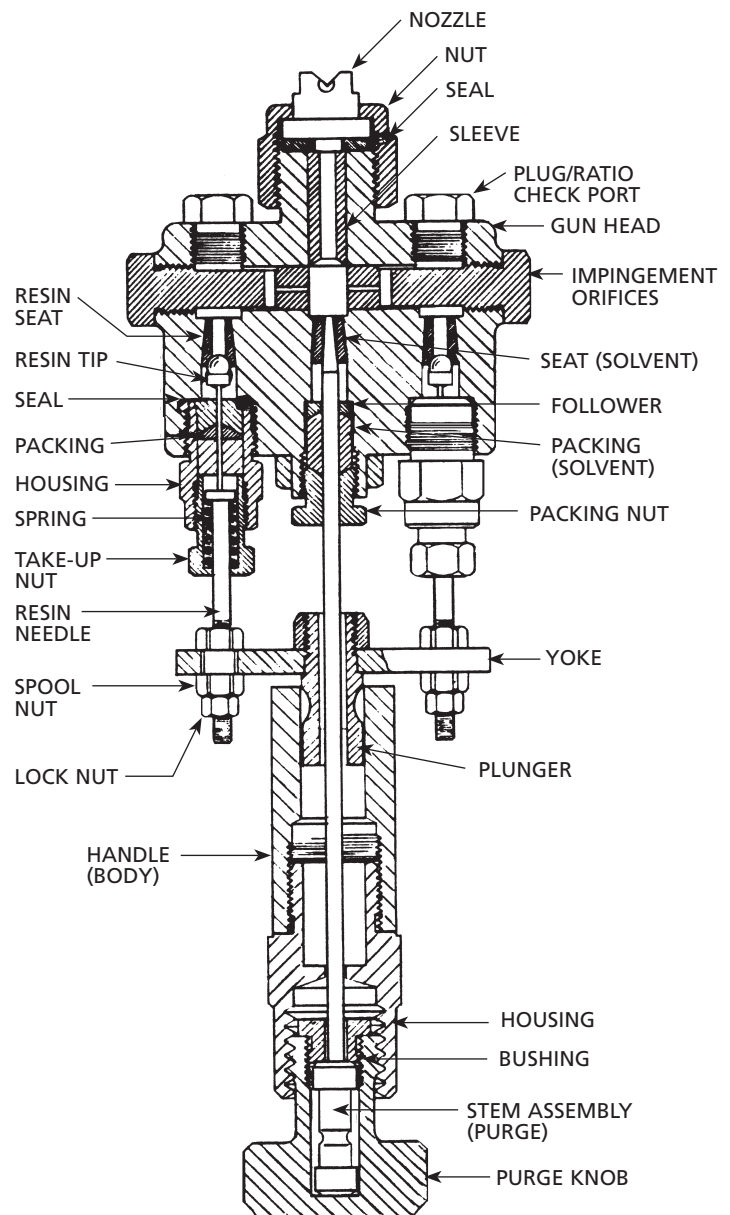

## Binks MODEL 102-1700 (43P) AIRLESS SPRAY GUN

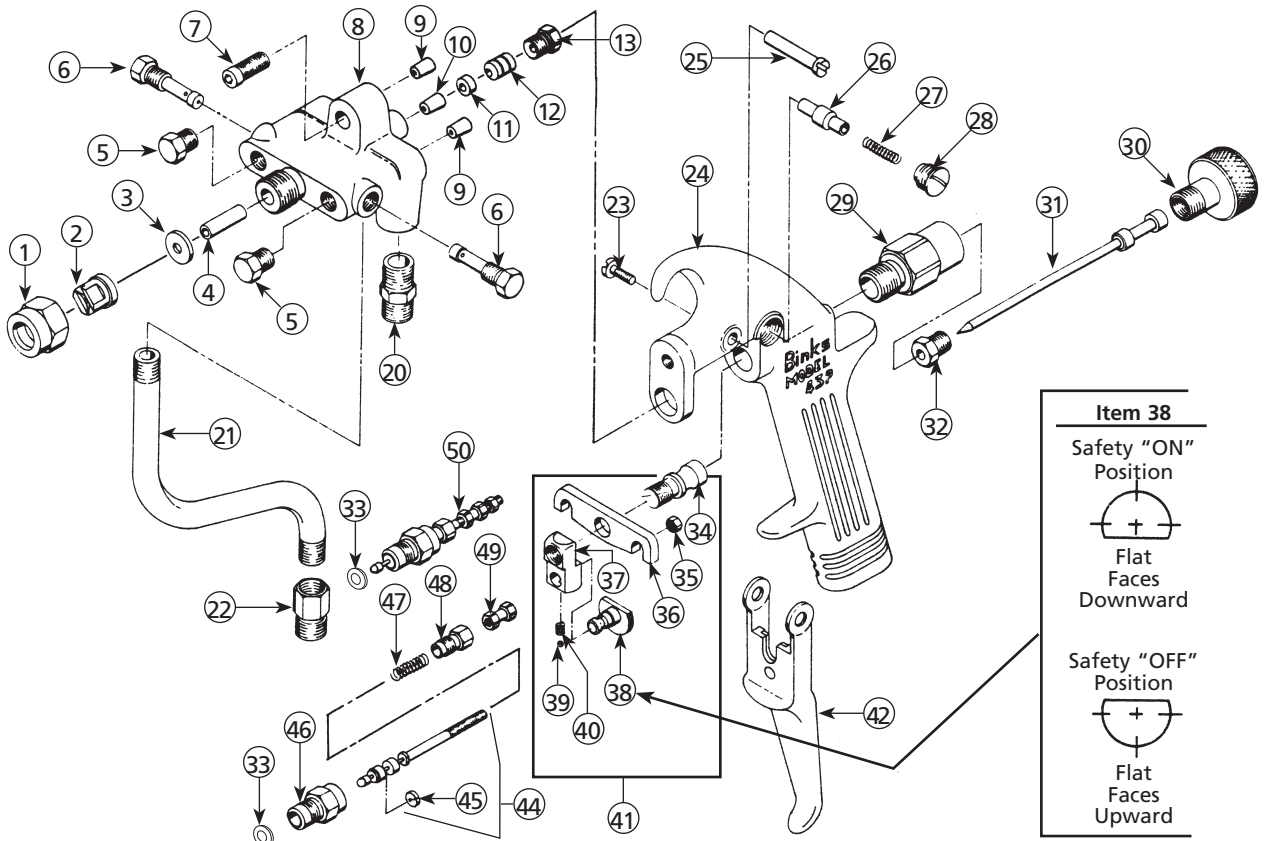

### PARTS LIST

(When ordering, please specify Part No.)

ITEM NO.	PART NO.	DESCRIPTION	QTY.	ITEM NO.	PART NO.	DESCRIPTION	QTY.
1	102-3327	NUT	1	27	54-1637	SPRING	1
2	◆	NOZZLE TIP	1	28	54-1635	SCREW	1
3	54-1439■	GASKET	1	29	102-1705	HOUSING	1
4	102-1738■	INSERT (PTFE)	2	30	102-1703	KNOB	1
5	102-1716	PLUG	2	31	102-1719	STEM	1
6	102-1720*■	ORIFICE .035" Dia.	2	32	102-1704	BUSHING	1
7	20-2195-1	SCREW 1/4-20 x 3/4" Long	1	33	102-3335■	GASKET	2
8	102-1761	HEAD	1	34	102-1749	PLUNGER	1
9	102-1765■	SEAT	2	35	52-487	NUT	2
10	102-1708■	SEAT	1	36	102-2066	YOKE	1
11	102-1717■	FOLLOWER	1	37	102-2067	BLOCK	1
12	2-28■	PACKING	1	38	102-2069	STOP	1
13	54-1969	NUT	1	39	20-3553	BALL	1
15	20-1576	ALLEN WRENCH (Not Shown)	1	40	84-353	SPRING	1
17	OMX-88	BRUSH (Not Shown)	1	41	102-2065	SAFETY LOCK YOKE ASSEMBLY	1
18	82-469	BRUSH (Not Shown)	1	42	102-1709	TRIGGER	1
20	102-1780■	CHECK VALVE ASSEMBLY	2	44	102-1757■	VALVE ASSEMBLY	2
21	102-1743	SOLVENT TUBE	1	45	102-1756	PACKING	2
22	72-727	ADAPTER 1/4 NPS(m) x 1/8 NPT(f)	1	46	102-1725	RETAINER	2
23	82-126	SCREW	1	47	102-1730■	SPRING	2
24	102-1702	BODY	1	48	102-1726	GLAND	2
25	54-1020	TRIGGER STUD	1	49	54-1663	NUT	2
26	54-1641	LOCK	1	50	102-1759	NEEDLE ASSEMBLY	2

- ◆ Not part of gun assembly. Order separately.
- Recommended as replacement items, also available in 106-1078 Spare Parts Kit.
- \* Larger or smaller orifices available for special applications.

#### 106-1078 SPARE PARTS KIT INCLUDES

ITEM	3	4	6	9	10	11	12	20	33	44	47
QTY.	2	2	2	2	1	1	1	2	2	2	2

## MAINTENANCE INSTRUCTIONS

### A. Short Period Shut-down.

1. When stopping operation of the Model 43P gun for short periods exceeding 1/2 hour, remove nut (1), nozzle tip (2), gasket (3), and any washers from gun, and soak them in a clean solvent.
2. Inspect inside of mix chamber (8) and clean thoroughly.
3. Prior to reassembly, blow tip and washers with compressed air and inspect for cleanliness.

### B. Long Period Shut-down.

1. For overnight or longer periods of down-time, it is recommended that items 1, 2, 3, (two) plugs (5) and (two) orifices (6) be removed and placed in a clean solvent.
2. Hold gun over empty container. Rotate knob (30) counter-clockwise to obtain solvent flow to back-flush the mixing chamber in head (8). After flushing, inspect chamber to be sure it is clean.
3. After mixing chamber is clean, pack over openings on head (8) with Vaseline® to prevent crystallization of materials in head.

### C. Needle Valve Assembly, (two) (50).

1. If fluid leaks through gland (48), tighten only enough to stop leak.
2. If leak cannot be stopped:
  - a. Shut off pump and relieve pressure within entire system.
  - b. Remove screw (23), stud (25), and trigger (42).
  - c. Use Allen wrench and remove screw (7). Separate head (8) and body (24).
  - d. Lift off safety lock yoke assembly (41). Use crescent or open-end wrench and remove needle assembly (50).
  - e. Turn out gland (48) until no threads are engaged, thus relieving spring tension on packing (45).
  - f. Remove each of the two retainers (46).
  - g. With knife edge, or sharp tool, pick up split in packing (45) and remove.
  - h. Slip new packing (45) (factory pre-split) over needle wire in needle and packing assembly (43), again exercising care not to damage wire.
  - i. Tighten gland (48) into retainer (46).
  - j. Wrap retainer (46) threads with PTFE tape and insert into head (8). Reinstall needle assembly (50) by reversing above procedures (a) to (c) in Step C.2.
3. The seat (9) is designed for long life and is not usually removed for normal maintenance. If it is damaged and must be removed, repeat procedures (a) to (c), Step C.2. then:
  - a. Remove plug (5).
  - b. Insert 3/16" dia. brass rod, or drift pin, through plug (5) hole and knock out seat (9).
  - c. To replace, insert new seat (9) in the opposite direction from which it was removed. Press and tap into place.

### D. Fluid Inlet Fittings, (two) Items 20.

1. Be sure check valve assembly (20) is clean and moving freely before connecting hoses.
2. When replacing or reinserting (two) check valve assemblies (20), always wrap threads with PTFE tape.

### E. Solvent Flush Valve.

1. Turn off pump and release pressure.
2. To replace packing (12) or seat (10):
  - a. Remove stem (31) by turning out knob (30).
  - b. Remove nut (13).
  - c. Going through front of mix chamber, head (8), use 3/16" dia. brass rod or drift pin to push out packing (12).
  - d. Replace by reversing above procedure.

### NOTE

**Never open knob (30) when trigger is pulled. CAUTION: YOU ARE WORKING WITH TWO HAZARDOUS FACTORS:**

3. a. **High Fluid Pressures**—Be sure the main air or electric supply to outfit is turned "OFF" and liquid pressures relieved from hoses and gun by pulling trigger BEFORE ANY disassembly.
- b. **Small Orifices**—Any dirt in the fluid, or lack of proper maintenance, will cause constant orifice plugging.

### ACCESSORIES

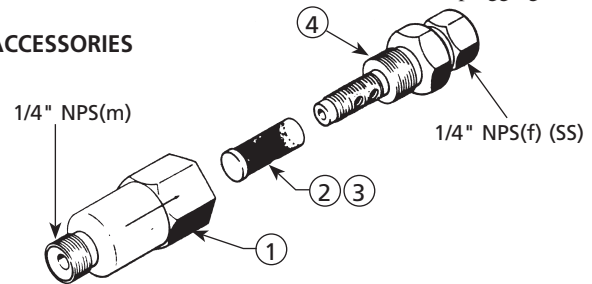

### MODEL 102-2160 FILTER (100 mesh, in-line)

### MODEL 102-2176 FILTER (200 mesh)

#### PARTS LIST

(When ordering, please specify Part No.)

ITEM NO.	PART NO.	DESCRIPTION	QTY.
1	102-2159	SUMP .....	1
2	102-2161	ELEMENT (100 mesh) .....	1
3	102-2177	ELEMENT (200 mesh) .....	1
4	102-2158	STEM ASSEMBLY .....	1



DISTRIBUTED BY COATING EQUIPMENT TECHNOLOGY, INC

NOTES

NOTES

---

## WARRANTY

This product is covered by Binks' 1 Year Limited Warranty.

---

**Binks Sales and Service: [www.binks.com](http://www.binks.com)**

---



U.S.A./Canada Customer Service  
195 Internationale Blvd.  
Glendale Heights, IL 60139  
630-237-5000

Toll Free Customer Service  
and Technical Support  
800-992-4657  
Toll Free Fax  
888-246-5732

**77-1722R-12 Revisions:** PTFE reference update throughout; (P1) Corrected model number; (P2) Added Prop 65 warning; (P8) Updated contact information.