

DEVILBISS AG-360 SERIES

DEVILBISS®

Low Pressure Air Atomization Automatic Spray Gun Range

ATOMIZATION



Professional spray equipment for universal superior performance

Using the acknowledged market leading low Pressure Air Atomization technology from DeVilbiss, the AG-360 series has been developed to provide a blend of finish quality, engineering robustness and superior transfer efficiency.

The AG-360 Auto gun Series from DeVilbiss is available in various gun formats to provide an all-encompassing and universal automatic finishing solution for all applications.

Designed to function in the tough working environment of the modern finishing industry, these guns give you maximum productivity with minimum downtime.

A comprehensive range of CONventional, HVLP and Trans Tech (High Efficiency) Air Caps provide a choice of environmental compliance, transfer efficiency, atomization power and application requirements.

Simple construction and easy maintenance for minimal down-time

Stainless Steel Fluid Passageways for water based & solvent based coating applications

Quick detachable mounting manifolds provide fast and easy maintenance

Compact size and weight for easy positioning and precise alignment

Multiple options and formats to evolve for all application requirements

Independent Fan, Atomizing and Trigger Air - vital for robotic and fully automatic machine applications

AG-361 variants are designed to be cost effective guns with maximum control and serviceability. Available in two models - the **AG-361** for general industrial finishing and the **AG-361E** for the ceramics industry.

The **AG-362** guns are more versatile designs - the **AG-362** for general industry and the **AG-362P** particularly developed for the cosmetics and glass industries.

The **AG-362** guns are available with two different design manifolds to allow you to choose the layout of air/fluid connection and method of gun attachment. The **AG-362L** lever operated version for fastest removal and the **AG-362S** screw attached version with multiple machine mounting options and smaller size.



DEVILBISS AG-360 SERIES

Typical coating types and applications

- Solvent and Water Based Paints and Materials
- Wood sector Stains, Sealers and Topcoats
- Adhesives and Glues
- Ceramics, Enamel and Glaze
- Epoxy Primers and Polyurethane Top coats
- Air drying, stoving and 2K coatings
- UV and radiation cured finishes

Typical Mounting

- Rotary & Carousel Machines
- Reciprocators & Tranverse equipment
- Robot & complex gun movers
- Fixed spray stations



Shown above
Part Number: AG361-TE40-085N



AG-361 Non-Manifold Gun

- Low Pressure Air Atomizing Spray gun for fine finishing and General Industrial applications.
- AG-361 series shares common Air Caps and fluid tips with the market leading DeVilbiss PRO Lite hand gun. This means the AG-361 range offer consistent application parameters between Automatic and Hand spray stations in the same facility
- Modular, easy to maintain gun construction
- High Grade Stainless Steel gun head and fluid passageways for use with all coating types
- Air Caps available in HVLP, Trans Tech/High Efficiency and CONVENTIONAL Air Atomization versions
- Total control of application parameters by means of independent Atomizing and Spray Pattern air plus an 18 'click' per revolution fluid needle control knob.

Evolve for your process with Accessories...

- Atomization Type
- Fluid Needle & Nozzle size
- Fluid Needle & Nozzle construction
- Local ATOM & FAN air control or Remote control
- 18 click/rev needle control or full needle opening with remote fluid control or Micrometer fluid control
- 90° Air cap indexing or free rotation
- Dead-head fluid feed or Recirculating.

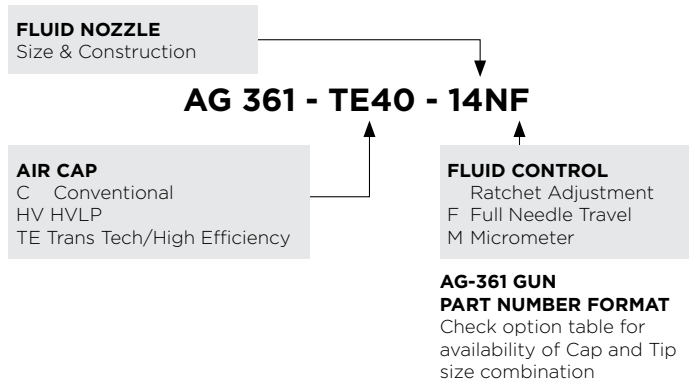

Air Cap and Fluid Nozzle Options AG-361 Gun

Air Cap	Atomization Type	0.85 mm	1.0 mm	1.2 mm	1.4 mm	1.6 mm	1.8 mm	2.0 mm	2.2 mm
C1	Conventional	S	S	S	S	S	S		
C2	Conventional	S	S	S	S	S	S		
C3	Conventional	S	S	S	S	S	S		

These Air Caps match with PROC-215-XX Fluid Nozzle where XX=orifice size

HV30	HVLP	S	SN	S	SN	S	SN	S	SN
HV40	HVLP	S	SN	S	SN	S	SN	S	SN
TE10	Trans Tech (High Efficiency)	S	SN	S	SN	S	SN	S	SN
TE20	Trans Tech (High Efficiency)	S	SN	S	SN	S	SN	S	SN
TE30	Trans Tech (High Efficiency)	S	SN	S	SN	S	SN	S	SN
TE40	Trans Tech (High Efficiency)	S	SN	S	SN	S	SN	S	SN
TE40R	Trans Tech (High Efficiency)	S	SN	S	SN	S	SN	S	SN

These Air Caps match with PRO-205-XX Fluid Nozzle where XX=orifice size

S = High Quality Stainless Steel Tips & Needles available in this type & size

N = Nitride Hardened Tips & Needles also available in this type & size

DEVILBISS AG-360 SERIES

Evolve...

Standard 18 click per revolution ratchet fluid needle adjusters for close-up local manual control are fitted to all AG-360 series guns as standard. Optional SPA-167-K unrestricted full needle travel end cap for remote fluid control using a fluid regulator available as an accessory.

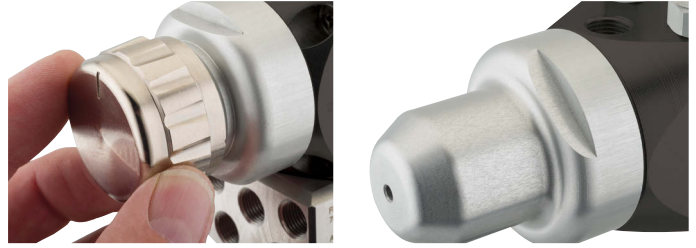

AG-361E Ceramic & Enamel Industry Gun

Gun shown AG361E-C62-28C



AG-361E Ceramic & Enamel Industry Version

A specialized version of the AG-361 for the application of Ceramic Glaze and Waterbased Enamels. The AG-361E has an extended range of specialist Air Caps and Fluid Nozzles capable of handling the high fluid flows and abrasive nature of the coating and environment.

- Completely new dedicated air cap range for the superior application of coatings onto sanitaryware, tableware and all ceramicware
- Stainless Steel, Hardened Stainless, Nitride Hardened and Tungsten Carbide version Fluid Nozzles & Needles for abrasive coatings
- Special O ring needle packing designed for waterbased abrasive particle coatings.

FLUID NOZZLE
Size & Construction

AG361E - C62 - 28CF

AIR CAP
C Conventional
HV HVLP
TE Trans Tech/High Efficiency

FLUID CONTROL
Ratchet Adjustment
F Full Needle Travel
M Micrometer

Air Cap and Fluid Nozzle Options AG-361E Gun

Air Cap	Atomization Type	1.4 mm	1.6 mm	1.8 mm	2.0 mm	2.2 mm	2.8 mm
C1	Conventional	S	S	S			
C2	Conventional	S	S	S			
C3	Conventional	S	S	S			

These Air Caps match with PROC-215-XX Fluid Nozzle where XX=orifice size

HV30	HVLP	SN	S	SN	S	SN	
HV40	HVLP	SN	S	SN	S	SN	
TE10	Trans Tech (High Efficiency)	SN	S	SN	S	SN	
TE20	Trans Tech (High Efficiency)	SN	S	SN	S	SN	
TE30	Trans Tech (High Efficiency)	SN	S	SN	S	SN	
TE40	Trans Tech (High Efficiency)	SN	S	SN	S	SN	
TE40R	Trans Tech (High Efficiency)	SN	S	SN	S	SN	

These Air Caps match with PRO-205-XX Fluid Nozzle where XX=orifice size

C62	Conventional						SNC
C64	Conventional					SNC	
C67	Conventional	SN		SNC			

These Air Caps match with PRO-250-XX Fluid Nozzle where XX=orifice size

S = High Quality Stainless Steel Tips & Needles available in this type & size
N = Nitride Hardened Tips & Needles also available in this type & size
C = Tungsten Carbide Tips and Needles also available in this type & size

AG-361E GUN PART NUMBER FORMAT
Check option table for availability of Cap and Tip size combination

DEVILBISS AG-360 SERIES

AG-362 Industrial Coating Gun

Built to the same superior specification as the AG-361 automatic guns but with the addition of a quick detachable manifold base. This allows the gun to be quickly and easily removed for maintenance, cleaning or change-over without disturbing the positional settings. On re-attaching the fluid and air can be turned back on and the gun is instantly in the right location ready for operation.

Two manifold versions are available:

- A lever operated cam version allowing very fast removal and replacement of the gun during the production process
- A low profile screw attached version which also has the pressure capability for mounting the A-363 Air Assisted Airless Automatic gun. Just swap gun, change pump and spray!

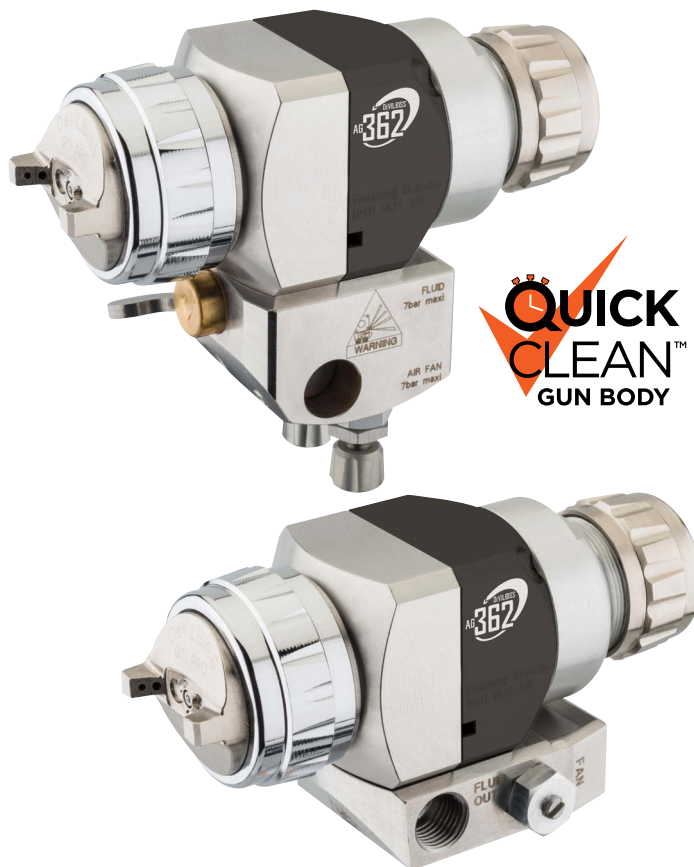

Shown above
 Right AG362-TE40-085N-S
 Left AG362-C3-14-L

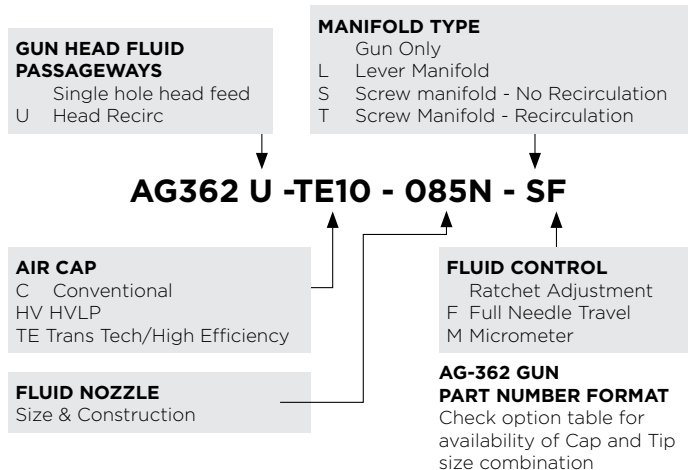

DEVILBISS AG-360 SERIES

AG-362 Removable Manifold Gun

- 1 Fluid Tip
- 2 Air Cap
- 3 Needle Packing
- 4 Main Piston
- 5 Fluid Control
- 6 Fluid Needle
- 7 Detachable Manifold
- 8 Air Valve (one of two fitted, low profile version shown)
- 9 Fluid Inlet

Section through AG362 Screw Manifold Gun

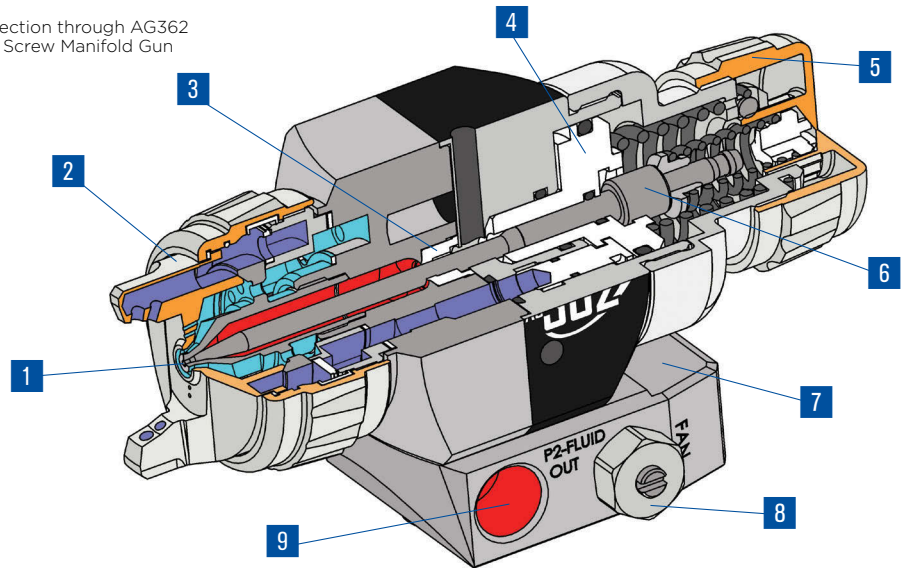

Evolve...

Screw air control valves for local control of fan and atomizing air pressures are fitted to all AG-360 series guns as standard. SPA-22 adaptors for connection to external, remote, air regulation and control available as an accessory.



Air Cap and Fluid Nozzle Options AG-362 Spray Gun

Air Cap	Atomization Type	0.85 mm	1.0 mm	1.2 mm	1.4 mm	1.6 mm	1.8 mm	2.0 mm	2.2 mm
C1	Conventional	S	S	S	S	S	S		
C2	Conventional	S	S	S	S	S	S		
C3	Conventional	S	S	S	S	S	S		

These Air Caps match with PROC-215-XX Fluid Nozzle where XX=orifice size

HV30	HVLP	S	SN	S	SN	S	SN	S	SN
HV40	HVLP	S	SN	S	SN	S	SN	S	SN
TE10	Trans Tech (High Efficiency)	S	SN	S	SN	S	SN	S	SN
TE20	Trans Tech (High Efficiency)	S	SN	S	SN	S	SN	S	SN
TE30	Trans Tech (High Efficiency)	S	SN	S	SN	S	SN	S	SN
TE40	Trans Tech (High Efficiency)	S	SN	S	SN	S	SN	S	SN
TE40R	Trans Tech (High Efficiency)	S	SN	S	SN	S	SN	S	SN

These Air Caps match with PRO-205-XX Fluid Nozzle where XX=orifice size

S = High Grade Stainless Steel available in this type and size
 N = Nitride Hardened Tips & Needles available in this type & size

Evolve...

Air Cap 360° swivel fitted to all AG-361 guns as standard. 90° Index Air Baffle to interact with Air Cap design giving positive 90° indexing and positioning available as an accessory.



AG-362P Petite Head Removable Manifold Gun



AG-362P 'Petite' small head version

A modified manifold mounted gun designed for the precision application of coatings onto cosmetics packaging and glassware. The gun utilizes 'Petite' precision air caps and fluid nozzles specifically designed for this style of application. For extra-fine fluid control the gun is fitted with a Micrometer vernier needle control knob assembly that allows ultra-fine precision fluid setting.

Evolve...

Precision Micrometer needle adjustment can be fitted as standard on all AG-361 and AG-362 guns. It is also available as an accessory.

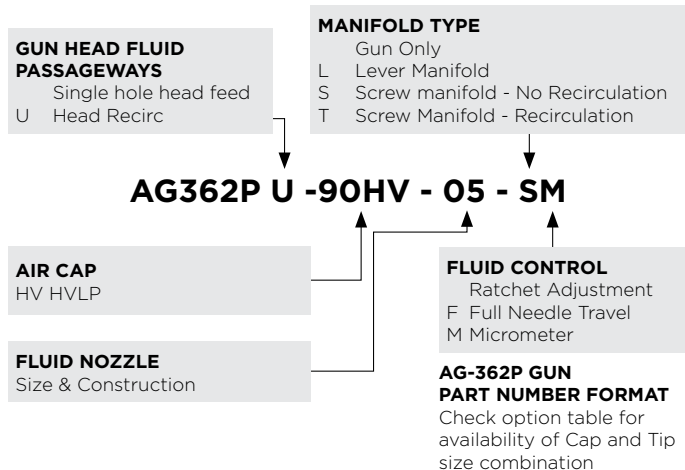

'Petite' front end with exceptional atomization and application capabilities.



Optional FFKM Manifold interface seals for compatibility with aggressive solvents eg Acetone & MEK, typically used in the glass and cosmetics industry.

Air Cap and Fluid Nozzle Options

AG-362P Air Cap	Atomization Type	H 0.5 mm	G 0.7 mm	FHV 1.0 mm
90HV	HVLP	S	S	S

These Air Caps match with CV-30-X Fluid Nozzle where X=orifice size code letter
 S = High Grade stainless steel Tips and Needles available in this type & size

AG-362 Manifold options and features

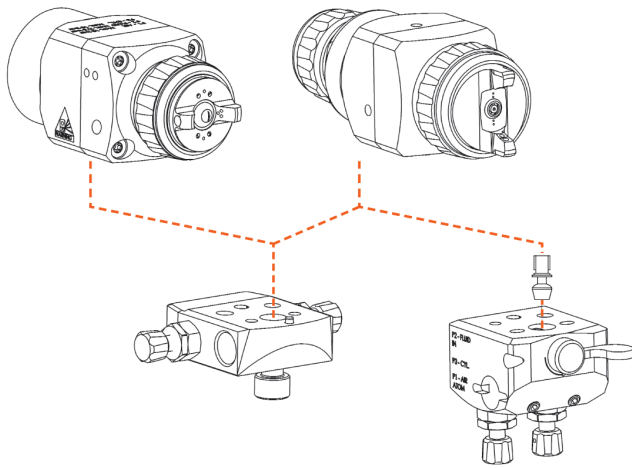

AG-362 Low Profile Screw manifold Mounting Options

Designed for multiple mounting options, this Manifold can be supplied with four different mounting fixtures (shown below). These fixtures are attached to the manifold surface using 2 x M5 and 2 x M4 threaded holes (exact locations available on request) which, in turn, may be used by the customer to attach the gun in any orientation and location required by the customer.

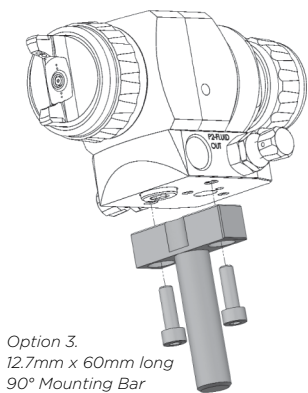

Option 3.
12.7mm x 60mm long
90° Mounting Bar

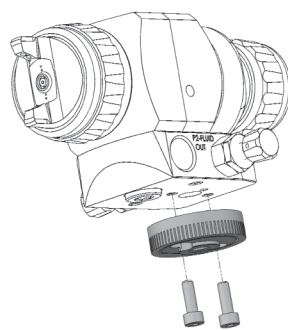

Option 4.
Machine mounting
graduated turret

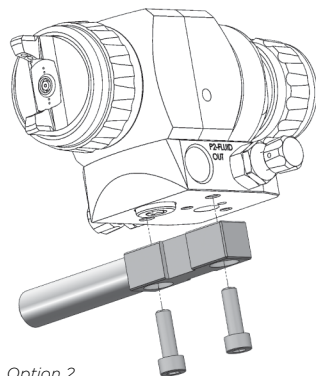

Option 2.
12.7mm x 60mm long
Mounting Bar

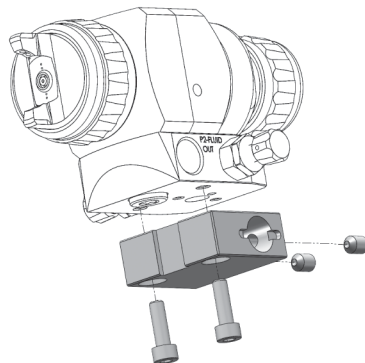

Option 1.
12.7mm Mounting hole

AG-362 Manifold options and features

Two manifold options exist for the **AG-362** variant guns – a lever operated version and a Low profile Screw version. The lever operated version gives the ability to remove the gun in the minimum time and utilizes a 12.7mm dia mounting hole. The Screw version provides a lower profile for restricted machine mounting spaces, and greater mounting versatility. However the low profile screw version also has the ability and pressure rating to directly mount the **AG-363** Air Assisted Airless Automatic gun. For high production rotatory and reciprocating machine users this feature allows increased flexibility and space saving to mount different guns for different coating types.



AG-362 Manifold Fluid Feed Options

Depending upon which manifold the gun is mounted on (Lever or Screw) fluid feed to the gun head can be by several different ways.

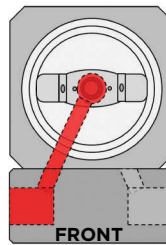

Option 4. Screw Manifold.
AG-362 Fluid Inlet Left.
Buy non-recirculating
Base version ready for this
format from DeVilbiss.

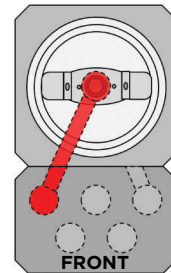

Option 5. Lever Manifold.
AG-362. Single fluid
input from left. Buy non
recirculating gun head
version from DeVilbiss.

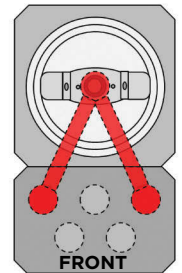

Option 6. Lever
Manifold. AG-362. Head
Recirculation. Buy
Recirculating gun head
version of gun from
DeVilbiss.

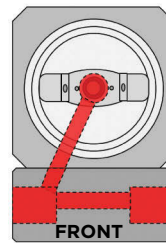

Option 1. Screw
Manifold. AG-362 Base
Recirculation. Fluid Entry
from Left or Right. Buy
recirculating Base version
ready for this format from
DeVilbiss.

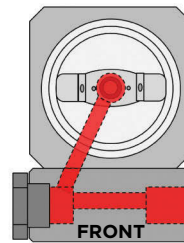

Option 2. Screw Manifold.
AG-362 Fluid Inlet Right.
Buy recirculating Base
version ready for this
format from DeVilbiss and
plug unwanted fluid inlet
with SPA-94.

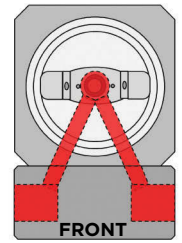

Option 3. Screw
Manifold. AG-362 Head
Recirculation. Buy
Recirculating gun head
version from DeVilbiss.

DEVILBISS AG-360 SERIES

Low Pressure Air Atomization Automatic Spray Gun Range



Spray Gun Specifications

Gun Dimensions & Weights	
AG-361 Size (L x H x W) mm	140 x 67 (inc valves) x 44
AG-361 Weight	668 g (inc air cap)
AG-362 Gun Size (L x H x W) mm	122 x 44 x 44
AG-362 (Gun only) Weight	557 g (inc air cap)
AG-362P Size (L x H x D) mm	145 x 44 x 44
AG-362P (Gun only) Weight	524 g (inc air cap)
Manifold Dimensions & Weights	
Cam Manifold Size (L x W x H) mm	60 x 44 x 53 (inc valves)
Cam Manifold Weight	347 g
Screw Manifold Size (L x W x H) mm	59 x 63 (inc valves) x 20
Screw Manifold Weight	268 g
All Guns	
Max Air Input Pressure (P1)	7 bar
Max Fluid Input Pressure (P2)	7 bar
Max Operating Ambient Temperature	40°C nominal
Gun Head & Fluid Passageways	Stainless Steel
Gun Body Material	QuickClean™ coated Aluminium
Manifold Material	Stainless Steel
Fluid Nozzle & Needle Materials	303 Stainless Steel, Nitride coated Stainless Steel, Tungsten carbide
Seals & O rings	HDPE, FEPM, PTFE, FFKM

Fluid & Air Inlets

AG-361 Industrial & Enamel Guns	
CYL Air inlet connection	1/8" G
Fluid Inlet connection	1/4" G
CAP Air Inlet connection	1/4" G
AG-362L Lever Manifold	
CYL Air inlet connection	1/8" G
Fluid Inlet connection	1/8" G
Fluid Outlet connection	1/8" G
ATOM Air inlet connection	1/8" G
FAN Air inlet connection	1/8" G
AG-362S Screw Manifold	
CYL Air inlet connection	1/8" G
Fluid Inlet connection	1/4" NPS
Fluid Outlet connection	1/4" NPS
CAP Air inlet (ATOM+FAN)	1/4" G

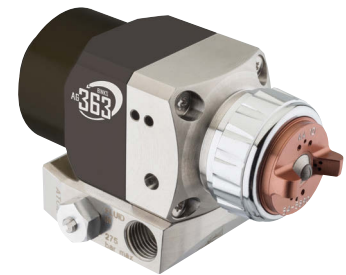

Completing the range – the AG-363 Air Assisted Airless Automatic spray gun. Invaluable for high speed, high efficiency spraying.

360 Series Air Cap Chart

Air Cap and Type	Air Consumption	Air Inlet Pressure Recommended	*Typical Fluid Flow	*Typical Fan Pattern Size
C1 Conventional	300 L/min (10.7 cfm)	3 Bar (45 psi)	150-250 ml/min	270 mm @ 200mm distance
C2 Conventional	290 L/min (10.3 cfm)	3 Bar (45 psi)	100-350 ml/min	250 mm @ 200mm distance
C3 Conventional	440 L/min (15.7 cfm)	3 Bar (45 psi)	250-600 ml/min	360 mm @ 200mm distance
TE10 Trans-Tech/High Efficiency	255 L/min (9.1 cfm)	2 Bar (30 psi)	150-200 ml/min	300 mm @ 200mm distance
TE20 Trans-Tech/High Efficiency	325 L/min (11.6 cfm)	2 Bar (30 psi)	150-200 ml/min	290 mm @ 200mm distance
TE30 Trans-Tech/High Efficiency	375 L/min (13.3 cfm)	2 Bar (30 psi)	200-300 ml/min	300 mm @ 200mm distance
TE40 Trans-Tech/High Efficiency	355 L/min (12.6 cfm)	2 Bar (30 psi)	250-400 ml/min	380 mm @ 200mm distance
TE50 Trans-Tech/High Efficiency	425 L/min (15.1 cfm)	2 Bar (30 psi)	250-400 ml/min	300 mm @ 200mm distance
HV30 HVLP	450 L/min (16.0 cfm)	1.10 Bar (26 psi)	160-200 ml/min	315 mm @ 200mm distance
HV40 HVLP	450 L/min (16.0 cfm)	1.75 Bar (16 psi)	160-200 ml/min	315 mm @ 200mm distance
C62 Conventional	431 L/min (15.4 cfm)	3 Bar (45 psi)	< 3.5 L/min	390 mm @ 300mm distance
C64 Conventional	400 L/min (14.3 cfm)	3 Bar (45 psi)	< 2.5 L/min	340 mm @ 300mm distance
C67 Conventional	426 L/min (15.2 cfm)	3 Bar (45 psi)	< 2.0 L/min	430 mm @ 300mm distance

Note: HV30 and HV40 (HVLP) operates at 0.7 bar (10 psi) at the cap. All illustrated flow rates may vary according to paint/material and pressures used.

For Further technical information refer to the DeVilbiss AG-361 and AG-362 Service Bulletins



SOLUTIONS FOR YOUR WORLD

www.carlisleleft.com

World Class Manufacturers of: | Process Controls | Curing & Conveying
Electrostatics | Fluid Handling | Powder Coating | Atomization

Carlisle Fluid Technologies US
16430 N. Scottsdale Road, Suite 450
Scottsdale, AZ 85254

Tel: 1-800-992-4657
Fax: 1-877-790-6965
Email: ghcustserv@carlisleleft.com